

MicroHAWK F320-F / F330-F / F420-F / F430-F Smart Camera

User Manual



NOTE

- All rights reserved.
- No part of this publication may be reproduced, stored in a retrieval system, or transmitted, in any form, or by any means, mechanical, electronic, photocopying, recording, or otherwise, without the prior written permission of OMRON.
- No patent liability is assumed with respect to the use of the information contained herein. Moreover, because OMRON is constantly striving to improve its high-quality products, the information contained in this manual is subject to change without notice. Every precaution has been taken in the preparation of this manual. Nevertheless, OMRON assumes no responsibility for errors or omissions.

Neither is any liability assumed for damages resulting from the use of the information contained in this publication.

Trademarks

- Sysmac and SYSMAC are trademarks or registered trademarks of OMRON Corporation in Japan and other countries for OMRON factory automation products.
- Microsoft, Windows, Windows Vista, Excel, and Visual Basic are either registered trademarks or trademarks of Microsoft Corporation in the United States and other countries.
- ODVA, CIP, CompoNet, DeviceNet, and EtherNet/IP are trademarks of ODVA.
- QR Code is a registered trademark of DENSO WAVE INCORPORATED.

Other company names and product names in this document are the trademarks or registered trademarks of their respective companies.

Copyrights

Microsoft product screen shots reprinted with permission from Microsoft Corporation.

Terms and Conditions Agreement

Warranty, Limitations of Liability

Warranties

- **Exclusive Warranty**

Omron's exclusive warranty is that the Products will be free from defects in materials and workmanship for a period of twelve months from the date of sale by Omron (or such other period expressed in writing by Omron). Omron disclaims all other warranties, express or implied.

- **Limitations**

OMRON MAKES NO WARRANTY OR REPRESENTATION, EXPRESS OR IMPLIED, ABOUT NON-INFRINGEMENT, MERCHANTABILITY OR FITNESS FOR A PARTICULAR PURPOSE OF THE PRODUCTS. BUYER ACKNOWLEDGES THAT IT ALONE HAS DETERMINED THAT THE PRODUCTS WILL SUITABLY MEET THE REQUIREMENTS OF THEIR INTENDED USE.

Omron further disclaims all warranties and responsibility of any type for claims or expenses based on infringement by the Products or otherwise of any intellectual property right.

- **Buyer Remedy**

Omron's sole obligation hereunder shall be, at Omron's election, to (i) replace (in the form originally shipped with Buyer responsible for labor charges for removal or replacement thereof) the non-complying Product, (ii) repair the non-complying Product, or (iii) repay or credit Buyer an amount equal to the purchase price of the non-complying Product; provided that in no event shall Omron be responsible for warranty, repair, indemnity or any other claims or expenses regarding the Products unless Omron's analysis confirms that the Products were properly handled, stored, installed and maintained and not subject to contamination, abuse, misuse or inappropriate modification. Return of any Products by Buyer must be approved in writing by Omron before shipment. Omron Companies shall not be liable for the suitability or unsuitability or the results from the use of Products in combination with any electrical or electronic components, circuits, system assemblies or any other materials or substances or environments. Any advice, recommendations or information given orally or in writing, are not to be construed as an amendment or addition to the above warranty.

See <http://www.omron.com> or contact your Omron representative for further information.

Limitation on Liability; Etc

OMRON COMPANIES SHALL NOT BE LIABLE FOR SPECIAL, INDIRECT, INCIDENTAL, OR CONSEQUENTIAL DAMAGES, LOSS OF PROFITS OR PRODUCTION OR COMMERCIAL LOSS IN ANY WAY CONNECTED WITH THE PRODUCTS, WHETHER SUCH CLAIM IS BASED IN CONTRACT, WARRANTY, NEGLIGENCE OR STRICT LIABILITY.

Further, in no event shall liability of Omron Companies exceed the individual price of the Product on which liability is asserted.

Application Considerations

Suitability of Use

Omron Companies shall not be responsible for conformity with any standards, codes or regulations which apply to the combination of the Product in the Buyer's application or use of the Product. At Buyer's request, Omron will provide applicable third party certification documents identifying ratings and limitations of use which apply to the Product. This information by itself is not sufficient for a complete determination of the suitability of the Product in combination with the end product, machine, system, or other application or use. Buyer shall be solely responsible for determining appropriateness of the particular Product with respect to Buyer's application, product or system. Buyer shall take application responsibility in all cases.

NEVER USE THE PRODUCT FOR AN APPLICATION INVOLVING SERIOUS RISK TO LIFE OR PROPERTY WITHOUT ENSURING THAT THE SYSTEM AS A WHOLE HAS BEEN DESIGNED TO ADDRESS THE RISKS, AND THAT THE OMRON PRODUCT(S) IS PROPERLY RATED AND INSTALLED FOR THE INTENDED USE WITHIN THE OVERALL EQUIPMENT OR SYSTEM.

Programmable Products

Omron Companies shall not be responsible for the user's programming of a programmable Product, or any consequence thereof.

Disclaimers

Performance Data

Data presented in Omron Company websites, catalogs and other materials is provided as a guide for the user in determining suitability and does not constitute a warranty. It may represent the result of Omron's test conditions, and the user must correlate it to actual application requirements. Actual performance is subject to the Omron's Warranty and Limitations of Liability.

Change in Specifications

Product specifications and accessories may be changed at any time based on improvements and other reasons. It is our practice to change part numbers when published ratings or features are changed, or when significant construction changes are made. However, some specifications of the Product may be changed without any notice. When in doubt, special part numbers may be assigned to fix or establish key specifications for your application. Please consult with your Omron's representative at any time to confirm actual specifications of purchased Product.

Errors and Omissions

Information presented by Omron Companies has been checked and is believed to be accurate; however, no responsibility is assumed for clerical, typographical or proofreading errors or omissions.

Safety Precautions

- **Symbols and the meanings for safety precautions described in this manual.**

In order for the product to be used safely, the following indications are used in this book to draw your attention to the cautions. The cautions with the indications describe the important contents for safety.



WARNING





Indicates a potentially hazardous situation which, if not avoided, will result in minor or moderate injury, or may result in serious injury or death. Additionally there may be significant property damage.



CAUTION







Indicates a potentially hazardous situation which, if not avoided, may result in minor or moderate injury or in property damage.

- **Meanings of Alert Symbols**

	<p>General Prohibition</p> <p>Indicates general prohibitions, including warnings, for which there is no specific symbol.</p>
	<p>General Caution</p> <p>Indicates general cautions, including warnings, for which there is no specific symbol.</p>
	<p>Electrical Hazard</p> <p>Indicates the possible danger of electric shock under specific conditions.</p>
	<p>High Temperature Caution</p> <p>Indicates the possible danger of injury by high temperature under specific conditions.</p>

● Alert statements in this Manual

 **WARNING**

<p>This product must be used according to this manual or Instruction sheet. Failure to observe this may result in impairment of functions and performance of the product.</p>	
<p>This product is not designed or rated for ensuring safety of persons. Do not use it for such purposes.</p>	
<p>Never connect the AC power supply with this product. When the AC power supply is connected, it causes the electric shock and a fire.</p>	
<p>When using equipment that is connected to an AC power source such as an AC adapter or PoE injector, use it within the rated voltage range. Usage with a voltage higher than what it is rated for may cause serious personal injury due to electric shock, or serious physical damage due to fire or equipment failure. Do not touch any part of the device while in operation, or immediately after turning OFF the power.</p>	
<p>Since camera that can be connected with this product emits a visible light that may have an adverse effect on the eyes, do not stare directly into the light emitted from the LED. If a specular object is used, take care not to allow reflected light enter your eyes.</p>	
<p>Please take external safety measures so that the system as a whole should be on the safe side even if a failure of a this product or an error due to an external factor occurred. An abnormal operation may result in serious accident.</p>	
<p>Please take fail-safe measures on your side in preparation for an abnormal signal due to signal conductor disconnection and/or momentary power interruption. An abnormal operation may result in a serious accident.</p>	

 **CAUTION**

<p>Danger of burns. Do not touch the case while the camera is running or just after power is turned OFF, since it remains extremely hot.</p>	
--	---

Precautions for Safe Use

Condition of the fitness of OMRON products

- Please do not use this product to directly or indirectly use to detect the human body for the purpose of ensuring the safety. In the same application, please use the safety sensor that is published on our sensor catalog.
- Omron products are designed and manufactured as general-purpose products for use in general industrial applications. They are not intended to be used in the following critical applications. If you are using Omron products in the following applications, Omron shall not provide any warranty for such Omron products, unless otherwise specifically agreed or unless the specific applications are intended by Omron.
 - (a) Applications with stringent safety requirements, including but not limited to nuclear power control equipment, combustion equipment, aerospace equipment, railway equipment, elevator/lift equipment, amusement park equipment, medical equipment, safety devices and other applications that could cause danger/harm to people's body and life
 - (b) Applications that require high reliability, including but not limited to supply systems for gas, water and electricity, etc., 24 hour continuous operating systems, financial settlement systems and other applications that handle rights and property
 - (c) Applications under severe condition or in severe environment, including but not limited to outdoor equipment, equipment exposed to chemical contamination, equipment exposed to electromagnetic interference and equipment exposed to vibration and shocks
 - (d) Applications under conditions and environment not described in specifications
- *1. In addition to the applications listed from (a) to (d) above, Omron products (see definition) are not intended for use in vehicles designed human transport (including two wheel vehicles). Please do NOT use Omron products for vehicles designed human transport. Please contact the Omron sales staff for information on our automotive line of products.
- *2. The above is part of the Terms and Conditions Agreement. Please use carefully read the contents of the guarantee and disclaimers described in our latest version of the catalog, data sheets and manuals.

Installation Environment

- Do not use the product in areas where flammable or explosive gases are present.
- Be careful when unpacking this product, please. Injury may occur if the camera falls and strikes a person.
- Do not install the product close to high-voltage devices and power devices in order to secure the safety of operation and maintenance.
- Make sure to tighten all installation screws securely.

Power Supply and Wiring

- Make sure to use the product with the power supply voltage specified by this manual.
- Do not connect AC power source to Sensor Controller. If connects AC power source, it might be a cause of the failure.
- Use the wire of a suitable size (AWG 16 to 12) according to the current consumption.
- Use a DC power supply with safety measures against high-voltage spikes (safety extra low-voltage circuits on the secondary side).
- Keep the power supply wires as short as possible.
- Do the following confirmations again before turning on the power supply.
 - Is the voltage and polarity of the power supply correct?
 - Is not the load of the output signal short-circuited?
 - Is the load current of the output signal appropriate?
 - Is not the mistake found in wiring?

Ground

- Check wiring again before turning on the camera.

Other

- Use only the cables designed specifically for the camera. Use of other products may result in malfunction or damage of the camera.
- Always turn OFF the power of the camera and peripheral devices before connecting or disconnecting a cable. Connecting the cable with power supplied may result in damage of the camera or peripheral devices.
- Do not apply torsion stress to the cable. It may damage the cable.
- Secure the minimum bending radius of the cable. Otherwise the cable may be damaged.
- Do not attempt to dismantle, repair, or modify the product.
- Should you notice any abnormalities, immediately stop use, turn OFF the power supply, and contact your OMRON representative.
- While the power is ON or immediately after the power is turned OFF, the case are still hot. Do not touch the case.
- The camera must be used with the special mounting bracket (-AM0 or -AM1: sold separately), or the camera may generate heat.
- When disposing of the product, treat it as an industrial waste.
- Do not drop the product nor apply excessive vibration or shock to the product. Doing so may cause malfunction or burning.

When controlling stages and robots using the read results (axis movement output based on calibration and alignment measurement), always take fail-safe measures within the stage and robot systems, such as checking whether the data obtained from the read results is within the range of movement of the stages and robots.

Precautions for Correct Use

Installation and Storage Sites

Install and store the product in a location that meets the following conditions:

- Surrounding temperature of 0 to +40°C (-50 to +75°C in storage)
- No rapid changes in temperature (place where dew does not form)
- Relative humidity of between 5 to 85%
- No presence of corrosive or flammable gases
- Place free of dust, salts and iron particles
- Place free of vibration and shock
- Place out of direct sunlight
- Place where it will not come into contact with water, oils or chemicals
- Place not affected by strong electro-magnetic waves
- Place not near to high-voltage, or high-power equipment

Ambient Temperature

- For good heat dissipation, keep the distance.
- Do not install the product immediately above significant heat sources, such as heaters, transformers, or large-capacity resistors.
- Do not let the ambient temperature exceed an operating temperature range.
- Provide a forced-air fan cooling or air conditioning if the ambient temperature is near the upper range of operating temperature range so that the ambient temperature never exceeds the upper range of operating temperature range.

Noise Resistance

- Do not install the product in a cabinet containing high-voltage equipment.
- Do not install the camera within 200 mm of power cables.

Component Installation and Handling

- Turning OFF the Power
When a message is displayed indicating that a task is in progress, do not turn OFF the power. Doing so causes the data in the memory to be corrupted, resulting in the product not operating properly upon the next start-up.
When turns OFF, conform the followings proceedings have completed. and then operate again.
 - When saves using the camera:
Confirm the save processing is completed and next operation is possible.
 - When saves using communication command:
Intended command is completed.
- Setting of Power Source
The power source need to be supplied from DC power source apparatus which is taken a save ultra-low voltage circuit: to protect high voltage.

Maintenance

- Turn OFF the power and ensure the safety before maintenance.
- Clean the lens with a lens-cleaning cloth or air brush.
- Lightly wipe off dirt with a soft cloth.
- Do not use thinners or benzene.
- To ensure safe access for operation and maintenance, separate the camera as much as possible from high-voltage equipment and power machinery.

Communication with High-order Device

- After confirming that this product is started up, communicate with the high-order device. When this product has started up, an indefinite signal may be output from the high-order interface. To avoid this problem, clear the receiving buffer of your device at initial operations.

Other

- For symbols with a highly gloss surface, reading errors may occur because of regular reflection of the LED light. If this occurs, provide a skew angle of 15° against the symbol.
- Do not look into the light emitted from the LED directly. When this products has started up, the LED flashes.
- Under an environment with high humidity and rapid changes in temperature, the inside of the front plate might fog up. When the read rates lower due to the fog, leave the device with turned it on for 30 minutes to 2 hours. Use it again after checking there is no fog on the front plate.

LED Safety

- This product is classified into the IEC 62471-1:2006 Risk-Exempt Group. However, this product does emit a strong visible light that may have an adverse effect on the eyes. Do not stare directly into the light emitted from the LED. If a specular object is used, take care not to allow reflected light to enter your eyes.

Regulations and Standards

Using Product Outside Japan

This regulation applies to MicroHAWK cameras and peripheral devices.

If you export (or provide a non-resident with) this product or a part of this product that falls under the category of goods (or technologies) specified by the Foreign Exchange and Foreign Trade Control Law as those which require permission or approval for export, you must obtain permission or approval or service transaction permission) pursuant to the law.

Conformance to EC/EU Directives

This regulation applies to MicroHAWK smart cameras and peripheral devices.

- This product is in compliance with all applicable directives, 2014/30/EU, 2014/35/EU, and 2011/65/EU.
- This product complies with EC/EU Directives. EMC-related performance of the OMRON devices that comply with EC/EU Directives will vary depending on the configuration, wiring, and other conditions of the equipment or control panel on which the OMRON devices are installed.
- The customer must, therefore, perform the final check to confirm that devices and the overall machine conform to EMC standards.

Conformance to UL Standards

This regulation applies to MicroHAWK cameras and peripheral devices.

This product complies with UL Standards.

- UL60950-1 2nd-edition, 2014 (Class III)

Korean Radio Regulation (KC)

사용자안내문

이 기기는 업무용 환경에서 사용할 목적으로 적합성평가를 받은 기기로서 가정용 환경에서 사용하는 경우 전파간섭의 우려가 있습니다.

Guide for Users

This equipment has been evaluated for conformity in a commercial environment. When used in a residential environment, it may cause radio interference.

Radio Frequency Interference Requirements: FCC



This equipment has been tested for compliance with FCC (Federal Communications Commission) requirements and has been found to conform to applicable FCC standards. To comply with FCC RF exposure compliance requirements, this device must not be co-located with or operate in conjunction with any other antenna or transmitter. Changes or modifications not expressly approved by the party responsible for compliance could void the user's authority to operate the equipment.

Model F420-F Class A Statement

NOTE: This equipment has been tested and found to comply with the limits for a Class A digital device, pursuant to part 15 of the FCC Rules. These limits are designed to provide reasonable protection against harmful interference when the equipment is operated in a commercial environment. This equipment generates, uses, and can radiate radio frequency energy and, if not installed and used in accordance with the instruction manual, may cause harmful interference to radio communications. Operation of this equipment in a residential area is likely to cause harmful interference in which case the user will be required to correct the interference at his own expense.

Models F320-F, F330-F, and F430-F Class B Statement

NOTE: This equipment has been tested and found to comply with the limits for a Class B digital device, pursuant to part 15 of the FCC Rules. These limits are designed to provide reasonable protection against harmful interference in a residential installation. This equipment generates, uses and can radiate radio frequency energy and, if not installed and used in accordance with the instructions, may cause harmful interference to radio communications. However, there is no guarantee that interference will not occur in a particular installation. If this equipment does cause harmful interference to radio or television reception, which can be determined by turning the equipment off and on, the user is encouraged to try to correct the interference by one or more of the following measures:

- Reorient or relocate the receiving antenna.
- Increase the separation between the equipment and receiver.
- Connect the equipment into an outlet on a circuit different from that to which the receiver is connected.
- Consult the dealer or an experienced radio/TV technician for help.

Radio Frequency Interference Requirements: Canada

This device complies with Industry Canada ICES-003. Operation is subject to the following two conditions: (1) This device may not cause harmful interference, and (2) this device must accept any interference received, including interference that may cause undesired operation. Cet appareil est conforme à la norme ICES-003 d'Industrie Canada. Son fonctionnement est soumis aux deux conditions suivantes: (1) l'appareil ne doit pas produire de brouillage, et (2) l'utilisateur de l'appareil doit accepter tout brouillage radioélectrique subi, même si le brouillage est susceptible d'en compromettre le fonctionnement.

Model F420-F : This Class A digital apparatus complies with Canadian ICES-003.

Cet appareil numérique de la classe A est conforme à la norme NMB-003 du Canada.

Models F320-F, F330-F and F430-F : This Class B digital apparatus complies with Canadian ICES-003. Cet appareil numérique de la classe B est conforme à la norme NMB-003 du Canada.

Revision History

The manual's part number and revision appear on the first and last pages.

Man.No.	Z433-E-04
----------------	------------------

↑
Revision

Revision	Date	Revised Content
01	November 2019	First publication.
02	January 2020	Updated front window, diffuser, and polarizer accessory part numbers.
03	May 2020	General improvements.
04	December 2020	General improvements.

Table of Contents

Terms and Conditions Agreement	3
Safety Precautions	5
Precautions for Safe Use	7
Precautions for Correct Use.....	9
Regulations and Standards	11
Revision History	13

Section 1 Introduction

1-1 Product Summary.....	1-2
1-2 Features and Benefits	1-3
1-3 Applications	1-4
1-4 Package Contents	1-5
1-5 MicroHAWK Smart Camera Models	1-6
1-6 Part Number Structure.....	1-8

Section 2 System Components

2-1 Label Information	2-2
2-2 Camera Dimensions	2-3
2-3 Accessories	2-10
2-4 Hardware Configurations.....	2-24
2-5 Mounting the Camera	2-28
2-6 I/O Wiring.....	2-29
2-7 Grounding and Power.....	2-37
2-8 I/O Filtering and Debounce	2-39
2-9 Camera Definition File Example	2-40
2-10 Status Indicators	2-41

Section 3 Getting Started with AutoVISION

3-1 Setting Up a Job in AutoVISION	3-2
--	-----

Section 4 Optics and Lighting

4-1 Optics.....	4-2
4-2 MicroHAWK Illumination	4-4

4-3	Machine Vision Lighting Principles	4-5
4-4	MicroHAWK F430-F External Illumination Control and Wiring.....	4-6

Appendices

A	Connector Pinouts	A-1
B	Cable Specifications	B-1
C	General Specifications	C-1
D	Serial Commands	D-1
E	USB Power Management (MicroHAWK F420-F).....	E-1
F	TCP/UDP and General Port Usage.....	F-1
G	Optics and Lighting Accessory Kit Installation.....	G-1

Introduction

This section provides a product summary as well as an overview of features, applications, package contents, smart camera models, part number structure, and ordering information.

1-1 Product Summary	1-2
1-2 Features and Benefits	1-3
1-3 Applications	1-4
1-4 Package Contents	1-5
1-5 MicroHAWK F320-F, F330-F, F420-F, and F430-F Smart Camera Models	1-6
1-6 Part Number Structure	1-8

1-1 Product Summary

MicroHAWK F320-F, F330-F, F420-F and F430-F Smart Cameras are designed for reliable vision performance in identification and inspection applications. As the world's smallest fully-integrated vision system, the compact size and wide variety of optics and illumination options of these cameras provide the best performance available for virtually any machine vision application.

MicroHAWK F320-F, F330-F, F420-F and F430-F allow automation engineers to implement inspection, color matching, symbol decoding, OCR, and more, in a single compact solution. The small form factor of these cameras allows flexible positioning in tight spaces.

AutoVISION software, designed for use with the MicroHAWK F320-F, F330-F, F420-F and F430-F, provides an intuitive interface, step-by-step configuration, and a library of presets that allow easy setup and deployment. For more complex vision applications, the system can be upgraded from AutoVISION to Visionscape.

1-2 Features and Benefits

- Simple Configuration of All Models with AutoVISION
- 5 Megapixel Color Sensor Available for All Models
- Smallest Camera in Class – All Models
- IP40 Enclosure (F320-F, F330-F)
- IP54 Enclosure (F420-F)
- IP65 / IP67 Enclosure (F430-F)
- Corner-Exit Cable (F420-F)
- Autofocus Available (F420-F, F430-F)
- Power over Ethernet (F330-F)
- RS-232 (MicroHAWK F320-F, F420-F, F430-F)
- USB 2.0 Full-Speed (F320-F)
- USB 2.0 High-Speed (F420-F)
- Ethernet over USB/HID (F320-F, F420-F)
- Ethernet TCP/IP (F330-F, F430-F)
- EtherNet/IP (F430-F)
- Single Locking RJ50 Connector and Cable (F320-F)
- Single Locking RJ45 Connector and Cable (F330-F)
- Ring Light Illumination Available (F430-F)

1-3 Applications

- Inspection
- Guidance
- Gauging
- Part presence/absence
- Color detection and matching
- Medical device inspection
- Fiducial location
- Part location/orientation detection
- Packaging
- Robotics
- Auto ID (Data Matrix and other 2D symbologies, 1D, OCR)
- 1D and 2D Code Verification
- OCV (Optical Character Verification)

1-4 Package Contents

Before you install AutoVISION software and connect your MicroHAWK F320-F, F330-F, F420-F or F430-F, please take a moment to confirm that the following items are available or accessible:

- A MicroHAWK F320-F, F330-F, F420-F or F430-F Smart Camera.
- An active internet connection to download the latest AutoVISION software installer from the Download Center on your region's Omron website.
- The cables or other accessories you have added to your order.

1-5 MicroHAWK F320-F, F330-F, F420-F and F430-F Smart Camera Models

MicroHAWK F320-F

Simple configuration with AutoVISION.
5 megapixel sensor available.
Smallest in class.
IP40 enclosure.
Single locking RJ50 connector and cable.
RS-232, Ethernet via USB.



MicroHAWK F330-F

Simple configuration with AutoVISION.
5 megapixel sensor available.
Smallest in class.
IP40 enclosure.
Single locking RJ45 connector and cable.
Ethernet TCP/IP.
Power over Ethernet.



MicroHAWK F420-F

Simple configuration with AutoVISION.
5 megapixel sensor available.
Autofocus available.
Smallest in class.
IP54 enclosure.
Corner-exit cable.
Serial RS-232, USB, or Ethernet over USB.



MicroHAWK F430-F

Simple configuration with AutoVISION.
5 megapixel sensor available.
Autofocus available.
Smallest in class.
IP65 / IP67 enclosure.
RS-232, Ethernet TCP/IP, EtherNet/IP.
Ring Light illumination available.



1-5-1 Software Options

AutoVISION Software provides a simple setup and runtime interface for solving basic to mid-range vision and auto ID challenges. Scalable with Visionscape Software.

Visionscape Software provides a professional setup and runtime interface with access to Omron Microscan's full auto ID, verification, and machine vision tools.

1-5-2 Feature Comparison

<i>Features</i>	<i>F320-F</i>	<i>F330-F</i>	<i>F420-F</i>	<i>F430-F</i>
Barcode Reading (1D/2D)	•	•	•	•
Complete Machine Vision Tool Set	•	•	•	•
Enclosure	IP40	IP40	IP54	IP65 / 67
Ethernet TCP/IP		•		•
EtherNet/IP				•
Ethernet over USB	•		•	
Serial (RS-232)	•		•	•
USB 2.0 High Speed / HID	•		•	
Power over Ethernet (PoE)		•		
Outer Illumination			•	•
Liquid Lens Autofocus			•	•
Color Sensor	•	•	•	•
AutoVISION Sensor (Vision Tools Only)	•	•	•	•
AutoVISION (Vision, Code Reading, and Verification)	•	•	•	•
Visionscape (Full Tool Set)	•	•	•	•

1-6 Part Number Structure

F320-F Part Number Structure

Use this legend when defining product part numbers. Please note that not all combinations of parameters are valid. For instance, fixed focus distance of 50 mm is not available with Narrow Lens. When ordering, use valid part numbers from the tables in the Ordering Information section only.

F320-F[XXX][Y][ZZZ]-NN[P]

Key	Classification	Code	Meaning
XXX	Focus Distance (mm)	050	Fixed Focus at 50 mm
		064	Fixed Focus at 64 mm
		081	Fixed Focus at 81 mm
		102	Fixed Focus at 102 mm
		133	Fixed Focus at 133 mm
		190	Fixed Focus at 190 mm
		300	Fixed Focus at 300 mm
Y	Lens	W	Wide Field of View - 5.2 mm Focal Length Lens
		M	Medium Field of View – 7.7 mm Focal Length Lens
		N	Narrow Field of View – 16 mm Focal Length Lens
ZZZ	Sensor	03M	752 x 480 (0.3 MP) Pixel, Mono Sensor, Global Shutter
		12M	1280 x 960 (1.2 MP) Pixel, Mono Sensor, Global Shutter
		50C	2592 x 1944 (5 MP) Pixel, Color Sensor, Rolling Shutter
L	Light Type	N	No Outer Light
C	Light Color	N	No Outer Light
P	Software License	S	AutoVISION Sensor (Vision Toolset Only)
		A	AutoVISION (Vision and Code Reading / Verification Toolsets)
		V	Visionscape (Full AutoVISION and Visionscape Toolsets)

Example Part Number:

- F320-F050W50C-NNV: Fixed Focus at 50 mm, Wide Lens, 5 MP Color, No Light, Visionscape (Full AutoVISION and Visionscape Toolsets)

F320-F Valid Product Matrix

Model	Category	Focus Type	Sensor	Lens	Focus Distance (mm)	Light	License
F320-F	Monochrome	Fixed Focus	03M, 12M	W, M	50, 64, 81, 102, 133, 190, 300	None	S, A, V
	Color	Fixed Focus	50C	W, M	50, 64, 81, 102, 133, 190, 300	None	S, A, V
	Monochrome	Fixed Focus	03M, 12M	N	64, 81, 102, 133, 190, 300	None	S, A, V
	Color	Fixed Focus	50C	N	64, 81, 102, 133, 190, 300	None	S, A, V

F320-F Ordering Information

Categories:

1. Fixed Focus Cameras

- a) F320-F Monochrome and Color Fixed Focus Camera with Standard Lens
- b) F320-F Monochrome and Color Fixed Focus Camera with Narrow Lens

1a) F320-F Mono and Color Camera with Standard Lens: Valid Combinations

F320-F[XXX][Y][ZZZ]-NN[P]

Key	Classification	Code	Meaning
XXX	Focus Distance (mm)	050	Fixed Focus at 50 mm
		064	Fixed Focus at 64 mm
		081	Fixed Focus at 81 mm
		102	Fixed Focus at 102 mm
		133	Fixed Focus at 133 mm
		190	Fixed Focus at 190 mm
		300	Fixed Focus at 300 mm
Y	Lens	W	Wide Field of View - 5.2 mm Focal Length Lens
		M	Medium Field of View – 7.7 mm Focal Length Lens
ZZZ	Sensor	03M	752 x 480 (0.3 MP) Pixel, Mono Sensor, Global Shutter
		12M	1280 x 960 (1.2 MP) Pixel, Mono Sensor, Global Shutter
		50C	2592 x 1944 (5 MP) Pixel, Color Sensor, Rolling Shutter
P	Software License	S	AutoVISION Sensor (Vision Toolset Only)
		A	AutoVISION (Vision and Code Reading / Verification Toolsets)
		V	Visionscape (Full AutoVISION and Visionscape Toolsets)

1b) F320-F Mono and Color Camera with Narrow Lens: Valid Combinations

Note: 50 mm Fixed Focus option not available with Narrow Lens.

F320-F[XXX]N[ZZZ]-NN[P]

Key	Classification	Code	Meaning
XXX	Focus Distance (mm)	064	Fixed Focus at 64 mm
		081	Fixed Focus at 81 mm
		102	Fixed Focus at 102 mm
		133	Fixed Focus at 133 mm
		190	Fixed Focus at 190 mm
		300	Fixed Focus at 300 mm
		ZZZ	Sensor
12M	1280 x 960 (1.2 MP) Pixel, Mono Sensor, Global Shutter		
50C	2592 x 1944 (5 MP) Pixel, Color Sensor, Rolling Shutter		
P	Software License	S	AutoVISION Sensor (Vision Toolset Only)
		A	AutoVISION (Vision and Code Reading / Verification Toolsets)
		V	Visionscape (Full AutoVISION and Visionscape Toolsets)

F330-F Part Number Structure

Use this legend when defining product part numbers. Please note that not all combinations of parameters are valid. For instance, fixed focus distance of 50 mm is not available with Narrow Lens. When ordering, use valid part numbers from the tables in the Ordering Information section only.

F330-F[XXX][Y][ZZZ]-NN[P]

Key	Classification	Code	Meaning
XXX	Focus Distance (mm)	050	Fixed Focus at 50 mm
		064	Fixed Focus at 64 mm
		081	Fixed Focus at 81 mm
		102	Fixed Focus at 102 mm
		133	Fixed Focus at 133 mm
		190	Fixed Focus at 190 mm
		300	Fixed Focus at 300 mm
Y	Lens	W	Wide Field of View - 5.2 mm Focal Length Lens
		M	Medium Field of View – 7.7 mm Focal Length Lens
		N	Narrow Field of View – 16 mm Focal Length Lens
ZZZ	Sensor	03M	752 x 480 (0.3 MP) Pixel, Mono Sensor, Global Shutter
		12M	1280 x 960 (1.2 MP) Pixel, Mono Sensor, Global Shutter
		50C	2592 x 1944 (5 MP) Pixel, Color Sensor, Rolling Shutter
L	Light Type	N	No Outer Light
C	Light Color	N	No Outer Light
P	Software License	S	AutoVISION Sensor (Vision Toolset Only)
		A	AutoVISION (Vision and Code Reading / Verification Toolsets)
		V	Visionscape (Full AutoVISION and Visionscape Toolsets)

Example Part Number:

- F330-F064W50C-NNV: Fixed Focus at 64 mm, Wide Lens, 5 MP Color – No Light, Visionscape (Full AutoVISION and Visionscape Toolsets)

F330-F Valid Product Matrix

Model	Category	Focus Type	Sensor	Lens	Focus Distance (mm)	Light	License
F330-F	Monochrome	Fixed Focus	03M, 12M	W, M	50, 64, 81, 102, 133, 190, 300	None	S, A, V
	Color	Fixed Focus	50C	W, M	50, 64, 81, 102, 133, 190, 300	None	S, A, V
	Monochrome	Fixed Focus	03M, 12M	N	64, 81, 102, 133, 190, 300	None	S, A, V
	Color	Fixed Focus	50C	N	64, 81, 102, 133, 190, 300	None	S, A, V

F330-F Ordering Information

Categories:

1. Fixed Focus Cameras

- a) F330-F Monochrome and Color Fixed Focus Camera with Standard Lens
- b) F330-F Monochrome and Color Fixed Focus Camera with Narrow Lens

1a) F330-F Mono and Color Camera with Standard Lens: Valid Combinations

F330-F[XXX][Y][ZZZ]-NN[P]

Key	Classification	Code	Meaning
XXX	Focus Distance (mm)	050	Fixed Focus at 50 mm
		064	Fixed Focus at 64 mm
		081	Fixed Focus at 81 mm
		102	Fixed Focus at 102 mm
		133	Fixed Focus at 133 mm
		190	Fixed Focus at 190 mm
		300	Fixed Focus at 300 mm
Y	Lens	W	Wide Field of View - 5.2 mm Focal Length Lens
		M	Medium Field of View – 7.7 mm Focal Length Lens
ZZZ	Sensor	03M	752 x 480 (0.3 MP) Pixel, Mono Sensor, Global Shutter
		12M	1280 x 960 (1.2 MP) Pixel, Mono Sensor, Global Shutter
		50C	2592 x 1944 (5 MP) Pixel, Color Sensor, Rolling Shutter
P	Software License	S	AutoVISION Sensor (Vision Toolset Only)
		A	AutoVISION (Vision and Code Reading / Verification Toolsets)
		V	Visionscape (Full AutoVISION and Visionscape Toolsets)

1b) F330-F Mono and Color Camera with Narrow Lens: Valid Combinations

Note: 50 mm Fixed Focus option not available with Narrow Lens.

F330-F[XXX]N[ZZZ]-NN[P]

Key	Classification	Code	Meaning
XXX	Focus Distance (mm)	064	Fixed Focus at 64 mm
		081	Fixed Focus at 81 mm
		102	Fixed Focus at 102 mm
		133	Fixed Focus at 133 mm
		190	Fixed Focus at 190 mm
		300	Fixed Focus at 300 mm
ZZZ	Sensor	03M	752 x 480 (0.3 MP) Pixel, Mono Sensor, Global Shutter
		12M	1280 x 960 (1.2 MP) Pixel, Mono Sensor, Global Shutter
		50C	2592 x 1944 (5 MP) Pixel, Color Sensor, Rolling Shutter
P	Software License	S	AutoVISION Sensor (Vision Toolset Only)
		A	AutoVISION (Vision and Code Reading / Verification Toolsets)
		V	Visionscape (Full AutoVISION and Visionscape Toolsets)

F420-F Part Number Structure

Use this legend when defining product part numbers. Please note that not all combinations of parameters are valid. For instance, color cameras are only available with white lighting, and 400 mm fixed focus is only available with UHD lenses. When ordering, use valid part numbers from the tables in the Ordering Information section only.

F420-F[XXX][Y][ZZZ]-[L][C][P]

Key	Classification	Code	Meaning
XXX	Focus Distance (mm)	000	Autofocus – Variable Distance
		050	Fixed Focus at 50 mm
		064	Fixed Focus at 64 mm
		081	Fixed Focus at 81 mm
		102	Fixed Focus at 102 mm
		133	Fixed Focus at 133 mm
		190	Fixed Focus at 190 mm
		300	Fixed Focus at 300 mm
		400	Fixed Focus at 400 mm
Y	Lens	W	Wide Field of View – 5.2 mm Focal Length Lens
		M	Medium Field of View – 7.7 mm Focal Length Lens
		N	Narrow Field of View – 16 mm Focal Length Lens
		L	Narrow 16 mm Lens – Autofocus to 1160 mm
ZZZ	Sensor	03M	752 x 480 (0.3 MP) Pixel, Mono Sensor, Global Shutter
		12M	1280 x 960 (1.2 MP) Pixel, Mono Sensor, Global Shutter
		50C	2592 x 1944 (5 MP) Pixel, Color Sensor, Rolling Shutter
L	Light Type	N	No Outer Light
		S	Standard Outer Light
C	Light Color	N	No Outer Light
		R	Red
		W	White
P	Software License	S	AutoVISION Sensor (Vision Toolset Only)
		A	AutoVISION (Vision and Code Reading / Verification Toolsets)
		V	Visionscape (Full AutoVISION and Visionscape Toolsets)

Example Part Numbers:

- F420-F081W03M-NNS: Fixed Focus at 81 mm, Wide Lens, 0.3 MP Monochrome Sensor, No Outer Light, AutoVISION Sensor

F420-F Valid Product Matrix

Model	Category	Focus Type	Sensor	Lens	Focus Distance (mm)	Light	License
F420-F	Monochrome	Fixed Focus	03M, 12M	W, M	50, 64, 81, 102, 133, 190, 300	None, Red, White	S, A, V
			12M	N	64, 400	None, Red, White	S, A, V
		Autofocus	03M	W, M	50 <-> 300 Autofocus	None, Red, White	S, A, V
			12M	W, M, N	50 <-> 300 (W, M) 40 <-> 150 (N) Autofocus	None, Red, White	S, A, V
	Color	Fixed Focus	50C	W, M	50, 64, 81, 102, 133, 190, 300	None, White	S, A, V
		Autofocus	50C	W, M	50 <-> 300 Autofocus	None, White	S, A, V
	Specialty	Long Range Autofocus	12M	L	75 <-> 1160 Autofocus	None, Red, White	S, A, V

F420-F Ordering Information

Categories:

1. Fixed Focus Camera

- a.) F420-F Monochrome Fixed Focus Camera
- b.) F420-F Color Fixed Focus Camera
- c.) F420-F 1.2 MP Monochrome Fixed Focus Camera with Narrow Lens

2. Autofocus Camera

- a.) F420-F 0.3 MP Monochrome Autofocus Camera (50 – 300 mm)
- b.) F420-F 1.2 MP Monochrome Autofocus Camera (50 – 300 mm for Wide and Medium Lens, 40 – 150 mm for Narrow Lens)
- c.) F420-F Color Autofocus Camera (50 - 300 mm)
- d.) F420-F 1.2 MP Monochrome Long Range Autofocus Camera (75 - 1160 mm)

1a) F420-F Monochrome Fixed Focus Camera: Valid Combinations

F420-F[XXX][Y][ZZZ]-[L][C][P]

Key	Classification	Code	Meaning
XXX	Focus Distance (mm)	050	Fixed Focus at 50 mm
		064	Fixed Focus at 64 mm
		081	Fixed Focus at 81 mm
		102	Fixed Focus at 102 mm
		300	Fixed Focus at 300 mm
Y	Lens	W	Wide Field of View - 5.2 mm Focal Length Lens
		M	Medium Field of View – 7.7 mm Focal Length Lens
ZZZ	Sensor	03M	752 x 480 (0.3 MP) Pixel, Mono Sensor, Global Shutter
		12M	1280 x 960 (1.2 MP) Pixel, Mono Sensor, Global Shutter
L	Light Type	N	No Outer Light
		S	Standard Outer Light
C	Light Color	N	No Outer Light
		R	Red
		W	White
P	Software License	S	AutoVISION Sensor (Vision Toolset Only)
		A	AutoVISION (Vision and Code Reading / Verification Toolsets)
		V	Visionscape (Full AutoVISION and Visionscape Toolsets)

1b) F420-F 5.0 MP Color Fixed Focus Camera: Valid Combinations

Note: 5 MP Color cameras are available with No or White light options only.

F420-F[XXX][Y]50C-[L][C][P]

Key	Classification	Code	Meaning
XXX	Focus Distance (mm)	050	Fixed Focus at 50 mm
		064	Fixed Focus at 64 mm
		081	Fixed Focus at 81 mm
		102	Fixed Focus at 102 mm
		300	Fixed Focus at 300 mm
Y	Lens	W	Wide Field of View - 5.2 mm Focal Length Lens
		M	Medium Field of View – 7.7 mm Focal Length Lens
L	Light Type	N	No Outer Light
		S	Standard Outer Light
C	Light Color	N	No Outer Light
		W	White
P	Software License	S	AutoVISION Sensor (Vision Toolset Only)
		A	AutoVISION (Vision and Code Reading / Verification Toolsets)
		V	Visionscape (Full AutoVISION and Visionscape Toolsets)

1c) F420-F 1.2 MP Monochrome Fixed Focus Camera with Narrow Lens: Valid Combinations

Note: Fixed Focus Narrow lens option available for 1.2 MP Mono camera only.

F420-F[XXX]N12M-[L][C][P]

Key	Classification	Code	Meaning
XXX	Focus Distance (mm)	064	Fixed Focus at 64 mm
		400	Fixed Focus at 400 mm
L	Light Type	N	No Outer Light
		S	Standard Outer Light
C	Light Color	N	No Outer Light
		R	Red
		W	White
P	Software License	S	AutoVISION Sensor (Vision Toolset Only)
		A	AutoVISION (Vision and Code Reading / Verification Toolsets)
		V	Visionscape (Full AutoVISION and Visionscape Toolsets)

2a) F420-F 0.3 MP Monochrome Autofocus Cameras (50 – 300 mm): Valid Combinations**F420-F000[Y]03M-[L][C][P]**

Key	Classification	Code	Meaning
Y	Lens	W	Wide Field of View - 5.2 mm Focal Length Lens
		M	Medium Field of View – 7.7 mm Focal Length Lens
ZZZ	Sensor	03M	752 x 480 (0.3 MP) Pixel, Mono Sensor, Global Shutter
		12M	1280 x 960 (1.2 MP) Pixel, Mono Sensor, Global Shutter
L	Light Type	N	No Outer Light
		S	Standard Outer Light
C	Light Color	N	No Outer Light
		R	Red
		W	White
P	Software License	S	AutoVISION Sensor (Vision Toolset Only)
		A	AutoVISION (Vision and Code Reading / Verification Toolsets)
		V	Visionscape (Full AutoVISION and Visionscape Toolsets)

2b) F420-F 1.2 MP Monochrome Autofocus Camera (50 – 300 mm for Wide and Medium, 40 – 150 mm for Narrow): Valid Combinations**F420-F000[Y]12M-[L][C][P]**

Key	Classification	Code	Meaning
Y	Lens	W	Wide Field of View - 5.2 mm Focal Length Lens
		M	Medium Field of View – 7.7 mm Focal Length Lens
		N	Narrow Field of View – 16 mm Focal Length Lens
L	Light Type	N	No Outer Light
		S	Standard Outer Light
C	Light Color	N	No Outer Light
		R	Red
		W	White
P	Software License	S	AutoVISION Sensor (Vision Toolset Only)
		A	AutoVISION (Vision and Code Reading / Verification Toolsets)
		V	Visionscape (Full AutoVISION and Visionscape Toolsets)

2c) F420-F 5.0 MP Color Autofocus Camera (50 - 300 mm): Valid Combinations

Note: Narrow Autofocus lens option not available for color camera.

F420-F000[Y]50C-[L][C][P]

Key	Classification	Code	Meaning
Y	Lens	W	Wide Field of View - 5.2 mm Focal Length Lens
		M	Medium Field of View – 7.7 mm Focal Length Lens
L	Light Type	N	No Outer Light
		S	Standard Outer Light
C	Light Color	N	No Outer Light
		W	White
P	Software License	S	AutoVISION Sensor (Vision Toolset Only)
		A	AutoVISION (Vision and Code Reading / Verification Toolsets)
		V	Visionscape (Full AutoVISION and Visionscape Toolsets)

2d) F420-F 1.2 MP Monochrome Long Range Autofocus Camera (75 - 1160 mm): Valid Combinations

Note: Autofocus Long Range lens option available for 1.2 MP Monochrome camera only.

F420-F000L12M-[L][C][P]

Key	Classification	Code	Meaning
L	Light Type	N	No Outer Light
		S	Standard Outer Light
C	Light Color	N	No Outer Light
		R	Red
		W	White
P	Software License	S	AutoVISION Sensor (Vision Toolset Only)
		A	AutoVISION (Vision and Code Reading / Verification Toolsets)
		V	Visionscape (Full AutoVISION and Visionscape Toolsets)

F430-F Part Number Structure

Use this legend when defining product part numbers. Please note that not all combinations of parameters are valid. For instance, color cameras are only available with white lighting, and 400 mm fixed focus is only available with UHD lenses. When ordering, use valid part numbers from the tables in the Ordering Information section only.

F430-F[XXX][Y][ZZZ]-[L][C][P]

Key	Classification	Code	Meaning
XXX	Focus Distance (mm)	000	Autofocus – Variable Distance
		050	Fixed Focus at 50 mm
		064	Fixed Focus at 64 mm
		081	Fixed Focus at 81 mm
		102	Fixed Focus at 102 mm
		133	Fixed Focus at 133 mm
		190	Fixed Focus at 190 mm
		300	Fixed Focus at 300 mm
		400	Fixed Focus at 400 mm
Y	Lens	W	Wide Field of View – 5.2 mm Focal Length Lens
		M	Medium Field of View – 7.7 mm Focal Length Lens
		N	Narrow Field of View – 16 mm Focal Length Lens
		L	Narrow 16 mm Lens – Autofocus to 1160 mm
ZZZ	Sensor	03M	752 x 480 (0.3 MP) Pixel, Mono Sensor, Global Shutter
		12M	1280 x 960 (1.2 MP) Pixel, Mono Sensor, Global Shutter
		50C	2592 x 1944 (5 MP) Pixel, Color Sensor, Rolling Shutter
L	Light Type	N	No Outer Light
		S	Standard Outer Light
		R	Ring Light
C	Light Color	N	No Outer Light
		R	Red
		W	White
P	Software License	S	AutoVISION Sensor (Vision Toolset Only)
		A	AutoVISION (Vision and Code Reading / Verification Toolsets)
		V	Visionscape (Full AutoVISION and Visionscape Toolsets)

Example Part Numbers:

- F430-F081W03M-NNS: Fixed Focus at 81 mm, Wide Lens, 0.3 MP Monochrome Sensor, No Outer Light, AutoVISION Sensor
- F430-F000N12M-RRA: Autofocus, Narrow Lens, 1.2 MP Mono, Ring Light, Red, AutoVISION + Verification

F430-F Valid Product Matrix

Model	Category	Focus Type	Sensor	Lens	Focus Distance (mm)	Light	License
F430-F	Monochrome	Fixed Focus	03M, 12M	W, M	50, 64, 81, 102, 133, 190, 300	None, Red, White	S, A, V
			12M	N	64, 400	None, Red, White	S, A, V
		Autofocus	03M	W, M	50 <-> 300 Autofocus	None, Red, White	S, A, V
			12M	W, M, N	50 <-> 300 (W and M) 40 <-> 150 (N) Autofocus	None, Red, White	S, A, V
	Color	Fixed Focus	50C	W, M	50, 64, 81, 102, 133, 190, 300	None, White	S, A, V
		Autofocus	50C	W, M	50 <-> 300 Autofocus	None, White	S, A, V
	Specialty	Ring Light Autofocus	12M	M, N	50 <-> 300 (M) 40 <-> 150 (N) Autofocus	Red, White (Ring)	S, A, V
		Long Range Autofocus	12M	L	75 <-> 1160 Autofocus	None, Red, White	S, A, V

F430-F Ordering Information

Categories:

1. Fixed Focus Camera

- a.) F430-F Monochrome Fixed Focus Camera
- b.) F430-F Color Fixed Focus Camera
- c.) F430-F 1.2 MP Monochrome Fixed Focus Camera with Narrow Lens

2. Autofocus Camera

- a.) F430-F 0.3 MP Monochrome Autofocus Camera (50 – 300 mm)
- b.) F430-F 1.2 MP Monochrome Autofocus Camera (50 – 300 mm for Wide and Medium Lens, 40 – 150 mm for Narrow Lens)
- c.) F430-F Color Autofocus Camera (50 - 300 mm)
- d.) F430-F 1.2 MP Monochrome Autofocus Camera with Ring Light (50 – 300 mm for Medium Lens, 40 – 150 mm for Narrow Lens)
- e.) F430-F 1.2 MP Monochrome Long Range Autofocus Camera (75 - 1160 mm)

1a) F430-F Monochrome Fixed Focus Camera: Valid Combinations

F430-F[XXX][Y][ZZZ]-[L][C][P]

Key	Classification	Code	Meaning
XXX	Focus Distance (mm)	050	Fixed Focus at 50 mm
		064	Fixed Focus at 64 mm
		081	Fixed Focus at 81 mm
		102	Fixed Focus at 102 mm
		300	Fixed Focus at 300 mm
Y	Lens	W	Wide Field of View - 5.2 mm Focal Length Lens
		M	Medium Field of View – 7.7 mm Focal Length Lens
ZZZ	Sensor	03M	752 x 480 (0.3 MP) Pixel, Mono Sensor, Global Shutter
		12M	1280 x 960 (1.2 MP) Pixel, Mono Sensor, Global Shutter
L	Light Type	N	No Outer Light
		S	Standard Outer Light
C	Light Color	N	No Outer Light
		R	Red
		W	White
P	Software License	S	AutoVISION Sensor (Vision Toolset Only)
		A	AutoVISION (Vision and Code Reading / Verification Toolsets)
		V	Visionscape (Full AutoVISION and Visionscape Toolsets)

1b) F430-F 5.0 MP Color Fixed Focus Camera: Valid Combinations

Note: 5 MP Color cameras are available with No or White light options only.

F430-F[XXX][Y]50C-[L][C][P]

Key	Classification	Code	Meaning
XXX	Focus Distance (mm)	050	Fixed Focus at 50 mm
		064	Fixed Focus at 64 mm
		081	Fixed Focus at 81 mm
		102	Fixed Focus at 102 mm
		300	Fixed Focus at 300 mm
Y	Lens	W	Wide Field of View - 5.2 mm Focal Length Lens
		M	Medium Field of View – 7.7 mm Focal Length Lens
L	Light Type	N	No Outer Light
		S	Standard Outer Light
C	Light Color	N	No Outer Light
		W	White
P	Software License	S	AutoVISION Sensor (Vision Toolset Only)
		A	AutoVISION (Vision and Code Reading / Verification Toolsets)
		V	Visionscape (Full AutoVISION and Visionscape Toolsets)

1c) F430-F 1.2 MP Monochrome Fixed Focus Camera with Narrow Lens: Valid Combinations

Note: Fixed Focus Narrow lens option available for 1.2 MP Mono camera only.

F430-F[XXX]N12M-[L][C][P]

Key	Classification	Code	Meaning
XXX	Focus Distance (mm)	064	Fixed Focus at 64 mm
		400	Fixed Focus at 400 mm
L	Light Type	N	No Outer Light
		S	Standard Outer Light
C	Light Color	N	No Outer Light
		R	Red
		W	White
P	Software License	S	AutoVISION Sensor (Vision Toolset Only)
		A	AutoVISION (Vision and Code Reading / Verification Toolsets)
		V	Visionscape (Full AutoVISION and Visionscape Toolsets)

2a) F430-F 0.3 MP Monochrome Autofocus Cameras (50 – 300 mm): Valid Combinations**F430-F000[Y]03M-[L][C][P]**

Key	Classification	Code	Meaning
Y	Lens	W	Wide Field of View - 5.2 mm Focal Length Lens
		M	Medium Field of View – 7.7 mm Focal Length Lens
ZZZ	Sensor	03M	752 x 480 (0.3 MP) Pixel, Mono Sensor, Global Shutter
		12M	1280 x 960 (1.2 MP) Pixel, Mono Sensor, Global Shutter
L	Light Type	N	No Outer Light
		S	Standard Outer Light
C	Light Color	N	No Outer Light
		R	Red
		W	White
P	Software License	S	AutoVISION Sensor (Vision Toolset Only)
		A	AutoVISION (Vision and Code Reading / Verification Toolsets)
		V	Visionscape (Full AutoVISION and Visionscape Toolsets)

2b) F430-F 1.2 MP Monochrome Autofocus Camera (50 – 300 mm for Wide and Medium, 40 – 150 mm for Narrow): Valid Combinations**F430-F000[Y]12M-[L][C][P]**

Key	Classification	Code	Meaning
Y	Lens	W	Wide Field of View – 5.2 mm Focal Length Lens
		M	Medium Field of View – 7.7 mm Focal Length Lens
		N	Narrow Field of View – 16 mm Focal Length Lens
L	Light Type	N	No Outer Light
		S	Standard Outer Light
C	Light Color	N	No Outer Light
		R	Red
		W	White
P	Software License	S	AutoVISION Sensor (Vision Toolset Only)
		A	AutoVISION (Vision and Code Reading / Verification Toolsets)
		V	Visionscape (Full AutoVISION and Visionscape Toolsets)

2c) F430-F 5.0 MP Color Autofocus Camera (50 - 300 mm): Valid Combinations

Note: Narrow Autofocus lens option not available for color camera.

F430-F000[Y]50C-[L][C][P]

Key	Classification	Code	Meaning
Y	Lens	W	Wide Field of View - 5.2 mm Focal Length Lens
		M	Medium Field of View – 7.7 mm Focal Length Lens
L	Light Type	N	No Outer Light
		S	Standard Outer Light
C	Light Color	N	No Outer Light
		W	White
P	Software License	S	AutoVISION Sensor (Vision Toolset Only)
		A	AutoVISION (Vision and Code Reading / Verification Toolsets)
		V	Visionscape (Full AutoVISION and Visionscape Toolsets)

2d) F430-F 1.2 MP Monochrome Autofocus Camera with Ring Light (50 – 300 mm for Medium, 40 – 150 mm for Narrow): Valid Combinations

Note: Ring Light version is available for Autofocus, Medium, and Narrow lens, 1.2 MP Monochrome camera only.

F430-F000[Y]12M-R[C][P]

Key	Classification	Code	Meaning
Y	Lens	M	Medium Field of View – 7.7 mm Focal Length Lens
		N	Narrow Field of View – 16 mm Focal Length Lens
C	Light Color	R	Red
		W	White
P	Software License	S	AutoVISION Sensor (Vision Toolset Only)
		A	AutoVISION (Vision and Code Reading / Verification Toolsets)
		V	Visionscape (Full AutoVISION and Visionscape Toolsets)

2e) F430-F 1.2 MP Monochrome Long Range Autofocus Camera (75 - 1160 mm): Valid Combinations

Note: Autofocus Long Range lens option available for 1.2 MP Monochrome camera only.

F430-F000L12M-[L][C][P]

Key	Classification	Code	Meaning
L	Light Type	N	No Outer Light
		S	Standard Outer Light
C	Light Color	N	No Outer Light
		R	Red
		W	White
P	Software License	S	AutoVISION Sensor (Vision Toolset Only)
		A	AutoVISION (Vision and Code Reading / Verification Toolsets)
		V	Visionscape (Full AutoVISION and Visionscape Toolsets)

2

System Components

This section contains camera dimensions, accessory dimensions, hardware configurations, wiring diagrams, trigger debounce information, and an explanation of F420-F and F430-F LED status indicators.

Note: There are no user-serviceable parts inside the camera.

2-1	Label Information	2-2
2-2	Camera Dimensions	2-3
2-3	Accessories	2-10
2-4	Hardware Configurations	2-24
2-5	Mounting the Camera	2-28
2-6	I/O Wiring	2-29
2-7	Grounding and Power	2-37
2-8	I/O Filtering and Debounce	2-39
2-9	Camera Definition File Example	2-40
2-10	Status Indicators	2-41

2-1 Label Information

Each MicroHAWK F320-F, F330-F, F420-F, and F430-F Smart Camera has a label that contains important information specific to that camera.

- **Part Number** – The part number of your camera.
- **Serial Number** – The serial number of your camera.
- **MAC Address** – The MAC address of your camera.

2-2 Camera Dimensions

Dimensions: mm [in.]

2

2-2-1 MicroHAWK F320-F Front

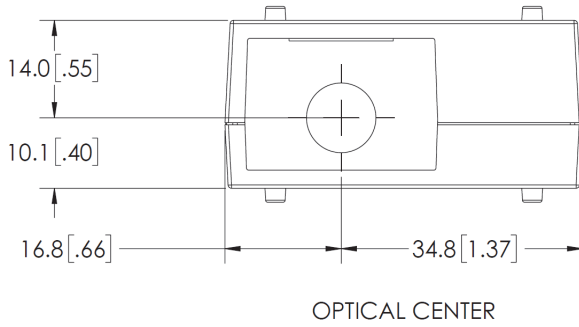

2-2-2 MicroHAWK F320-F Base

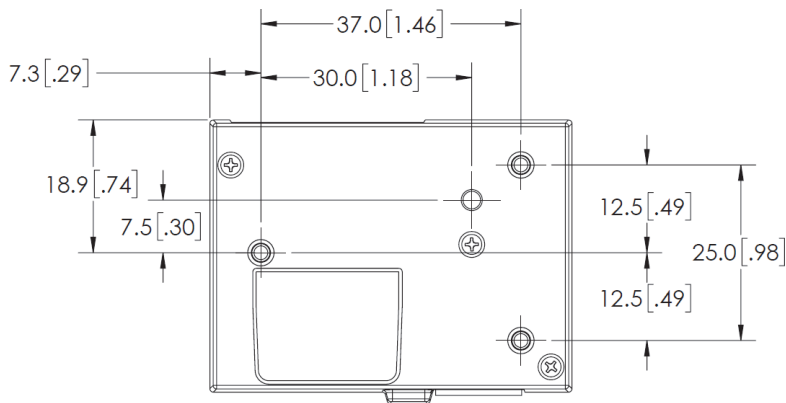

2-2-3 MicroHAWK F320-F Top

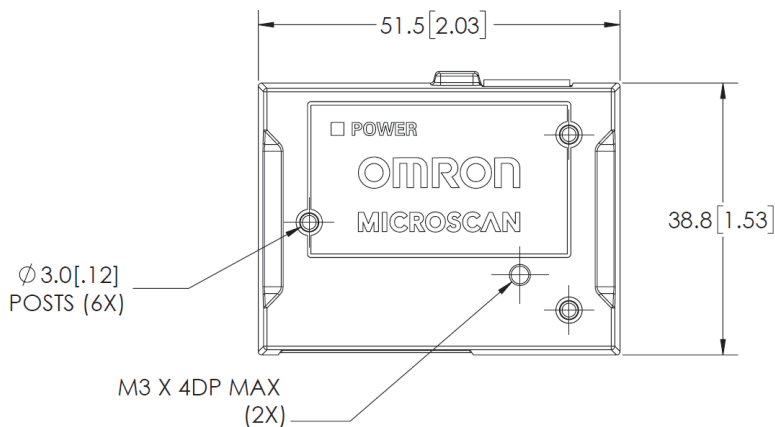

2-2-4 MicroHAWK F330-F Front

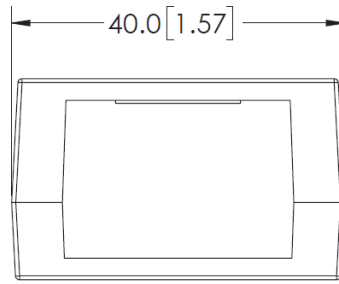

2-2-5 MicroHAWK F330-F Base

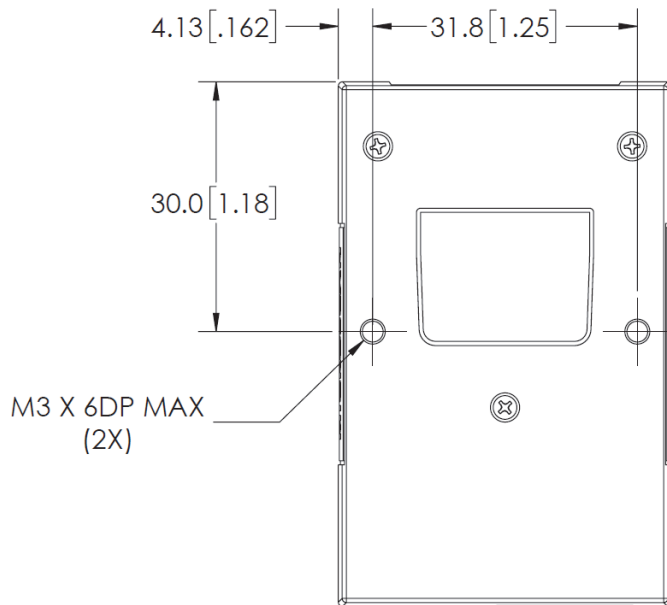

2-2-6 MicroHAWK F330-F Top

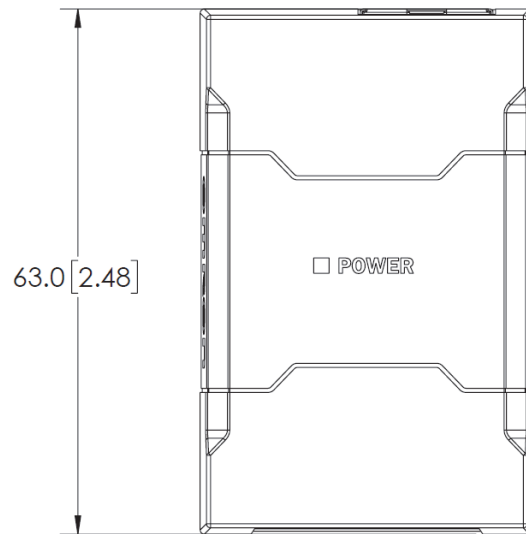

2-2-7 MicroHAWK F330-F Side

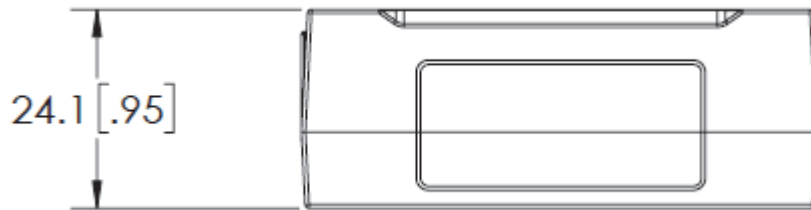

2-2-8 MicroHAWK F420-F Front

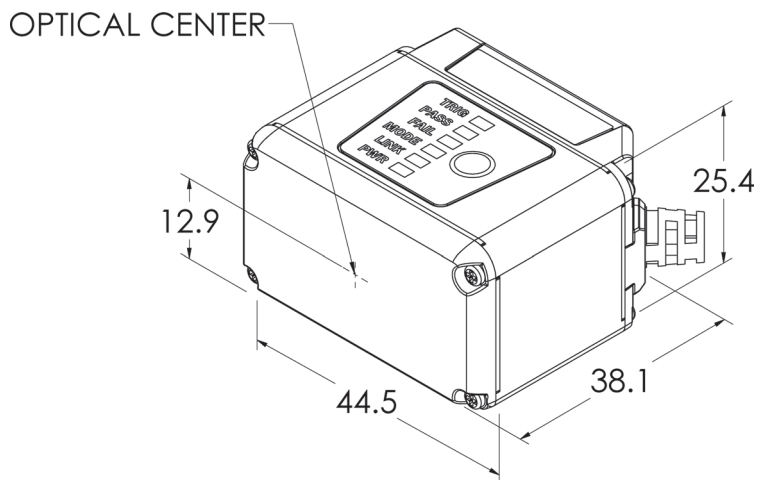

2-2-9 MicroHAWK F420-F Base

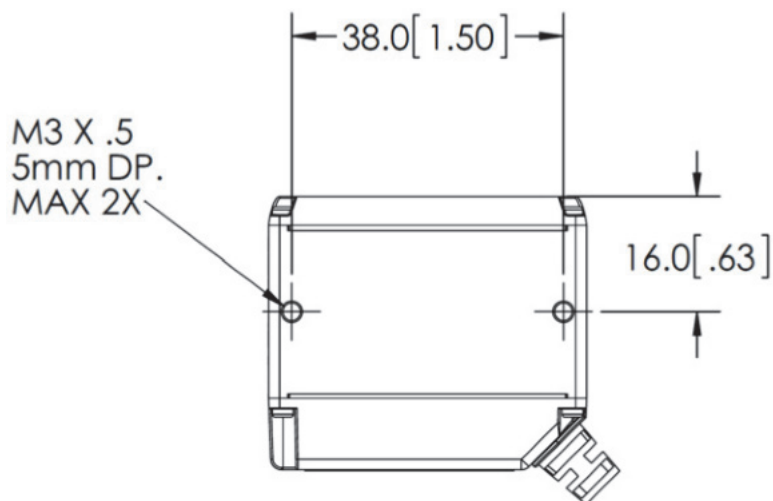

2-2-10 MicroHAWK F420-F Top

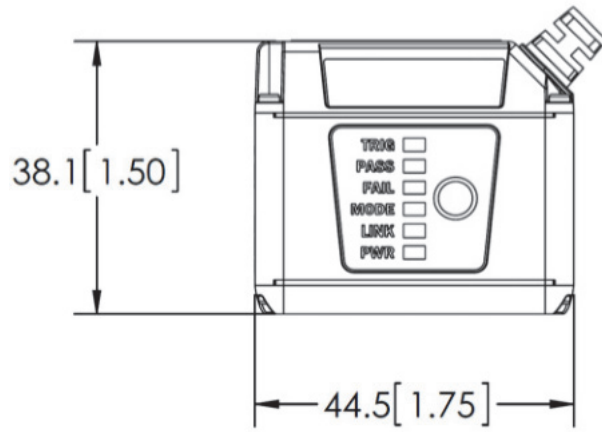

2-2-11 MicroHAWK F420-F Side

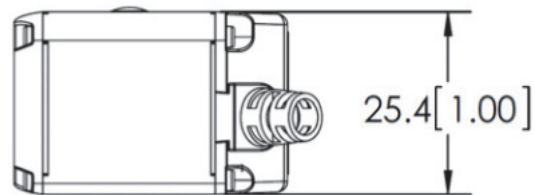

2-2-12 MicroHAWK F430-F Front

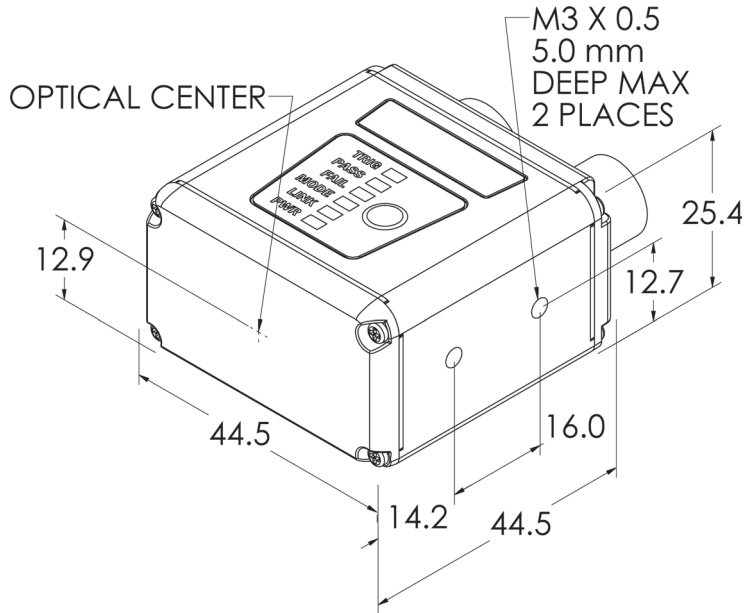

2-2-13 MicroHAWK F430-F Base

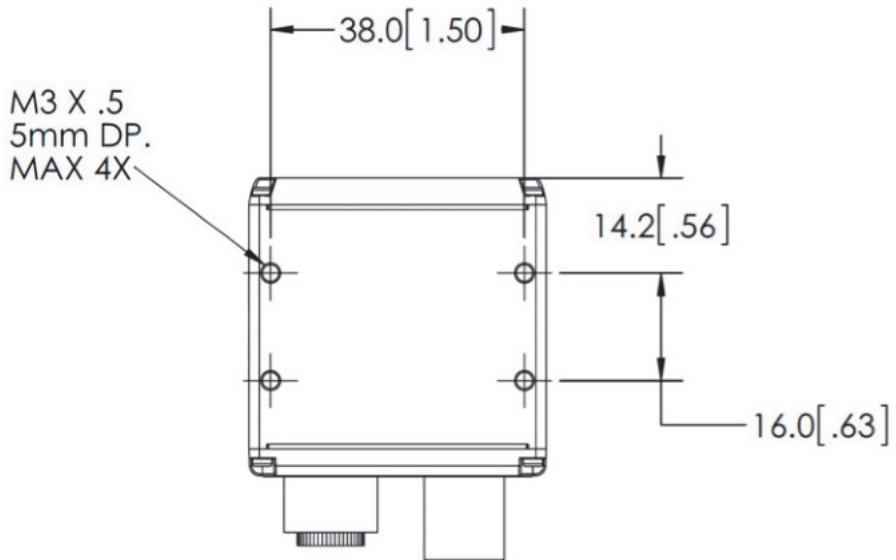

2-2-14 MicroHAWK F430-F Top

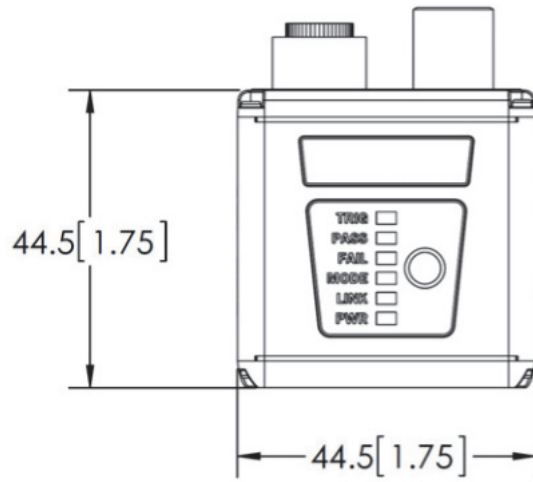

2

2-2-15 MicroHAWK F430-F Side

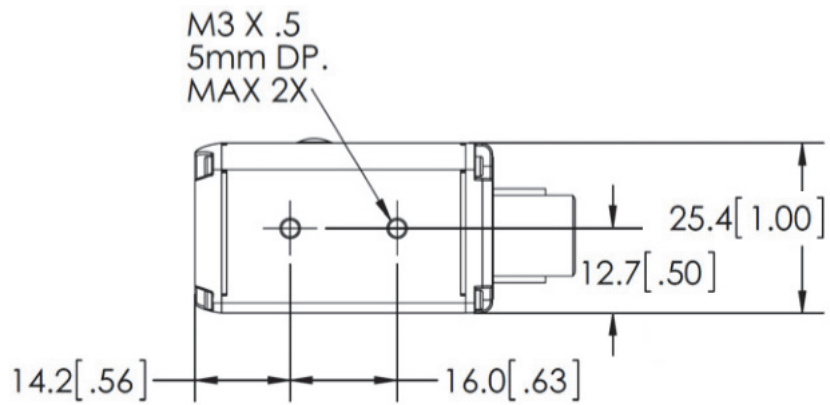

2-3 Accessories

2-3-1 MicroHAWK Accessories

✓ = Supported

x = Not Supported

Category	Part Number	Description	Camera				
			F420-F	F430-F	F430-F with Ring Light	F320-F	F330-F
Standard Optical Accessories and Lighting	V430-AF10	Front Window Installation Kit	✓	✓	x	x	x
	V430-AF11	Diffuser Installation Kit	✓	✓	x	x	x
	V430-AF12	Polarizer Installation Kit	✓	✓	x	x	x
	V430-AF3	Right-Angle Mirror Installation Kit	✓	✓	x	x	x
	V430-AF4	YAG Filter Installation Kit	✓	✓	x	x	x
	V430-AF5	ESD-Safe Window Installation Kit	✓	✓	x	x	x
	V430-AF6	Red Filter Installation Kit	✓	✓	x	x	x
	V430-AF7	Blue Filter Installation Kit	✓	✓	x	x	x
	V430-ALR	Red Light Installation Kit	✓	✓	x	x	x
	V430-ALW	White Light Installation Kit	✓	✓	x	x	x
	V430-ALB	Blue Light Installation Kit	✓	✓	x	x	x
	V430-ALI	IR Light Installation Kit	✓	✓	x	x	x
Ring F4X0-F Optical Accessories and Lighting	V430-AF0R	Front Window Installation Kit	x	x	✓	x	x
	V430-AF1R	Diffuser Installation Kit	x	x	✓	x	x
	V430-AF2R	Polarizer Installation Kit	x	x	✓	x	x
	V430-ALRR	Red Ring Light Installation Kit	x	x	✓	x	x
	V430-ALWR	White Ring Light Installation Kit	x	x	✓	x	x
	V430-ALBR	Blue Ring Light Installation Kit	x	x	✓	x	x
	V430-ALIR	IR Ring Light Installation Kit	x	x	✓	x	x
Mounting Accessories	V430-AM0	L-Bracket Adjustable-Angle Mounting Kit	✓	✓	✓	x	x
	V430-AM1	¼-20 Camera Mounting Block Kit	✓	✓	✓	x	x
	V430-AM2	4" (102 mm) Ram Mount Stand	✓	✓	✓	x	x
	V430-AM3	APG Pan and Tilt Camera Mount	✓	✓	✓	x	x
	V430-AM4	Nylon Screw and Washer Electrical Isolation Kit	✓	✓	✓	x	x
	V430-AM6	Smart Ring Light-to-F4X0-F Mounting Bracket	✓	✓	x	x	x
F3X0-F Optics Accessories	V330-AF1	Diffuser Kit – Peel and Stick Accessory	x	x	x	✓	✓
	V330-AF2	Polarizer Kit – Peel and Stick Accessory	x	x	x	✓	✓

2-3-2 Diffuser

V430-AF11

Spreads out light.

Reduces direct reflection of LEDs.

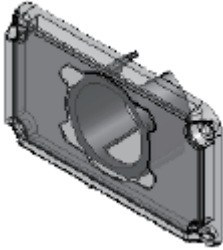

Accessories:
Gasket (1)
Phillips-Head Screws (4)

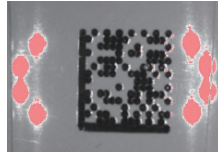

Without Diffuser



With Diffuser

2-3-3 Polarizer

V430-AF12

Reduces glare from specular objects.

Passes light from diffuse objects.

Filters out specular (vertical) reflection.

Only the horizontal component of diffuse reflection is "seen" by the camera.

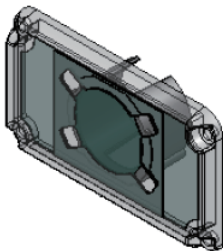

Accessories:
Gasket (1)
Phillips-Head Screws (4)

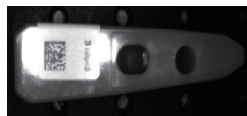

Without Polarizer

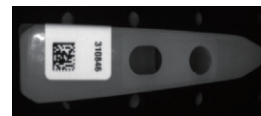

With Polarizer

How to Install V430-AF11/AF12

- Disconnect power from the camera.
- Remove the four screws from the front window of the camera.
- Remove the front window and gasket.
- Install the gasket onto the camera. Ensure that the gasket is properly seated in place and is covering all sealing surfaces.
- Install the window: V430-AF10 (or window accessory: V430-AF11/AF12) onto the camera.
- Secure the window in place using the screws provided. Do not over-tighten the screws. (1.0 in./lbs. (0.11 nm max.).



2-3-4 Right Angle Mirror

V430-AF3 (Unit: [mm])

Allows the camera to fit into compact spaces.
Reverses the image.

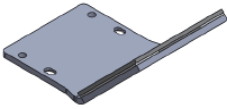

Bracket(1) (Material: Aluminum)
Mirror(1) (Material: Glass)

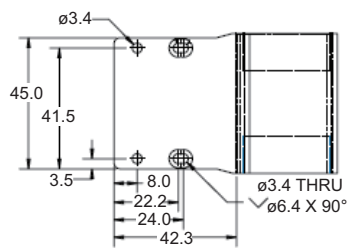
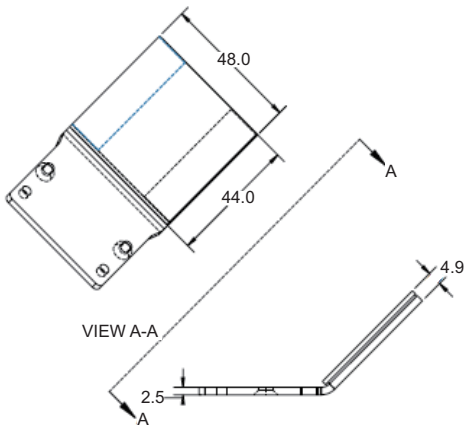
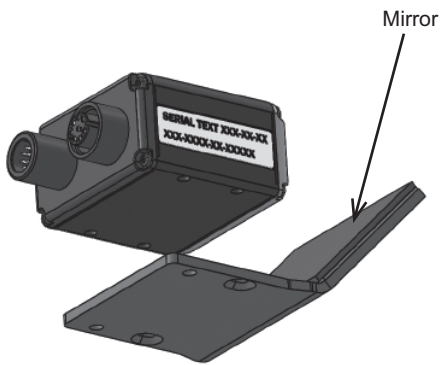

2-3-5 Mounting Bracket (Sold Separately)

Angle-Adjustable L Bracket

V430-AM0 (Unit: [mm])

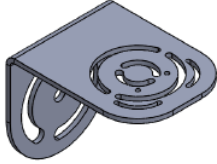

Material: SUS304
 Thickness: 2.5 mm
 Accessories: Phillips-HeadScrews (M3×6) (2)
 Washer (M3) (2)

The following accessories are not used with the MicroHAWK F430-F-Series:

- Phillips-Head Screws (M2×6) (2)
- Washers for M2 Screws (2)

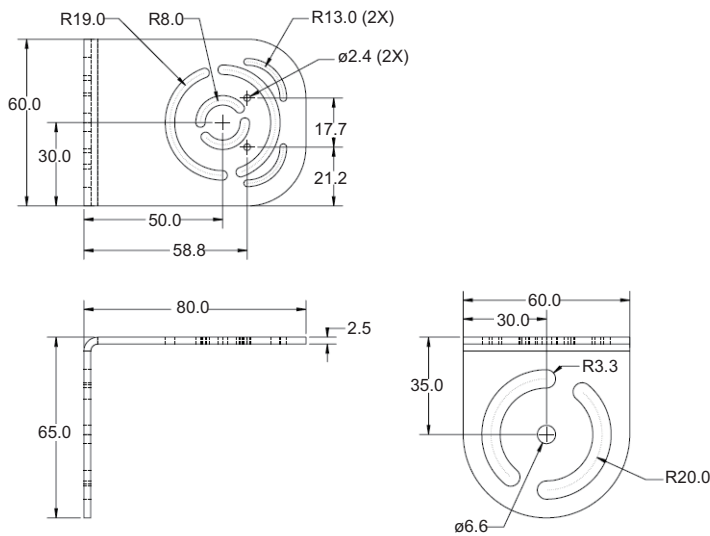

2

Installation Method

In case of side installation:

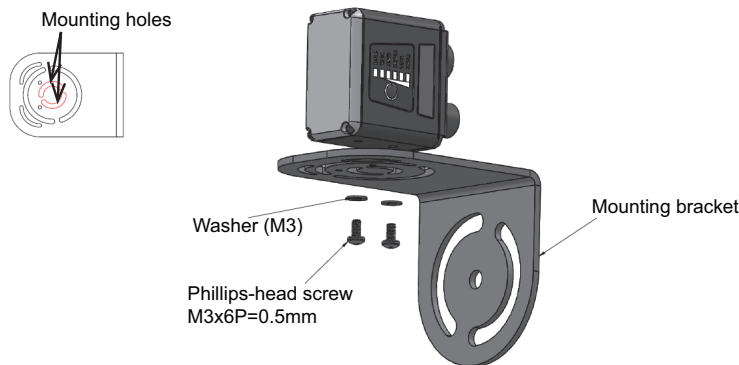

In case of base installation:

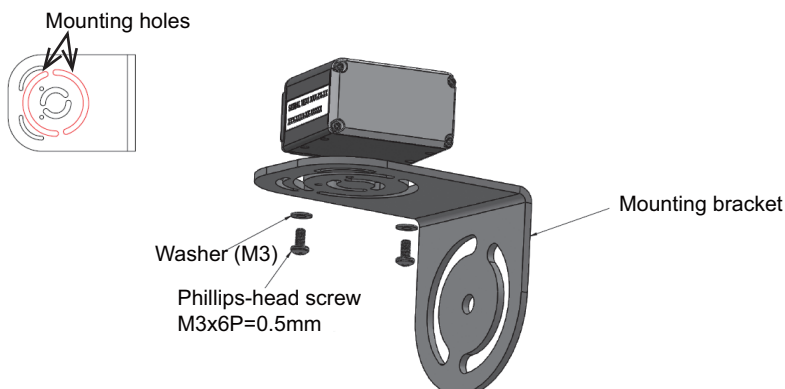

Mounting Block

V430-AM1 (Unit: [mm])



Material: Aluminum alloy
 Thickness: 6.4mm
 Accessories: Cap Screws (M3×6)(2)
 The following accessories are not used with the
 MicroHAWK F430-F-series:
 Cap Screws (M2×8)(2)

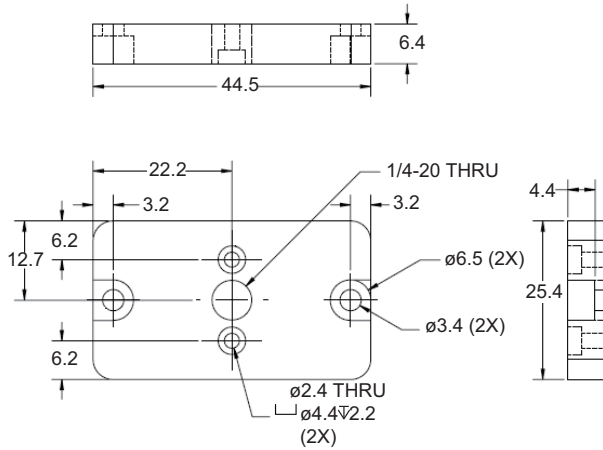

Mounting holes

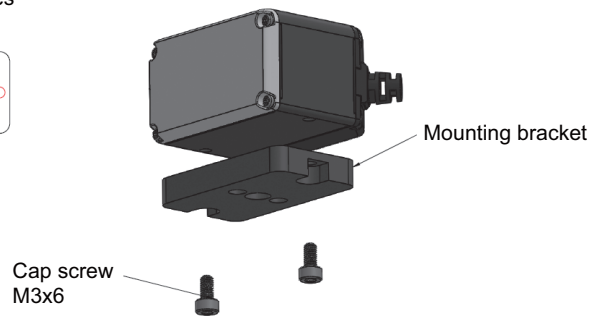
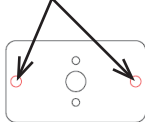

Note:

- Mounting the MicroHAWK F430-F requires the use of the front set of mounting holes, closest to the window.
- As the material is aluminum alloy, there is no isolation effect. Although the body case of F430-F is connected to FG (Frame ground), the FG is isolated from the internal electric circuit GND (0 VDC). If noise affects it, take measures by referencing Grounding and Power section.

2-3-6 MicroHAWK F320-F and F330-F Accessories

Important: See [Appendix B - Cable Specifications](#) for cables, pin assignments, and wire colors.

Diffuser Kit – Peel and Stick Accessory. Exterior to unit.
V330-AF1

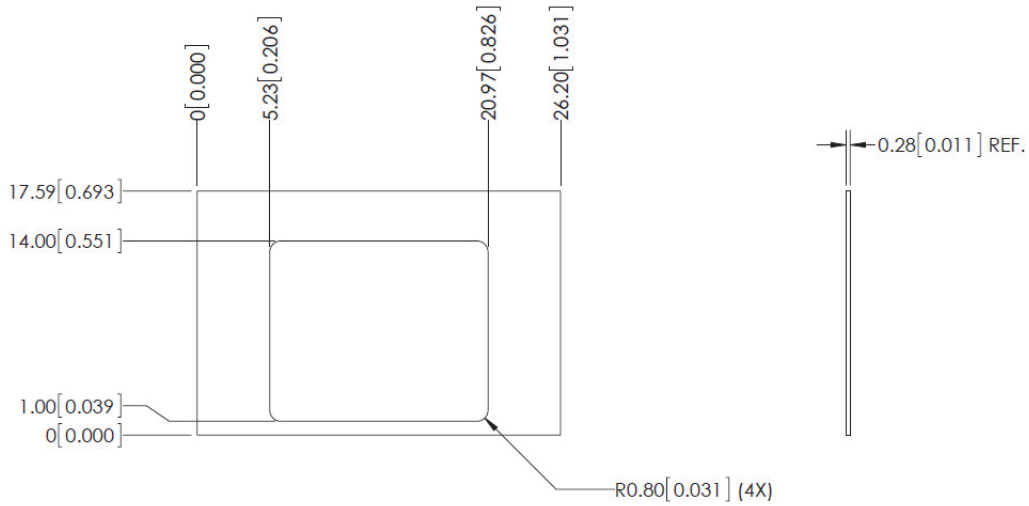

Polarizer Kit – Peel and Stick Accessory. Exterior to unit.
V330-AF2

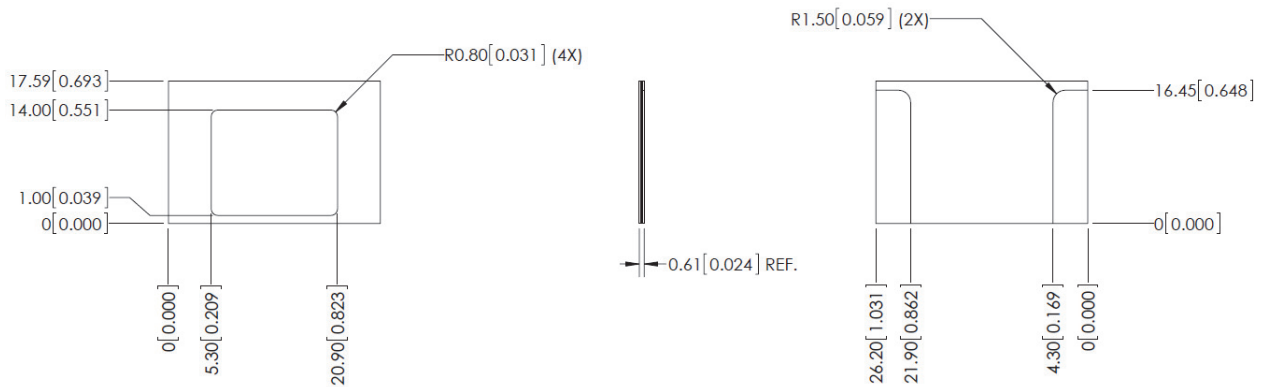
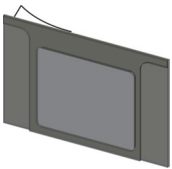

2-3-7 MicroHAWK F420-F and F430-F Accessories

**L Bracket Adjustable Angle Mounting Kit
V430-AM0**

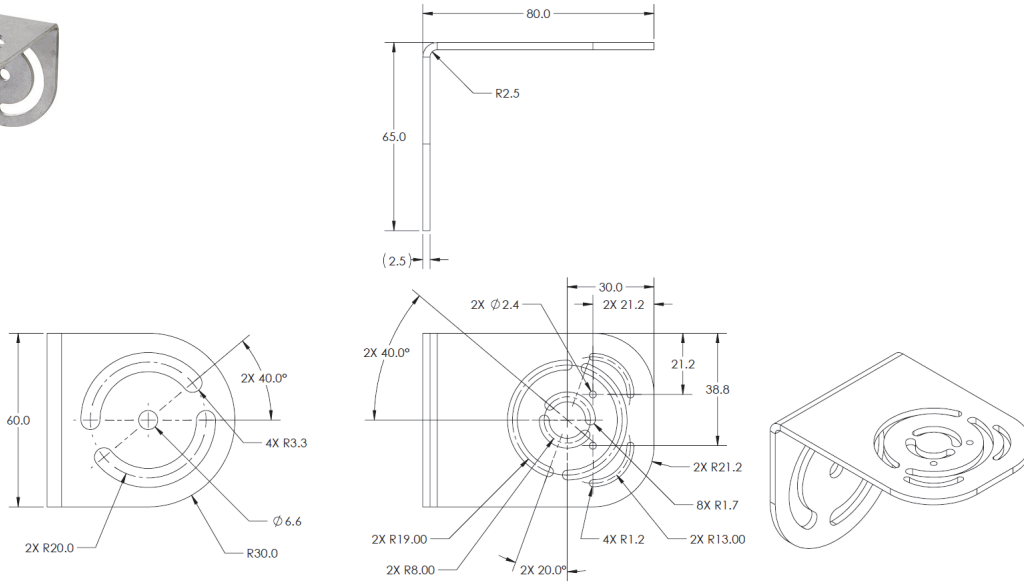

**1/4-20 Camera Mounting Block Kit
V430-AM1**

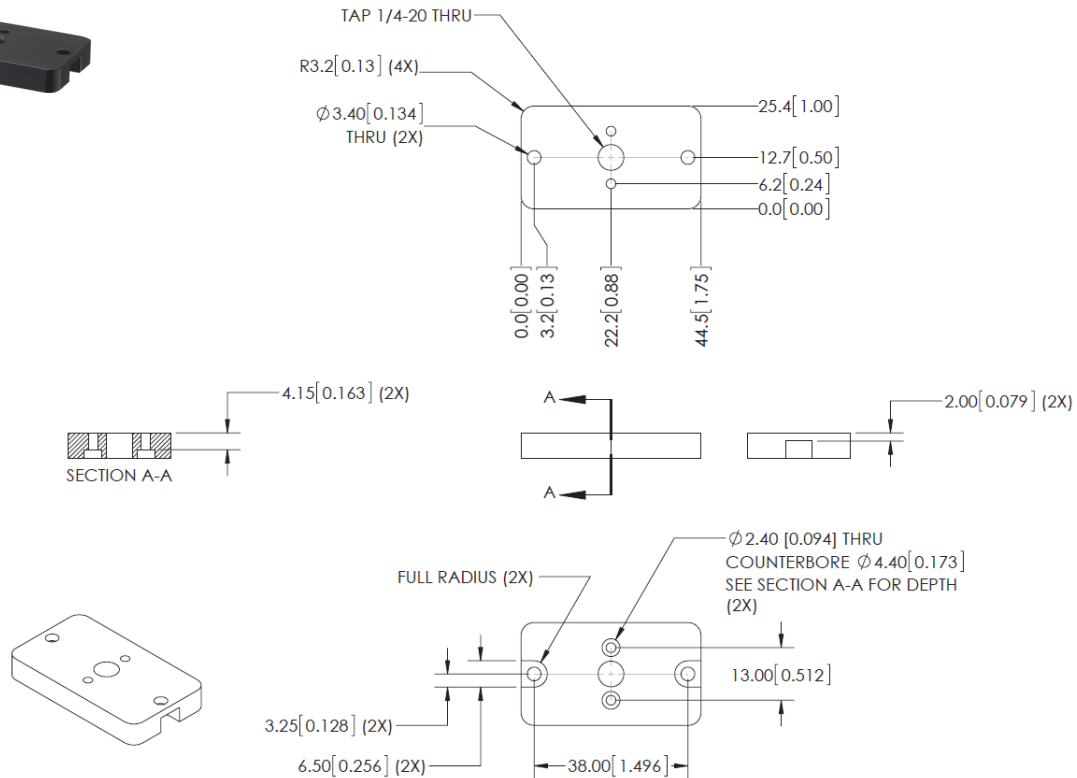

**4" (102 mm) Ram Mount Stand
V430-AM2**

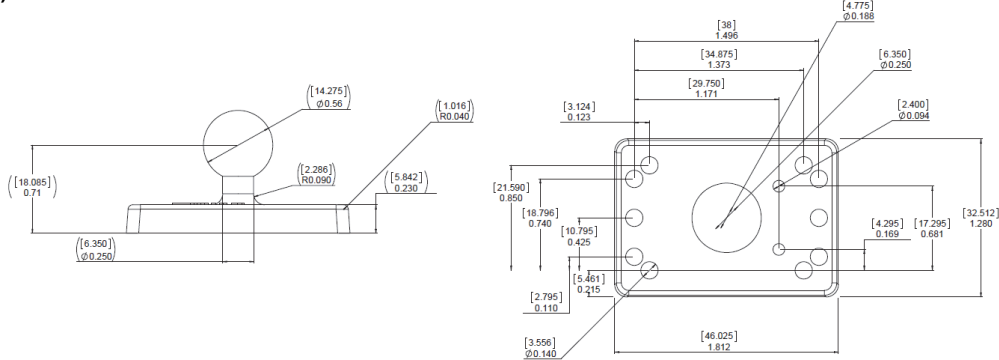

**MS-4 / MINI to V/F4XX-F Adapter Plate
V430-AM5**

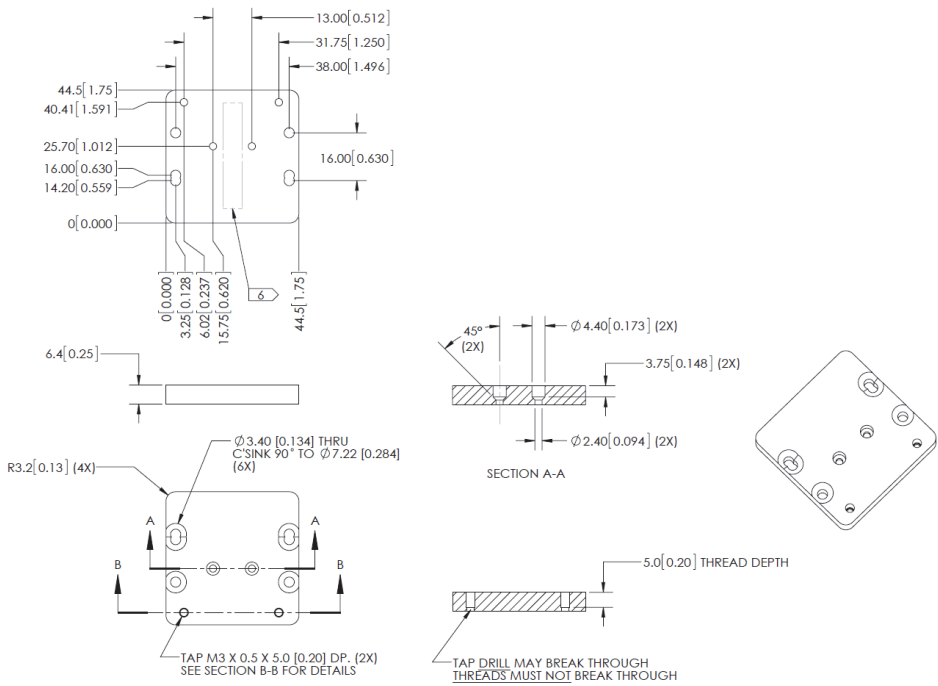
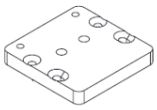

**APG Pan and Tilt Camera Mount
V430-AM3**

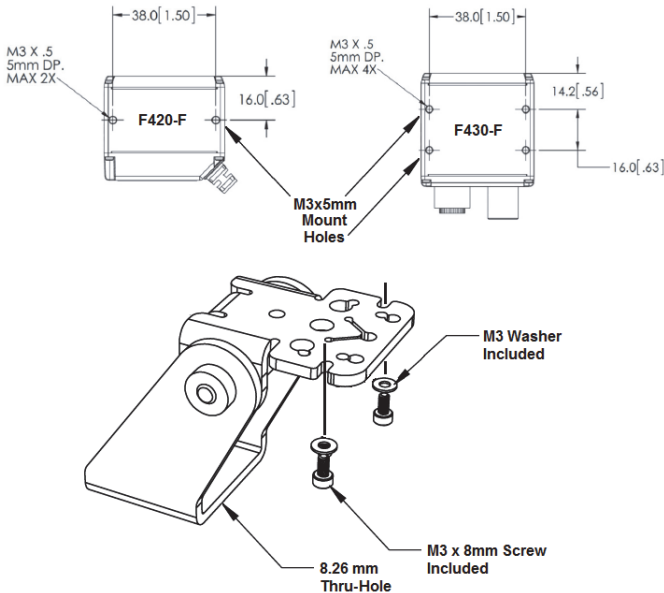

Smart Ring Light to V/F4XX-F Mounting Bracket V430-AM6

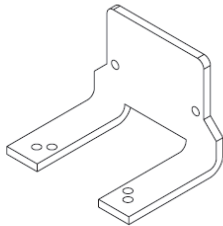
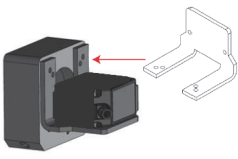

Screws required:
 2 M3x6 mm screws to mount light to bracket
 2 M3x6 mm screws to mount camera to bracket

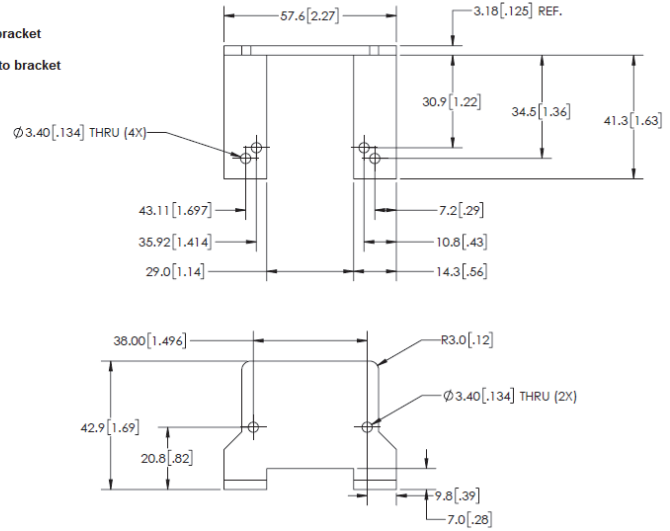
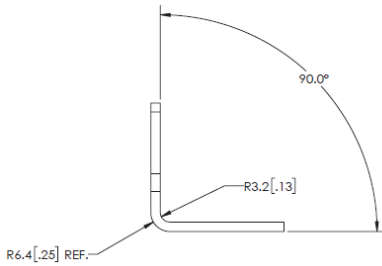
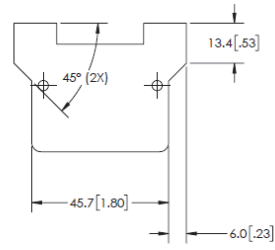

QX / Vision HAWK to V/F4XX-F Adapter Plate V430-AM7

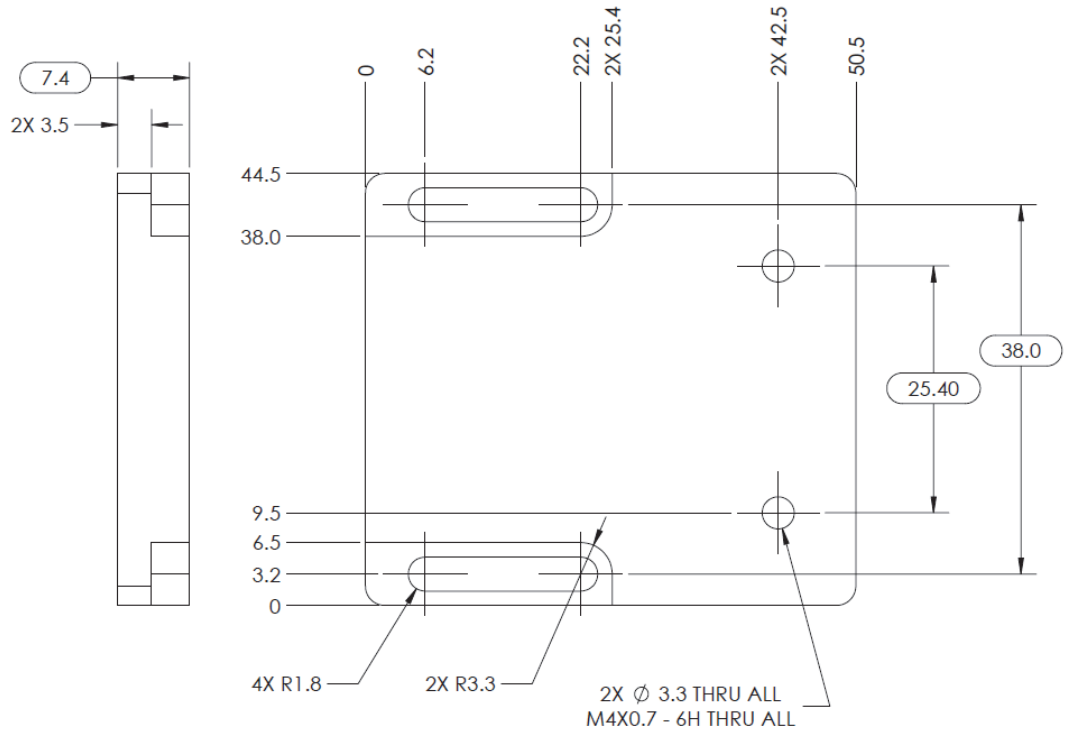
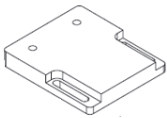

**Front Window Installation Kit
V430-AF10 ***

**Diffuser Installation Kit
V430-AF11 ***

**Polarizer Installation Kit
V430-AF12 ***

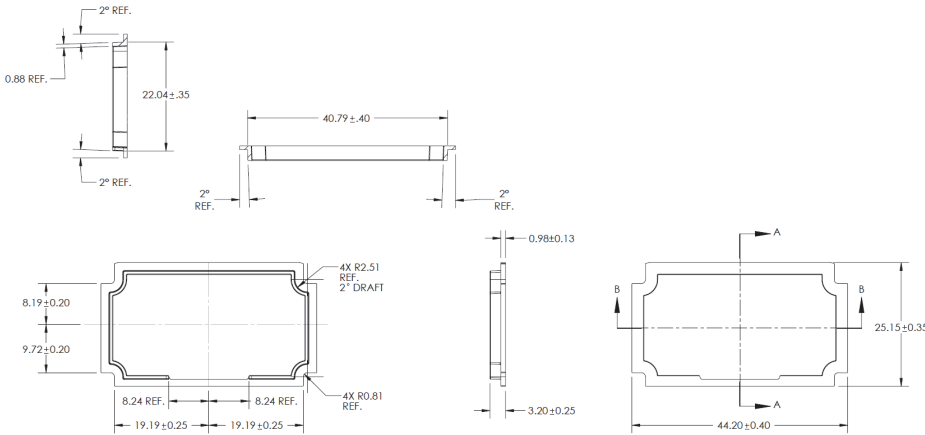
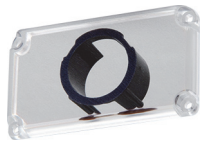

* **Note:** V430-AF10, AF11, and AF12 are used for **MicroHAWK V/F4X0-FXXXXXXX-XXX** cameras in this manual. The prior generation **MicroHAWK V430-FXXXXXXX** code camera uses part numbers V430-AF0, AF1, and AF2. Please select the correct accessory from the table based on your camera part number format.

Accessory	Prior V430-FXXXXXXX Code Reader	New V/F4X0-FXXXXXXX-XXX Code Reader and Smart Camera
Front Window Installation Kit	V430-AF0	V430-AF10
Diffuser Installation Kit	V430-AF1	V430-AF11
Polarizer Installation Kit	V430-AF2	V430-AF12

**Right Angle Mirror Installation Kit
V430-AF3**

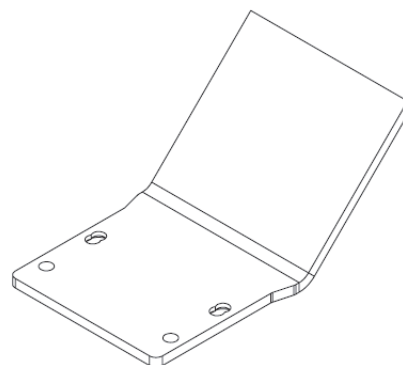
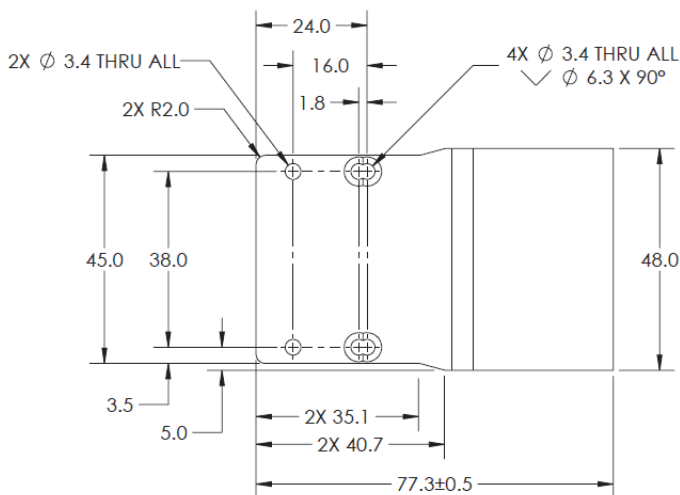
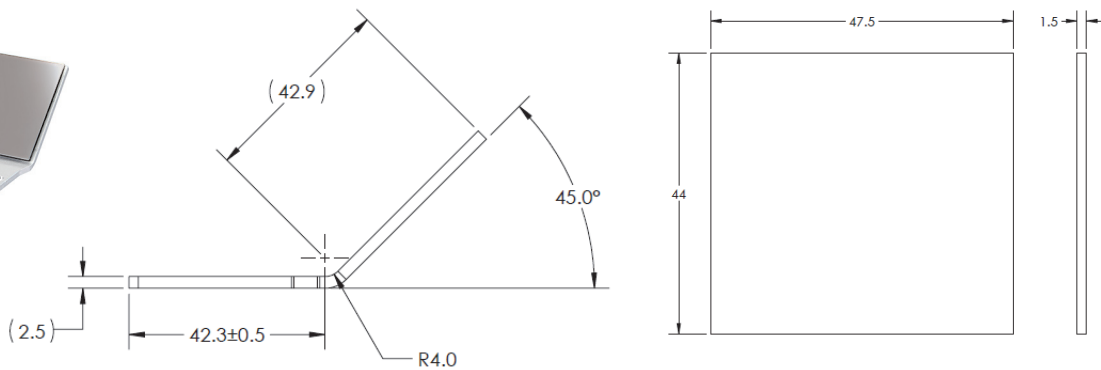

YAG Laser Filter Window V430-AF4

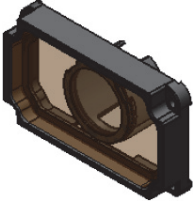

Window Material

Polymer

Laser Type

Argon

Broadband

KTP

Nd:YAG

Protection

OD 6+ @ 200-532 nm

OD 4+ @ 850-879 nm

OD 5+ @ 900-1070 nm

The V430-AF4 YAG Laser Filter is used to block a range of wavelengths from a variety of laser types from being seen by the MicroHAWK camera that will either disrupt the camera's view of the object, or damage the MicroHAWK sensor.

The table shows the laser types that are handled by the V430-AF4 Filter window, as well as the level of protection they provide at the various wavelengths.

Note: Optical Density (OD) is a measure of the attenuation of energy passing through a filter. The higher the OD value, the higher the attenuation and the greater the protection level.

OD 4 blocks 99.99% of the laser energy.

OD 5 blocks 99.999% of the laser energy (YAG).

OD 6 blocks 99.9999% of the laser energy (Argon, KTP)

ESD-Safe Window V430-AF5



An ESD event occurs when an electrostatic charge rapidly transfers between two objects. This transfer is usually caused when two objects with a notable potential difference in electrical charge contact each other. However, ESD events can also happen when two objects close to one another create a highly charged electrostatic field.

ESD safety precautions are extremely important in the electronics and semiconductor industries where sensitive components can be damaged even by a discharge of a mere 20 volts. Less sensitive components may still be susceptible, and cumulative discharges can create long-term problems affecting the functionality and performance of electronic components.

The MicroHAWK V430-AF5 ESD-Safe window is designed with an ESD coating on the exterior surface to prevent static discharge between the camera or smart camera when the camera is deployed close to the component surface. The antistatic coating offers a resistivity of $\leq 1.0 \times 10^9 \Omega/\text{sq}$ to prevent these electrostatic discharges.

**Red Filter Installation Kit
V430-AF6**

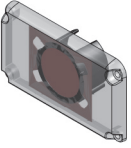

**Blue Filter Installation Kit
V430-AF7**

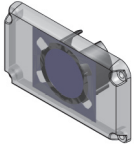

**Red Light Installation Kit
V430-ALR**

**White Light Installation Kit
V430-ALW**

**Blue Light Installation Kit
V430-ALB**

**IR Light Installation Kit
V430-ALI**

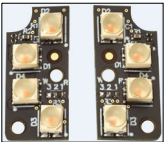

Red Filter (V430-AF6) and Blue Filter (V430-AF7)

The Red Filter (V430-AF6), and Blue Filter (V430-AF7) are used to turn MicroHAWKs equipped with white lights into units that emit red or blue light. MicroHAWK light color changes can be also be accomplished using the F430-F Red, Blue, White, or IR LED kits.

A typical example of how to use different color filters or LEDs with monochrome cameras is shown below. The emitted color is matched with the color of the part that needs to be emphasized or de-emphasized, which creates sufficient contrast for the part to be inspected or for the symbol to be decoded. In the example below, the red filter makes the reddish copper look bright, while the green circuit board looks dark. The blue filter produces the opposite effect.

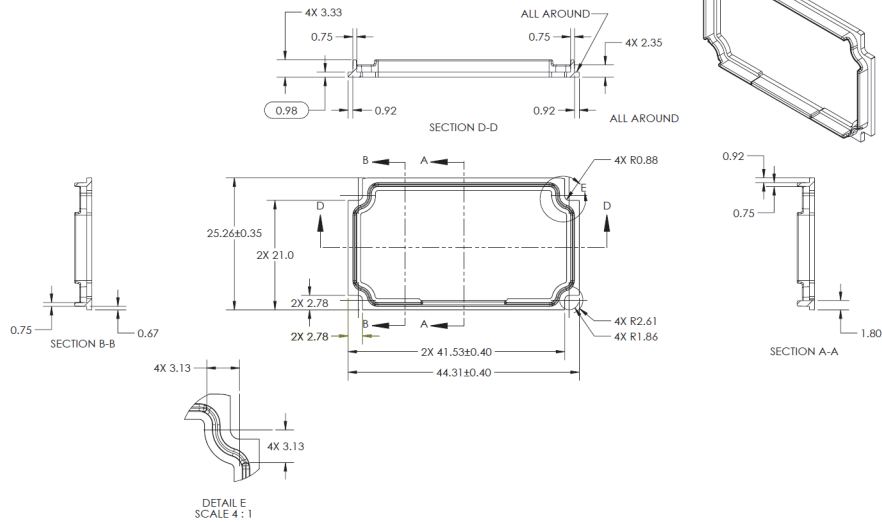
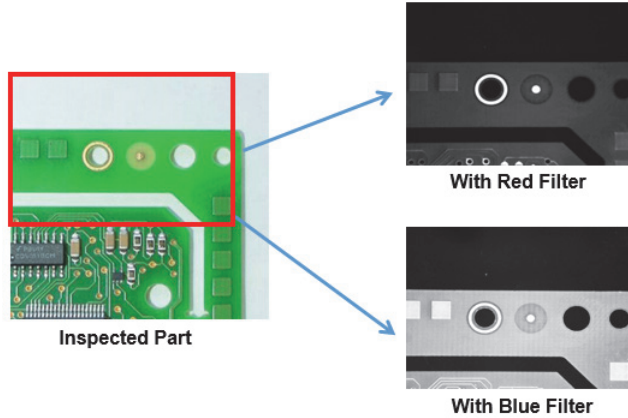

**QX-1 Interconnect Module – Power, Trigger, Smart Light Control Breakout
98-000103-02**

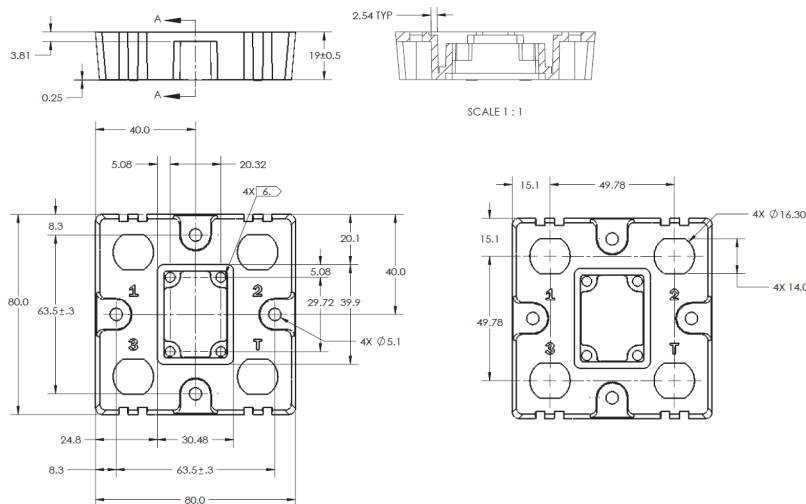

QX-1 Photo Sensor, M12 4-Pin Plug, NPN – 2 Meters – Light ON / Dark ON
99-900016-01

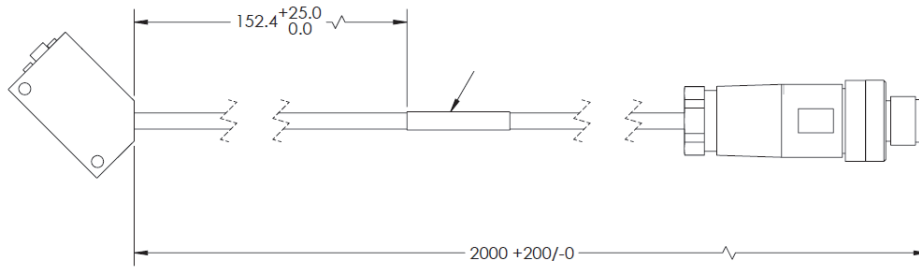

QX-1 Field-Wireable M12 4-Pin Plug for Any Trigger Source or Photo Sensor – Screw Terminals
98-9000239-01

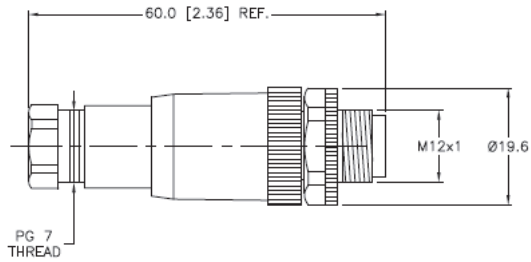

Power Supply, 100-240VAC, +24VDC, M12 12-Pin Socket – 1 Meter – U.S. / Euro Plug
97-000012-01

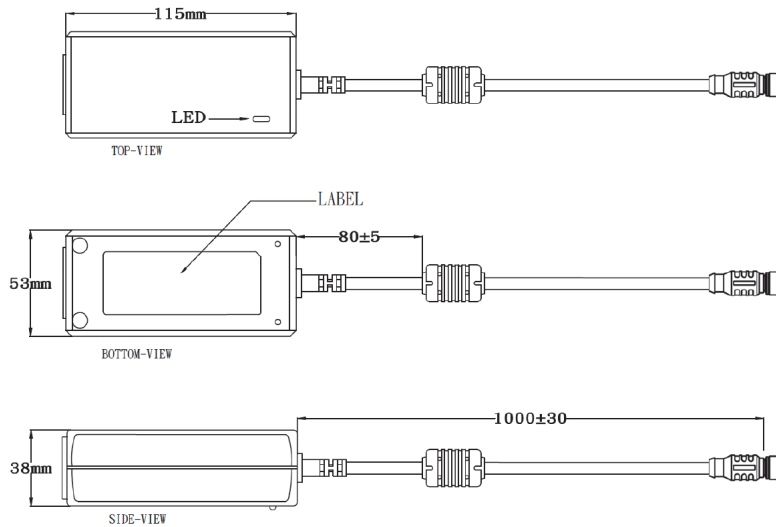

Omron Microscan Smart Light Series – Integrated Power and Strobe Control Module
 See Omron Microscan Smart Light Offering – Ring, DOAL, Large Area Lighting

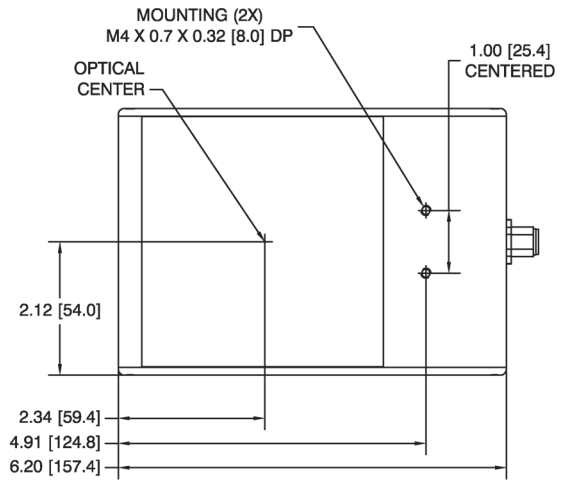
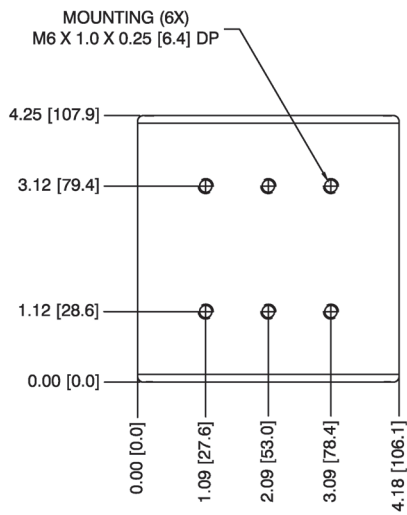
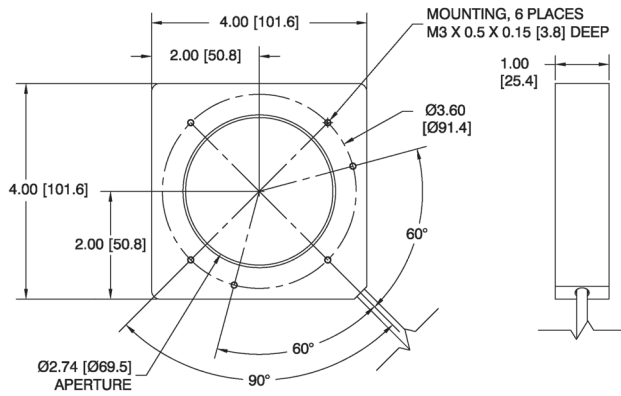

2

2-4 Hardware Configurations

Important: The following hardware configurations are examples only. Real-world application configurations may vary considerably from those shown below.

2-4-1 Check Hardware and Connect the System

MicroHAWK F320-F Configuration Options

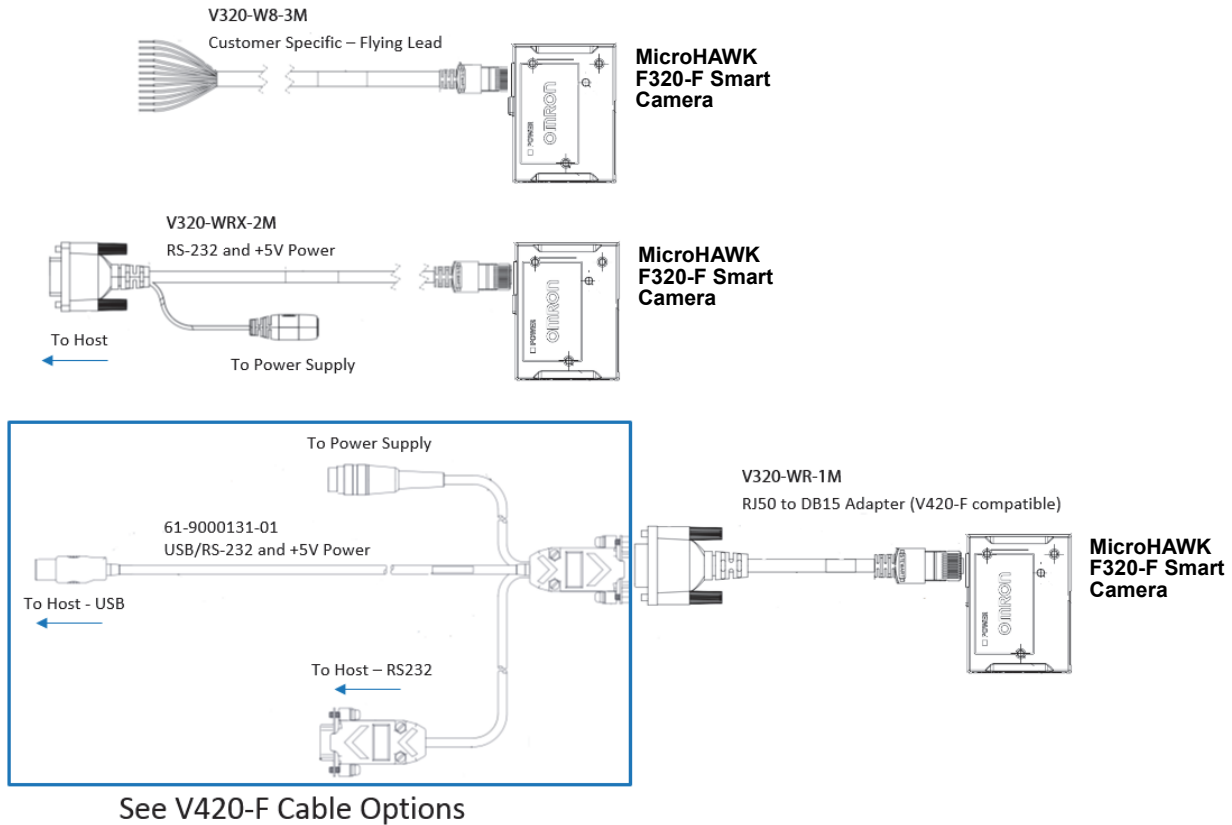

MicroHAWK F330-F Configuration Options

The F330-F supports Power over Ethernet (PoE), allowing you to power and communicate with the device from a single cable. The F330-F is considered a Class 0 PD (Powered Device) and will operate when connected to appropriate PoE PSE (Power Sourcing Equipment). The PSE will either provide power on an unused data pair (Alternative B) or on the data pair (Alternative A) which depends on the PSE. The F330-F supports both Mode A and Mode B per the PoE standard, IEEE802.3af.

When the F330-F is connected to the Cat5E cable, it will automatically present a Powered Device (PD) signature to the Power Sourcing Equipment (PSE), or PoE Mid-Span Equipment, when requested. The equipment will then recognize that a powered device is connected to that line and will supply power.

Omron recommends that you contact your network or IT administrator for further configuration details. You can connect to a non-PoE network using standard off-the-shelf PoE injectors, or network switches with PoE ports.

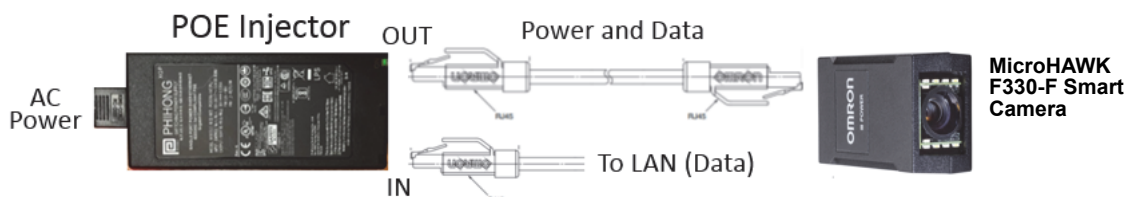

MicroHAWK F420-F Configuration Options

- Mount the camera securely in its stand (not supplied).
- Mount the camera as required by the application.
- Connect the integrated corner-exit cable to the MicroHAWK F420-F.
- Connect the accessory USB cable to the integrated corner-exit cable.
- Connect the USB Type A side of the USB cable to the host.
- Connect the power cable into the power source.

F420-F with DB15 to BUS Power USB Type A

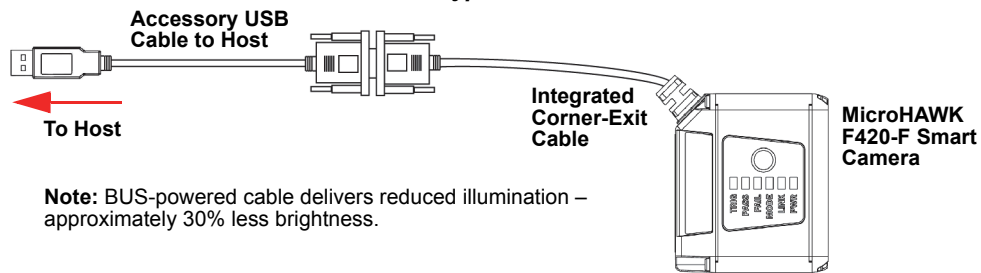

F420-F with DB15 to Ext. Power/USB Type A

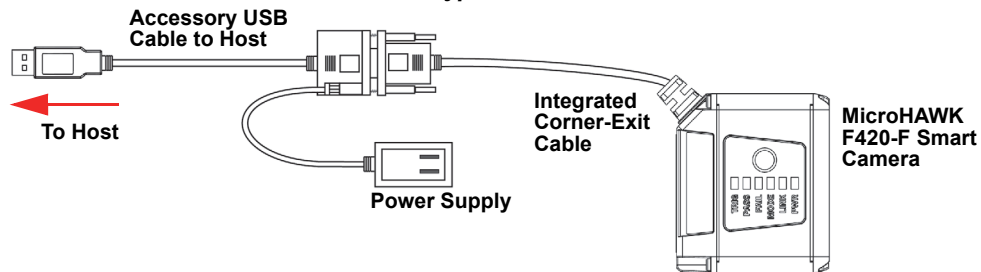

F420-F with DB15 to Ext. Power/RS-232

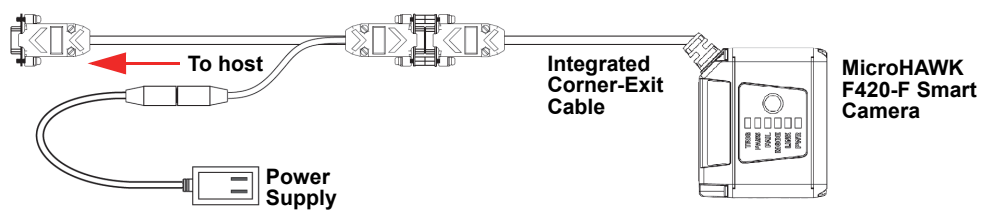

F420-F with DB15 to Ext. Power/USB, I/O

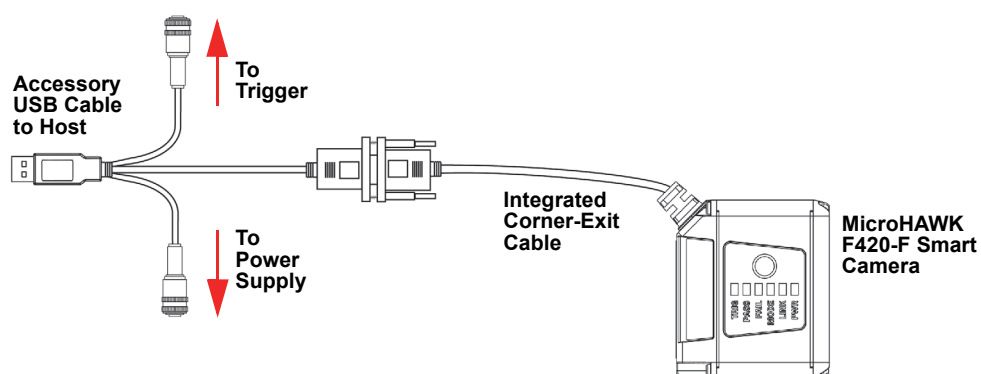

F420-F with DB15 to USB/RS-232, Triggered

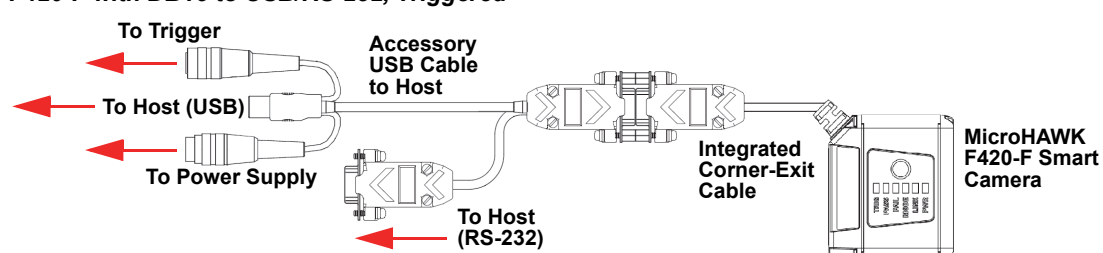

MicroHAWK F420-F Configuration Options (Continued)

F420-F with IB-131 and IC-332

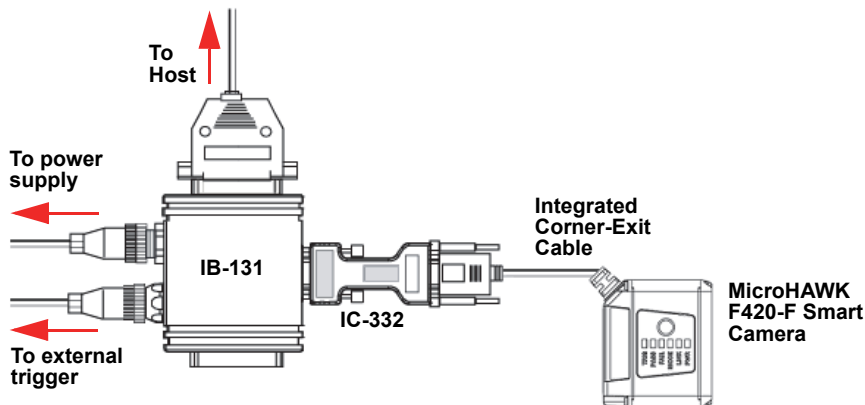

MicroHAWK F430-F Configuration Options

- Mount the camera securely in its stand (not supplied).
- Mount the camera as required by the application.
- Connect the power cable to the MicroHAWK F430-F.
- Connect the Ethernet cable to the MicroHAWK F430-F.
- Connect the Ethernet cable to the host.
- Connect the power cable into the power source.

Basic F430-F Configuration

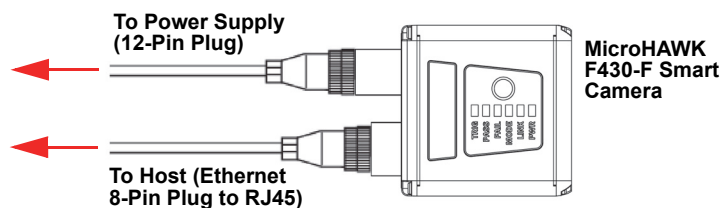

F430-F M12 12-Pin Socket to 9-Pin Socket and M12 Plug

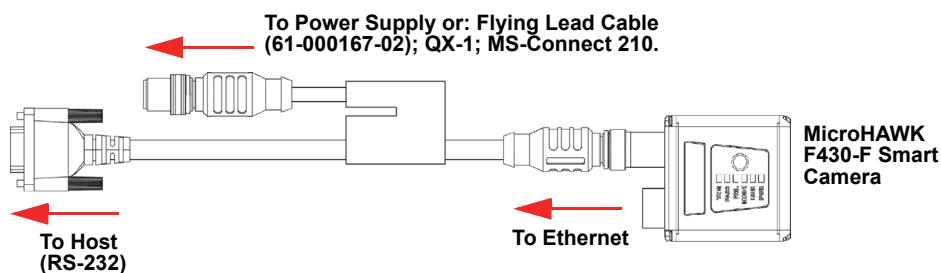

F430-F Configuration with QX-1 Interface Device

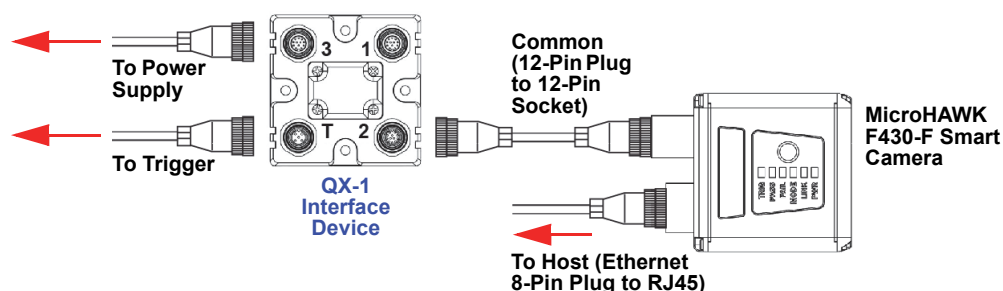

Important: See [Appendix B](#) for F320-F, F330-F, F420-F, and F430-F pin assignments.

QX-1 Interface Device

The QX-1 Interface Device (98-000103-02) simplifies the installation of MicroHAWK cameras. It is used to break out and distribute Power, Communications, and Digital I/O using standard MicroHAWK cables and accessories.

Connectors

- (1.) **Connector 3** – Power is supplied through Connector 3. Power is distributed to all other QX-1 Connectors to provide power to the camera, Photo Sensor (Trigger), and Smart Light.
- (2.) **Connector 1** – Smart Lights or a Host Serial Cable are connected to Connector 1. In the case of a Smart Light, Power and/or Power and Strobe Control are distributed to the Smart Light. In the case of the Host Serial Cable, RS-232 and Digital I/O are distributed to the DB-9 connector that can be connected to a Host.
- (3.) **Connector T** – A Photo Sensor is typically connected to Connector T. The Trigger signal is sent directly to the camera.
- (4.) **Connector 2** – The cameras are connected to Connector 2. Power, Trigger, RS-232, and all Digital I/O including the Strobe Signal are routed through this cable.

Switches

There are two switches that control how signals are routed through the QX-1 Interface Device. For the MicroHAWK, the two switches are set to the right by default, to distribute power to all connectors, and to send the Trigger signal to the camera.

QX-1 Connector View and Switch Settings

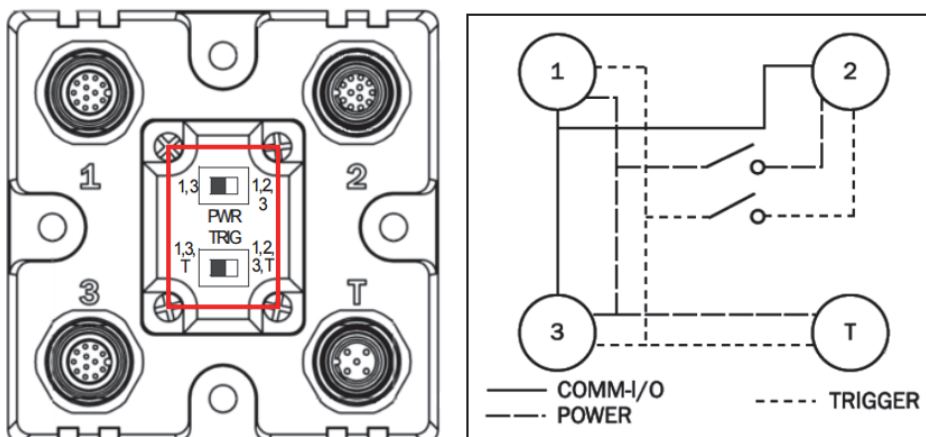

The QX-1's switches are set to the right by default for MicroHAWK use. In this configuration, communication, power, and trigger are distributed to all connectors.

Examples of Common MicroHAWK Configurations using the QX-1 Interface Device

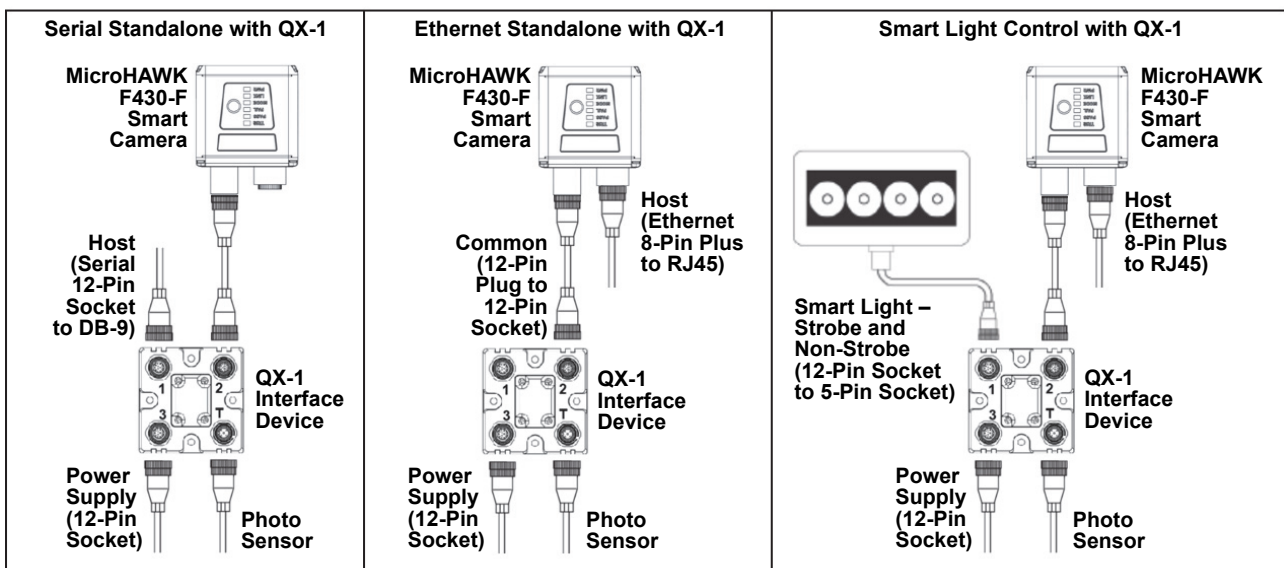

2-5 Mounting the Camera

2-5-1 Mount and Position the Camera

- 1** Position the camera at a focal distance of one inch or more from a test object.
- 2** Tip the camera relative to the object to avoid the glare of direct (specular) reflection. The case parting line should be perpendicular to the plane of the symbol by either pitching the symbol or the camera. Avoid excessive skew or pitch. Maximum skew is $\pm 30^\circ$; maximum pitch is $\pm 30^\circ$.

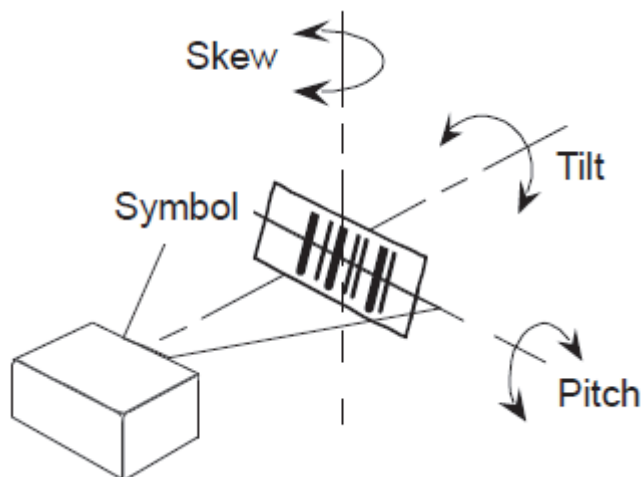

2-6 I/O Wiring

2-6-1 MicroHAWK F420-F

Direct Input / Output Diagrams

Trigger Input Example

Trigger, New Master Inputs: 3 to 24V rated, 1mA @ 5VDC

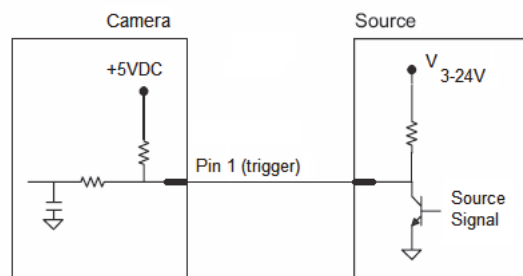

Output Examples

Outputs (1, 2, 3): 5V TTL compatible, can sink 10mA and source 2mA

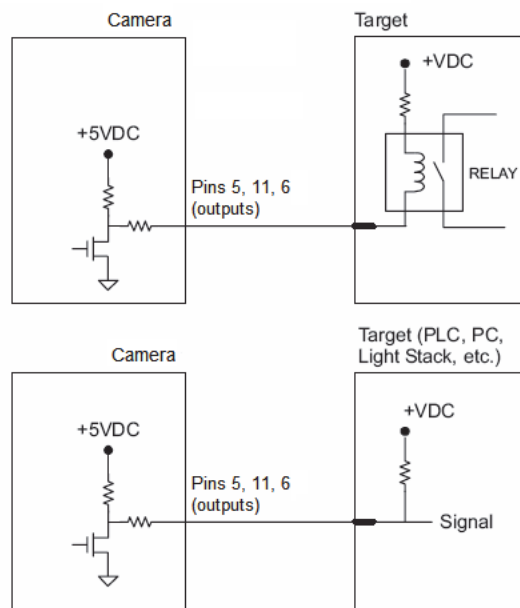

Optoisolator Trigger Inputs for IC-332

Trigger input can be fully electrically isolated from an NPN or PNP signal source.

	Minimum	Maximum
$V_{IN-HIGH}/I_{IN-HIGH}$	4.5V/3.0mA	28V/15mA
V_{IN-LOW}/I_{IN-LOW}	0V/0mA	2.0V/1mA
Pulse Width _{min}	48 μ s	

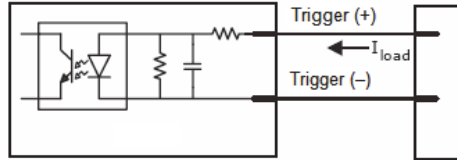

Input Examples

Fully Optoisolated

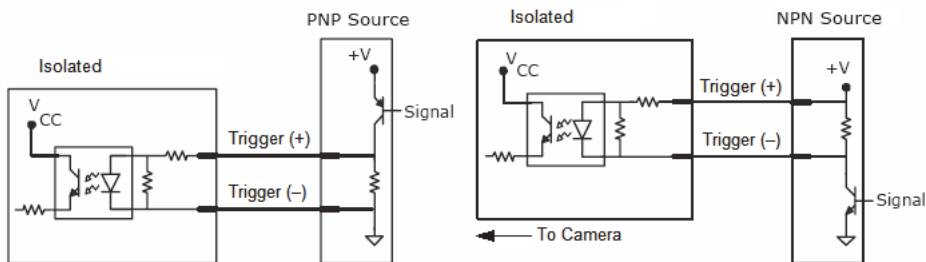

Not Optoisolated

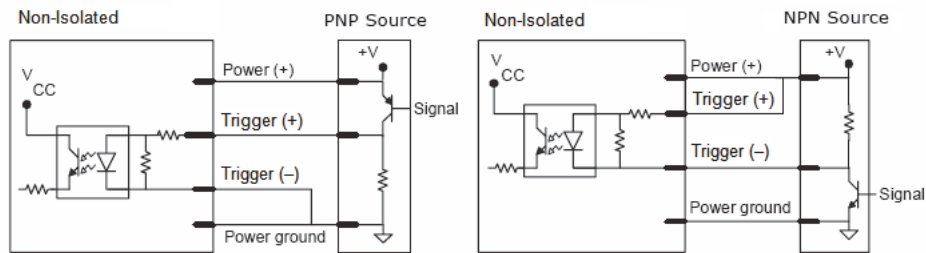

New Master Pin

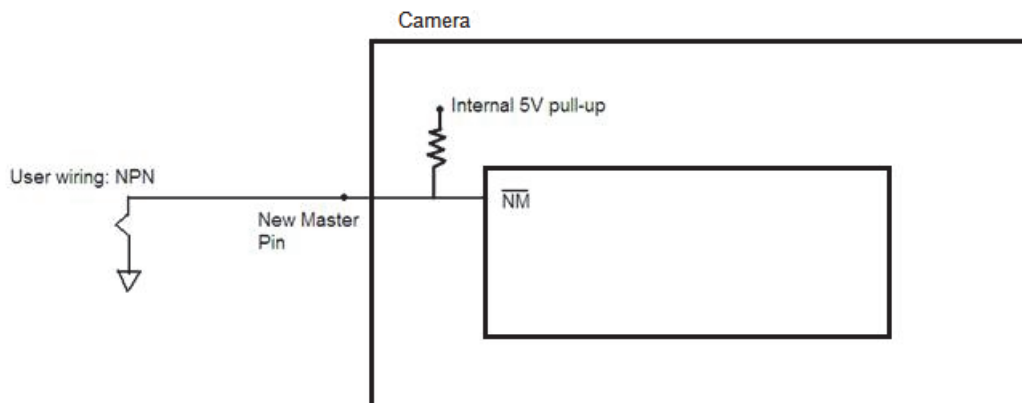

2-6-2 MicroHAWK F430-F

Optoisolated Outputs

The camera has optoisolated outputs that can transfer signals from the camera to peripherals. Outputs can be configured as either NPN or PNP, but NPN and PNP cannot be mixed in a system, because the output common is shared by all outputs.

● NPN Output for Host Input

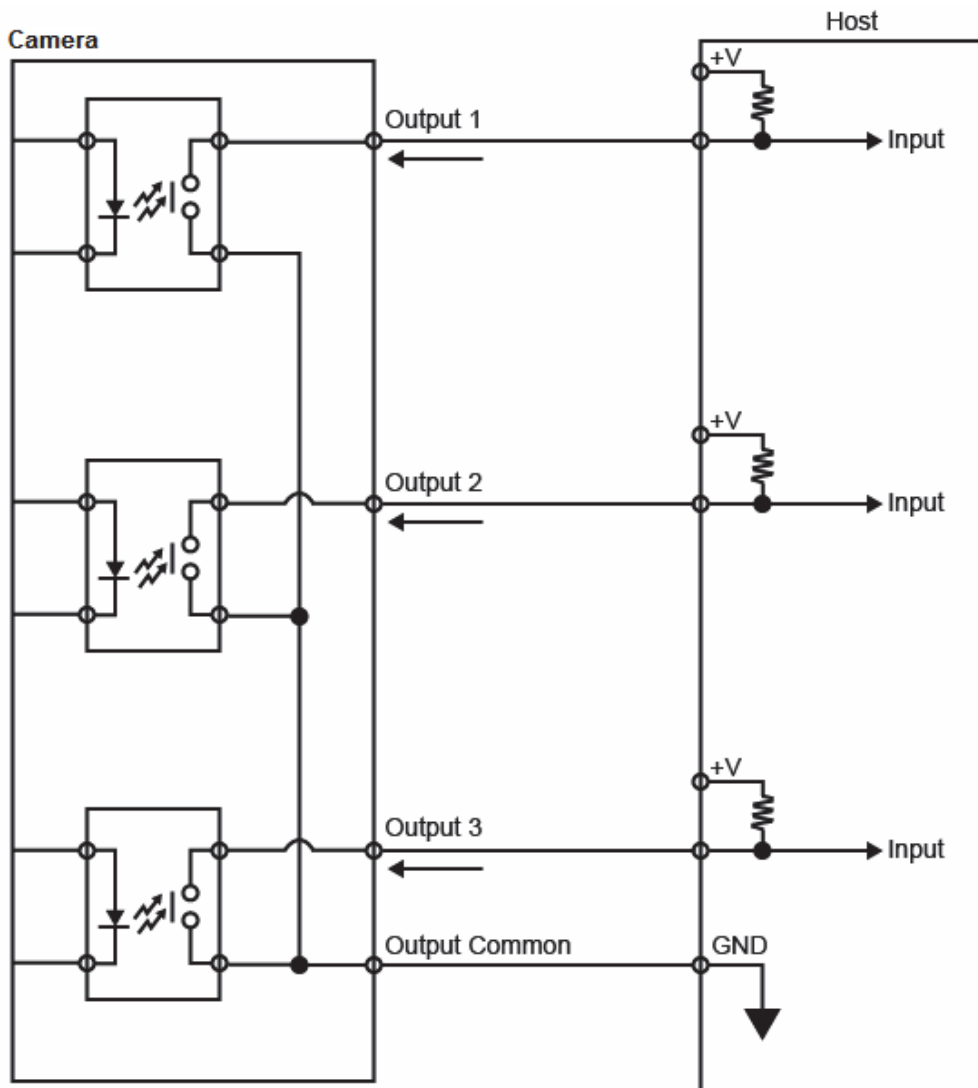

● NPN Output for External Load

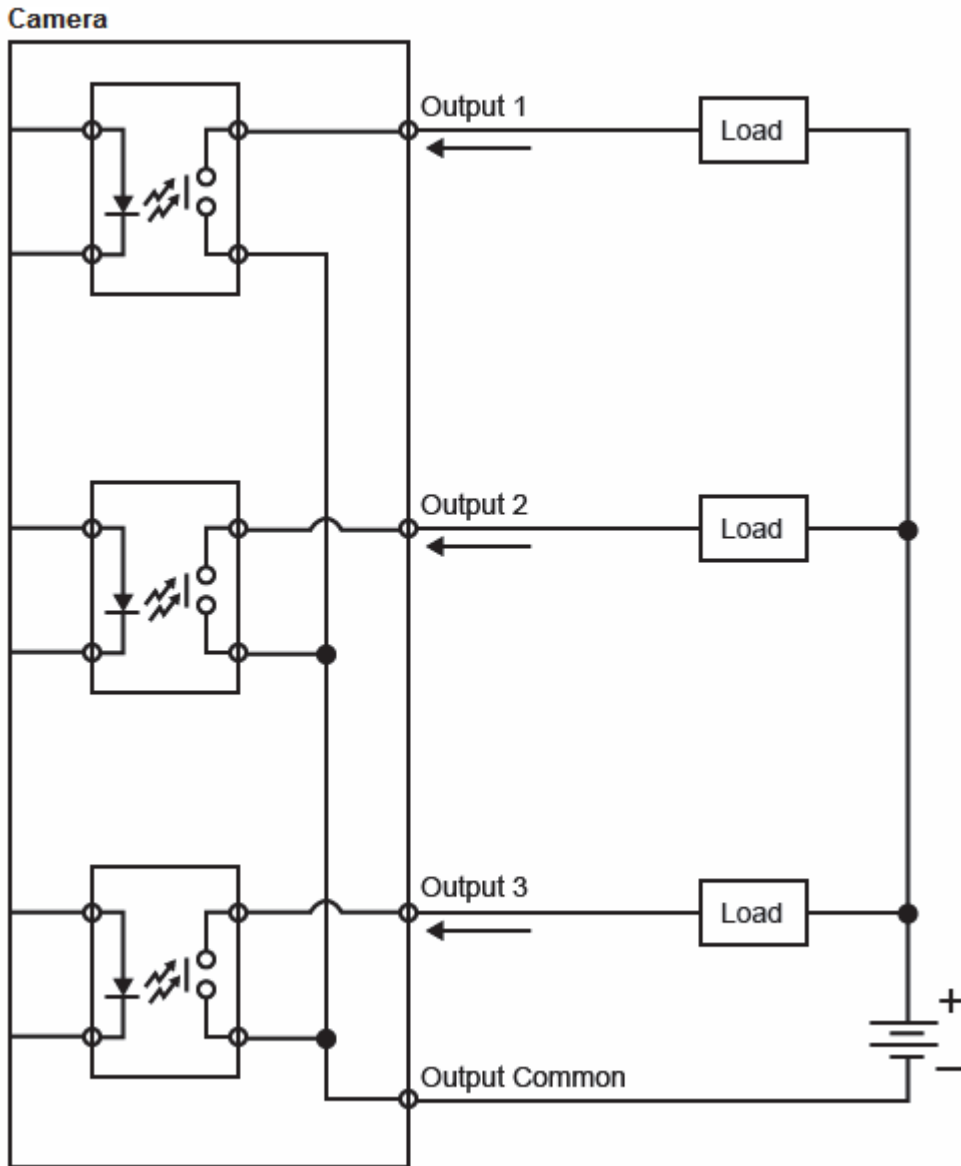

● PNP Output for Host Input

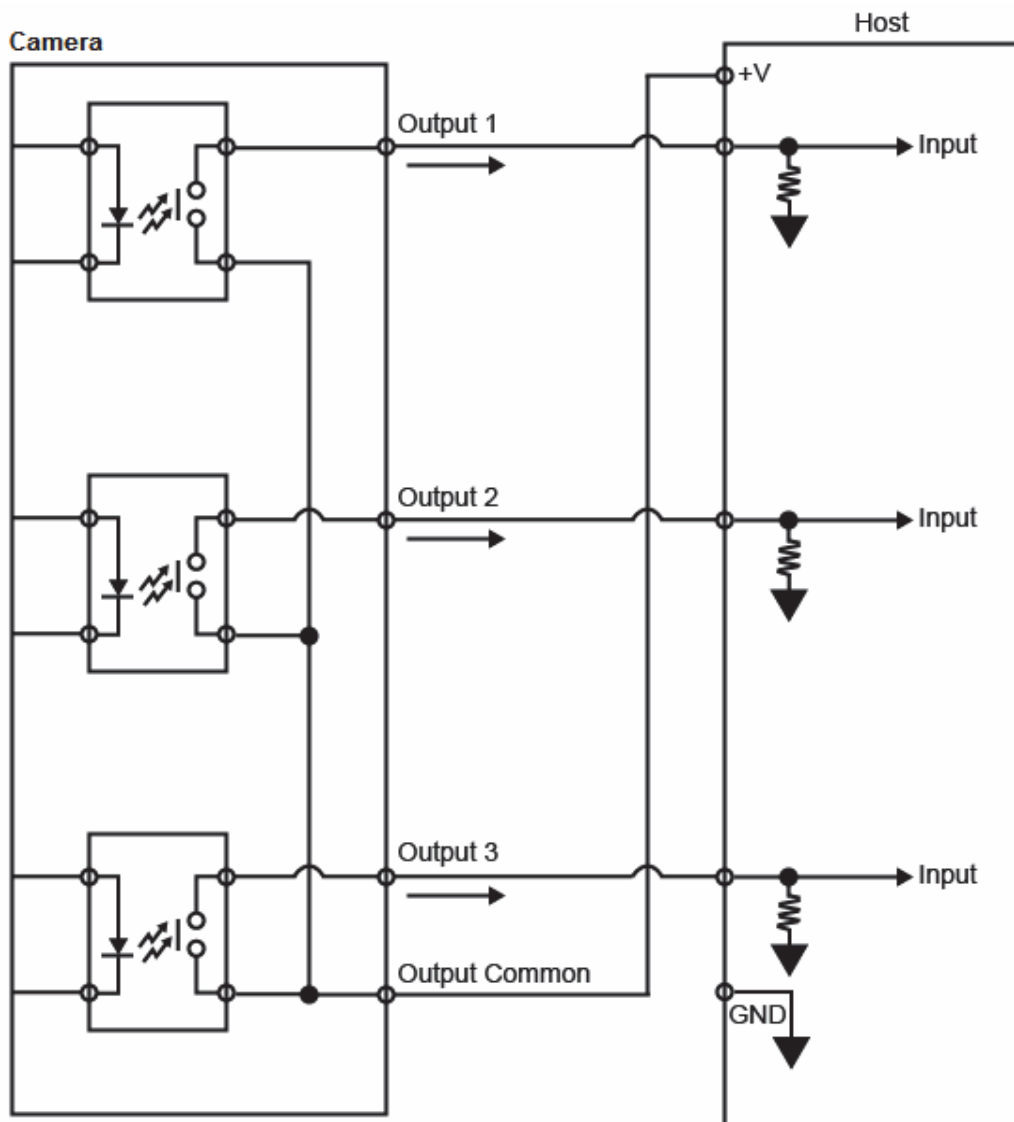

● PNP Output for External Load

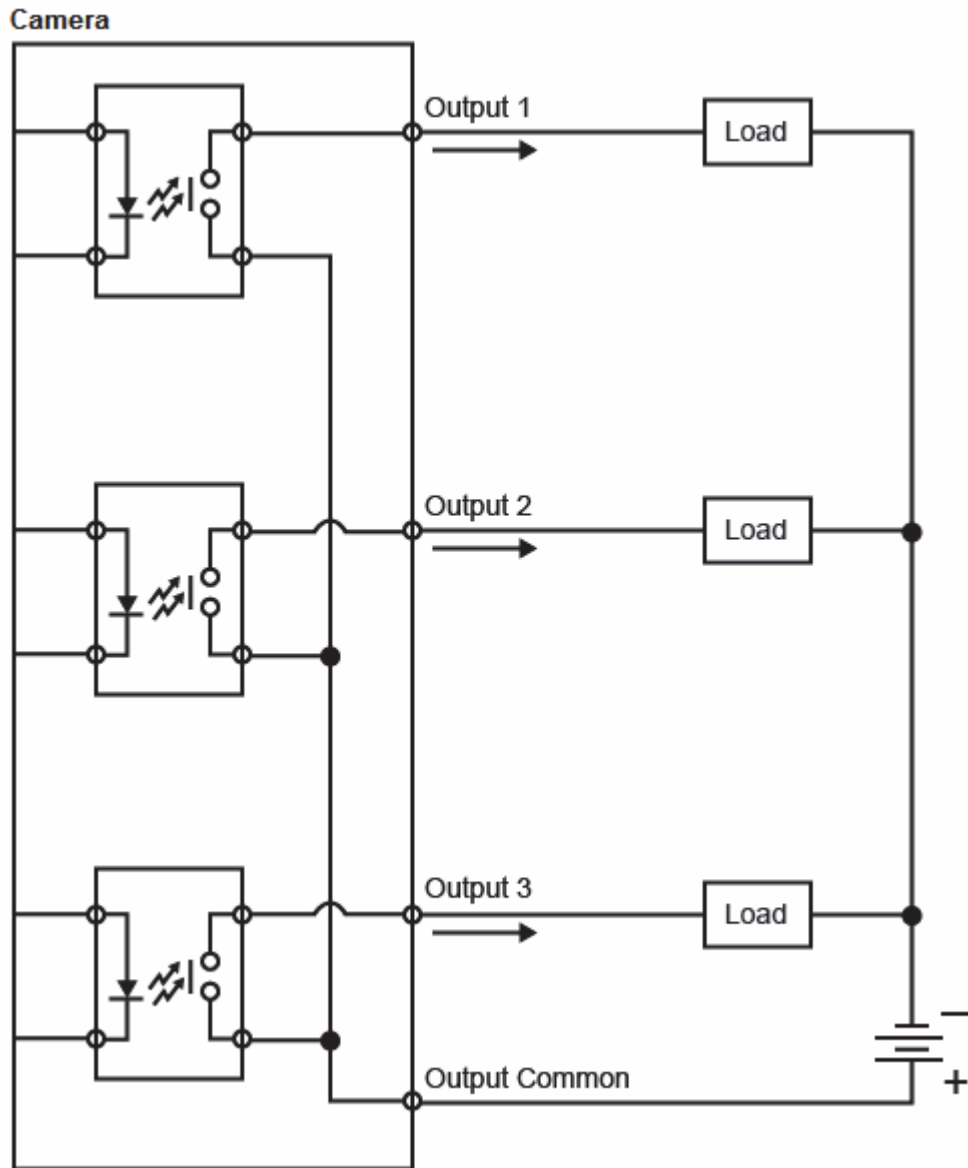

Optoisolated Inputs

● NPN Output for Host Input

All discrete inputs are optoisolated. Inputs can be configured as either NPN or PNP, but NPN and PNP cannot be mixed in a system, because the input common is shared by all inputs.

● NPN

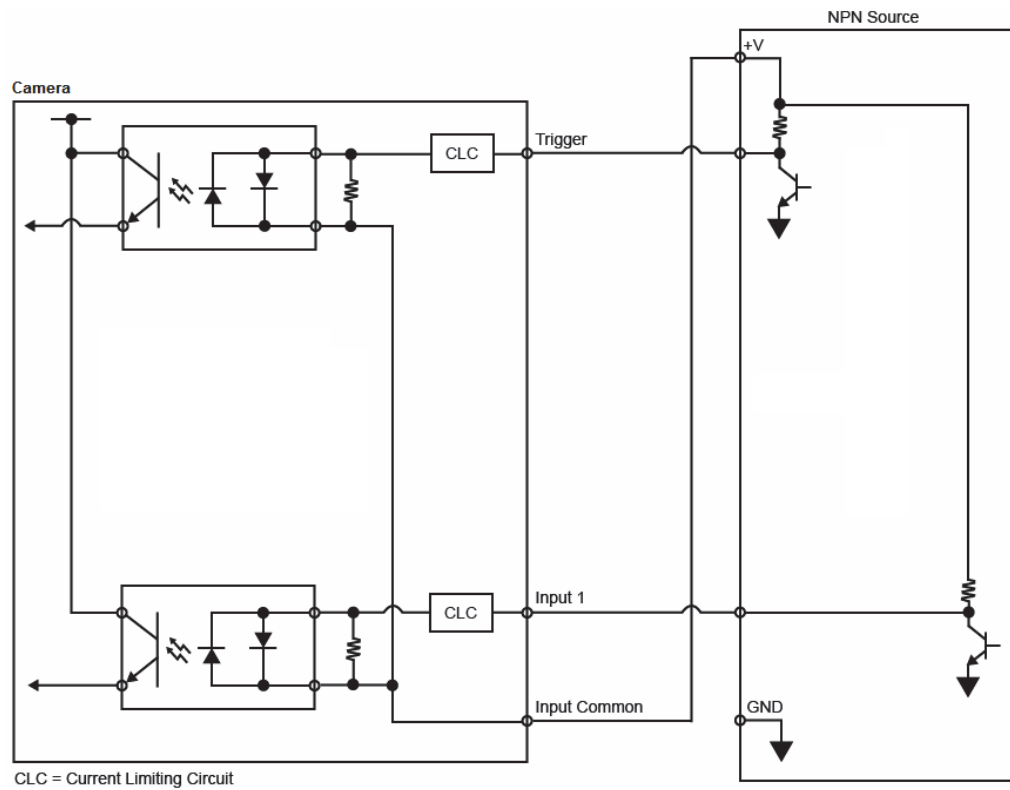

● PNP

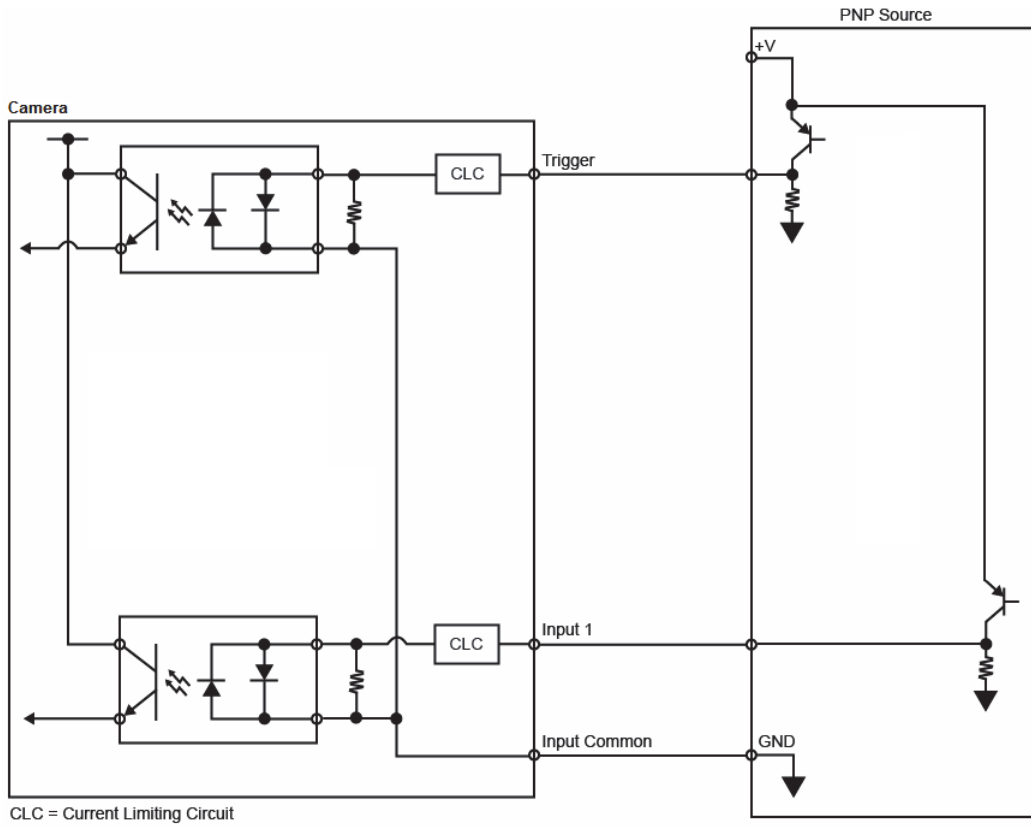

2-7 Grounding and Power

2-7-1 Ground and Shield Considerations

Proper grounding is necessary for operator safety, noise reduction, and the protection of equipment from voltage transients. Buildings, including any steelwork, all circuits, and all junction boxes must be grounded directly to an earth ground in compliance with local and national electrical codes.

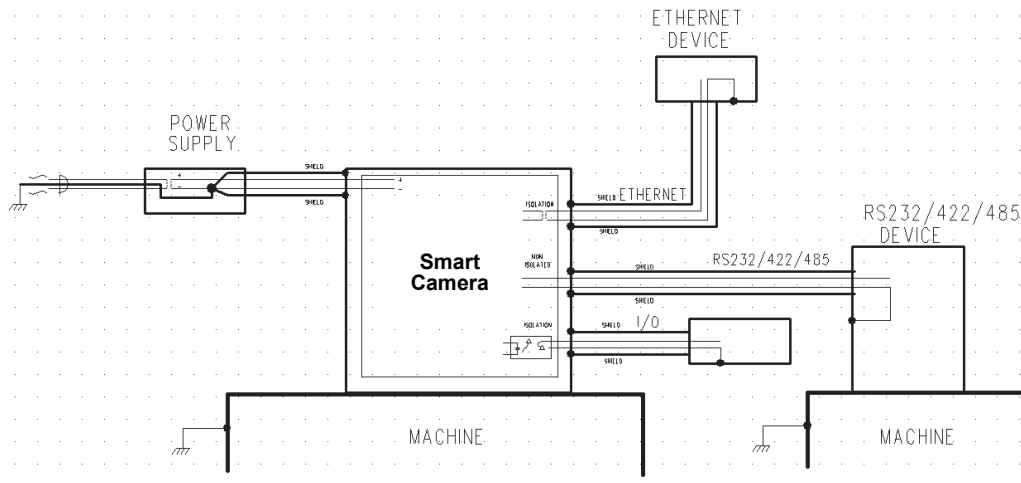

An earth ground is provided through the cable shields and chassis of the camera.

Ground Loops

Ground loops (signal degradation due to different ground potentials in communicating devices) can be eliminated or minimized by ensuring that both the host, imager, and their power supplies are connected to a common earth ground.

Expected Power and Ground Connections for Proper Operation

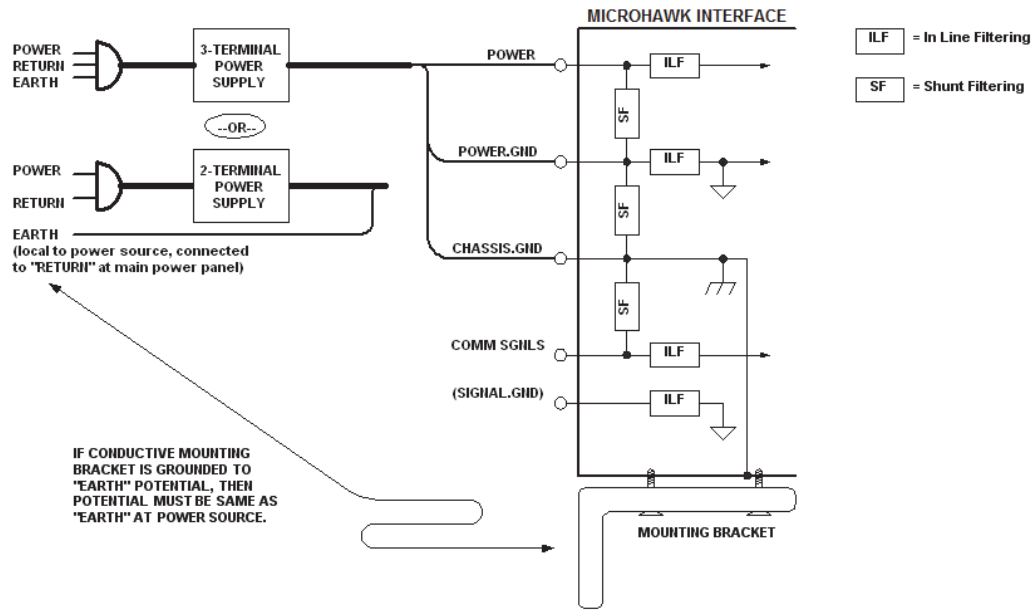

Grounding Notes

- Ensure that mounting bracket "Earth" is at the same potential as power source "Earth".
- Supply "Return" and "Earth" ground must be stable, low-impedance reference points.
- "2-Terminal Power Supply" must still provide an "Earth" connection to the imager.
- "Signal Ground" can be used for communications and/or discrete signal ground reference. It must **not** be used as Power Ground or Earth Ground.

Power Requirements

Refer to this table when determining the power requirements for your camera.

	Power Supply Voltage	Current Consumption
F320-F	5 VDC +/- 5%	450 mA at 5 VDC (max.)
F330-F	Source: 44-57 VDC IEEE802.3af POE	Max Current: 0.090 A
F420-F	5 VDC +/- 5%	650 mA at 5 VDC (max.)
F430-F	5 to 30.0 VDC, 200 mV p-p max ripple	0.18 A at 24 VDC (max.)

2-8 I/O Filtering and Debounce

Trigger Debounce is the ability of the system to accommodate switching noise on a trigger state change – a common issue with relays that have some intermittent contact while engaging.

Trigger overruns (when the vision system is triggered faster than the device can process) can be avoided by increasing the “debounce” time in the camera definition file located in the C:\Microscan\Vscape\Drivers\CamDefs directory.

The I/O Line Debounce High Time and I/O Line Debounce Low Time can be added to the file as in the example below. Debounce time is 1 ms (1,000 μ s).

Note: Although the value entered for the "I/O Line Debounce Time" is in microseconds, it will only be rounded up to a millisecond value. For example, entering the value 1001 will resolve to 2 ms; entering a value of 2800 will resolve to 3 ms.

The min value for "I/O Line Debounce Time" is 0, which disables software debounce altogether. The maximum value is 100000 (100 ms).

This is the the standard debounce as described for the trigger:

```
I/O Line Debounce High Time      1000 //usecs (default is 0)
I/O Line Debounce Low Time       1000 //usecs (default is 0)
```

The smart cameras have an I/O Line Filter Time as well:

```
I/O Line Filter High Time        100 //usecs (default is 100)
I/O Line Filter Low Time         100 //usecs (default is 100)
```

I/O Filter is the ability to ignore any signals on the I/O lines that are less that the “Filter Time” long. Sometimes, electrical interference puts spikes on the line. This feature makes it ignore them until the signal that is seen on the I/O line is longer than the filter time.

2-9 Camera Definition File Example

```
// Camera Definition File
// Version: 1.04

Camera Name          MicroHAWK 1280x960 // Name Displayed in Camdef Selection Dialog
Digitizer Type      6001                // Number associated with Trident
SXGA

Stride              1280                // Image Width
Rows                960                 // Image Height
X Offset            0                   // Image X Offset
Y Offset            0                   // Image Y Offset
Bits Per Pixel      8                   // Bits that represent Pixel Value
Pixel Type          0                   // Type of Pixel: MONOCHROME=0, COLOR_RGB=1,
COLOR_BGR=2, COLOR_BAYGR8=3, COLOR_BAYRG8=4, COLOR_BAYGB8=5, COLOR_BAYBG8=6, COLOR_HSI=7
Image Structure     1                   // Pixel Organization: Packed=1, TwoPlanes = 2, ThreePlanes = 3

Async Control       1                   // Controllable shutter time. Usually using a pulse width
specified in usecs
Usecs Per Frame     18518              // Fastest time to acquire a frame: 54 FPS
// -1 Disables timeout feature

Binning             0
Zoomed              0

// I/O Configuration
GPIO Edit Mask      0x0000
GPIO Defaults       0x0001 // 1 General Purpose Input 3 General Purpose Outputs
GPIO Count          4
GPIO Inputs         1
GPIO Outputs        3
Sensors             1                 // One input dedicated to Trigger signal
Strobes             0

Virtual I/O         2048

I/O Line Filter High Time 100          //usecs (default is 100)
I/O Line Filter Low Time  100          //usecs (default is 100)
I/O Line Debounce High Time 0          //usecs (default is 0)
I/O Line Debounce Low Time 0          //usecs (default is 0)
Sensor Trigger Delay Time 0            //usecs
Custom External Strobe Delay Time0 //usecs

// Focus & Photometry Ranges
Gain Dflt           20
Gain Min            0
Gain Max            100                // 0 to 100%
Exp Dflt            4000
Exp Min             66
Exp Max             58825              // 1/17 to 1/15,000
Focus Dflt          100                // 100 mm default
Focus Min           50
Focus Max           500                // 50 to 500 mm
```

2-10 Status Indicators

MicroHAWK F420-F and F430-F LED Indicators

The top of the MicroHAWK F420-F and F430-F has multiple LEDs that indicate different inspection, trigger, camera, communication, and power states.

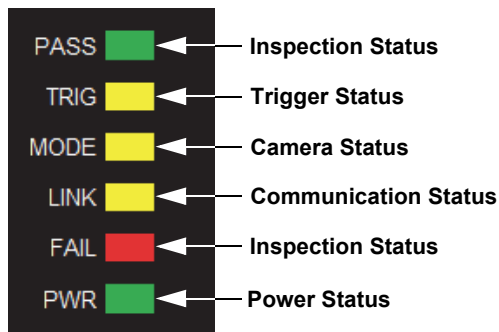

Additional Feedback from F420-F and F430-F LEDs

Green Flash – A green flash from the front of the unit indicates a successful inspection.

Blue Targeting Pattern – The blue targeting pattern from the front of the unit allows the user to center an object in the field of view.

LED	Status	Description
PASS	On	Active State (PASS)
	Off	Inactive State
TRIG	On Steady	Continuous Trigger
	Off	Waiting for Trigger Event
	Flashing On/Off	Trigger Event
MODE	On Steady	Unit Ready
	Off	Unit Not Ready
LINK	On Steady	Link Established
	Off	No Link/Activity
	Flashing On/Off	Link Established and Activity on Link
FAIL	On	Active State (FAIL)
	Off	Inactive State
PWR	On	Power On
	Off	No Power Applied to Unit

MicroHAWK F320-F and F330-F LED Power Status Indicators

The top of the MicroHAWK F320-F and F330-F has a single LED that indicates whether or not the power is on.



Additional Feedback from F320-F and F330-F LEDs

Green Flash – A green flash from the front of the unit indicates a successful inspection.

Blue Targeting Pattern – The blue targeting pattern from the front of the unit allows the user to center an object in the field of view.

LED	Status	Description
POWER	On	Power On
	Off	No Power Applied to Unit

MicroHAWK F330-F LINK and Activity LED Indicators

The back of the MicroHAWK F330-F has two LEDs that indicate LINK and Activity status.

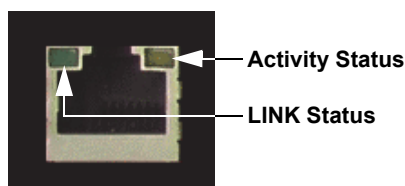

LED	Status	Description
LINK	Green On Steady	Operating as a 100 Mbps Connection
	Off	No Link Established
Activity	Amber Blinking	Activity on the Port
	Off	No Activity on the Port

3

Getting Started with AutoVISION

This section briefly describes how to set up and use a MicroHAWK Smart Camera with AutoVISION Software.

3-1	Setting Up a Job in AutoVISION	3-2
------------	---------------------------------------	------------

3-1 Setting Up a Job in AutoVISION

AutoVISION is a critical component of the camera's functionality. Designed for use with MicroHAWK Smart Cameras, AutoVISION provides an intuitive interface, step-by-step configuration, and a library of presets that allow easy setup and deployment. For more complex vision applications, the system can be upgraded from AutoVISION to Visionscape.

The MicroHAWK F430-F Smart Camera is used as an example in the following procedure.

Item	Part Number	Description
1	F430-F[XXX][Y][ZZZ]-[L][C][P]	F430-F
2	97-000012-01	Power Supply, 100-240VAC, +24VDC, M12 12-Pin Socket
3	98-000103-02	QX-1 Interface Device
4	61-000162-02	Cordset, Common, M12 12-Pin Socket (Screw-On) to M12 12-Pin Plug
5	61-000160-03	Cordset, Host, Ethernet, M12 8-Pin Plug (Screw-On) to RJ45, 1 m
6	99-9000016-01	Photo Sensor, M12 4-Pin Plug, NPN, Dark On or Light On (Selectable), 2 m

1. Configure Hardware

- Mount the camera as required by the application.
- Connect the Ethernet cable from "B" on the camera to the network.
- Connect the power supply to "3" on the QX-1.
- Connect the photo sensor to "T" on the QX-1.
- Connect the "Common" cable to "2" on the QX-1 and "A" on the camera.
- Plug in the power supply.

F430-F with QX-1 Interface Device

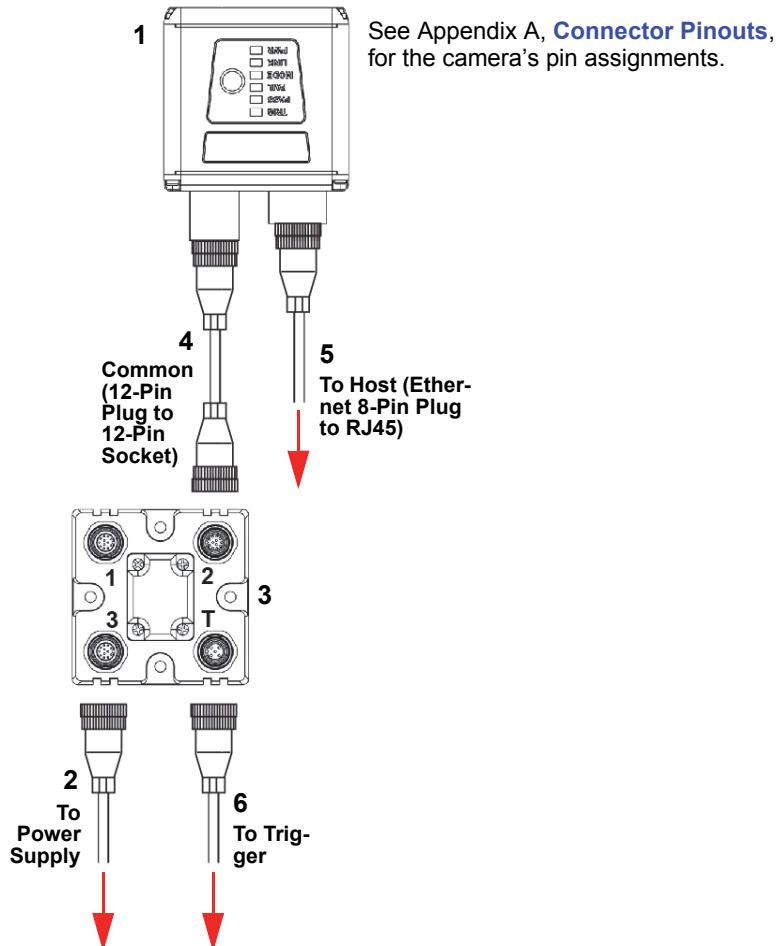

2. Select in Connect View; Create a Job; Adjust Camera Settings

AutoVISION's **Connect** view allows you to select your device and configure its settings, and to create a new job. The **Select Device** drop down menu provides a list of available devices. Hover the mouse over a device to see its details.

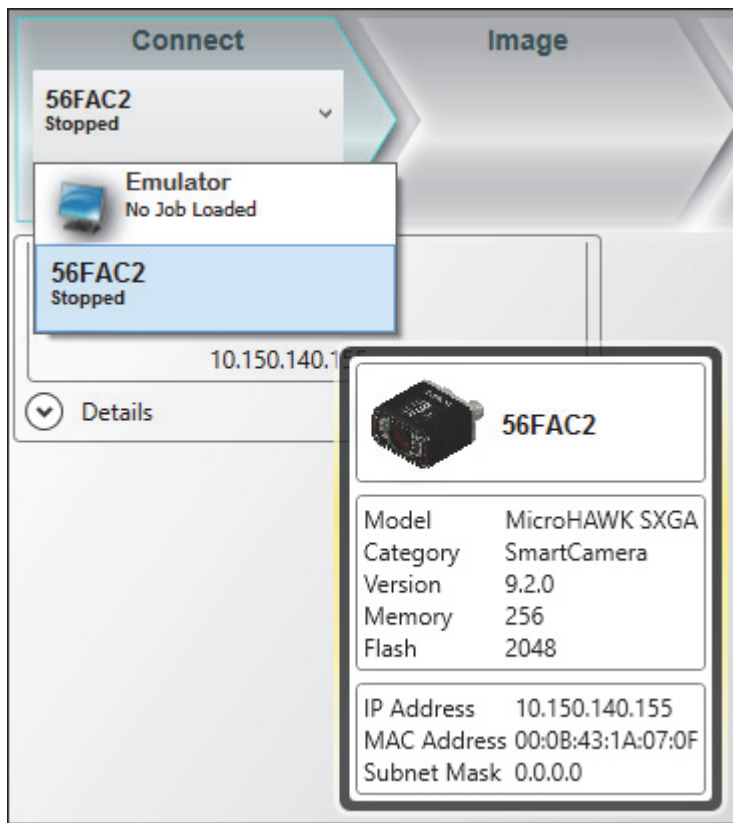

Click the lock icon to take control of the camera. When you have control of the camera, the **Modify** button will appear beneath the camera settings. Click the Modify button to adjust camera settings.

Note: If you are using a MicroHAWK F420-F with a USB cable, the driver has already configured your PC address. If you are using a MicroHAWK F430-F, you must set the PC to the same IP range as the default IP address. Default IP address: **192.168.188.2**. Set the PC to the same IP range (example: **192.168.188.100**).

The screenshot shows the 'Connect' view of the AutoVISION software. On the left, a camera named '56FAC2' is listed as 'Stopped'. Below this, a 'Details' section provides technical specifications for the 'MicroHAWK SXGA SmartCamera', including its version (9.2.0.3027), memory (256 MB), and flash (2048 MB). A network configuration table is also present, showing an IP address of 10.150.140.155 and other network parameters. On the right, a 'No job is loaded' message is displayed above three buttons: 'Create a New Job', 'Load a Job', and 'Upload Current Job from Device'. A callout box points to the 'Details' section, instructing users to modify camera settings there. Another callout box points to the job management buttons, instructing users to create, load, or upload jobs using these buttons.

Model	MicroHAWK SXGA
Category	SmartCamera
Version	9.2.0.3027
Memory	256 MB
Flash	2048 MB

IP Address	10.150.140.155
MAC Address	00:0B:43:1A:07:0F
Subnet Mask	0.0.0.0
Gateway	0.0.0.0
DHCP	Enabled
Number of serial TCP ports	4
Starting serial TCP Port	49211

Industrial Protocol	EtherNet/IP
Serial Port	RS232-1
Baud Rate	115200
Data Bits	8
Parity	None
Stop Bits	1
Flow Control	None

Auto Button	True
-------------	------

Important: When modifying camera settings, you will need to enter a username and password for the camera if a password has been defined.

Once you have selected your camera, adjusted its settings, and created a new job, you will move to the **Image** view. This view allows you to **Auto Calibrate** the camera, and to manually adjust the camera's Exposure, Gain, and Focus, and also to set the Lighting Mode (On, Off, or Strobe).

The screenshot shows the 'Image' view of the AutoVISION software. The main window displays a camera feed of a red background with a grid. Overlaid on the feed are a QR code, a barcode, and the text 'MicroHAWK + AutoVISION MACHINE VISION SIMPLIFIED'. Below the QR code, the text 'GTIN 12345678901231', 'LOT 123456', and 'DATE 2016-09-15' is visible. On the right side, there is a control panel with various settings: 'Image Size' (752 x 480), 'Dynamic Range' (Excellent), 'Histogram', 'Acquire images from Camera' button, 'Exposure' (500 usec), 'Gain' (.5), 'Focus' (400 in/100), and 'Lighting Mode' (Strobe). The bottom status bar shows 'MicroHAWK187172 | 10.20.1.67 | MicroHAWK WVGA | 255 | 395,475'.

3. Edit the Job in AutoVISION

After you have created a new job, loaded a job from your PC, or uploaded a job from the camera, you will proceed to the **Edit** view to refine your machine vision job. The Camera parameters below the captured image allow you to set Gain, Exposure, Focus, Trigger, and Lighting. Inspection Outputs options allow you to connect your job to the outside world. This is also the view where you can add multiple tools to the job. The tool icons are located above the main view area.

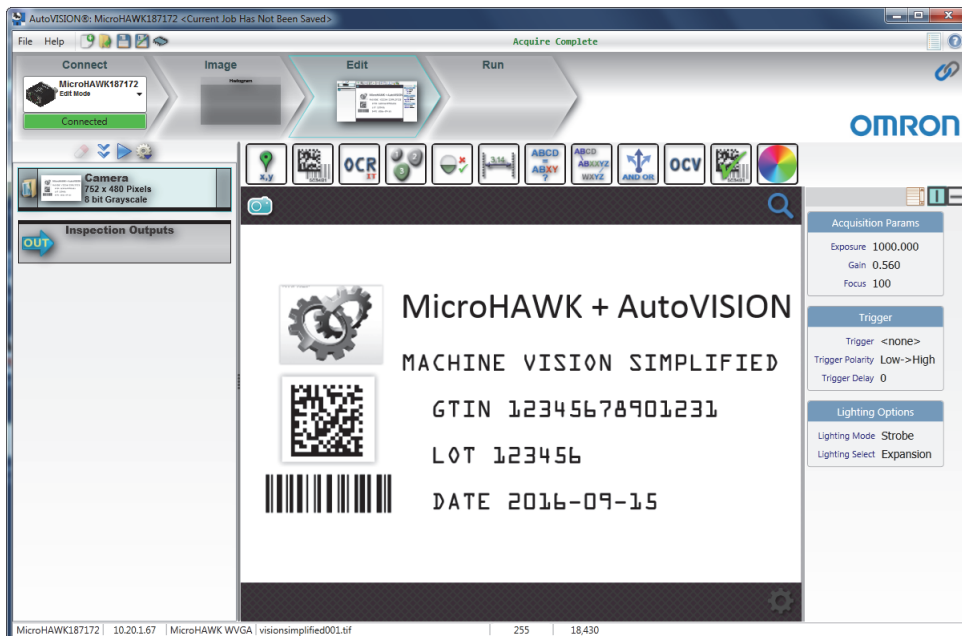

3

4. Run the Job in AutoVISION

Going to the **Run** view will automatically download your job to the camera and start it running.

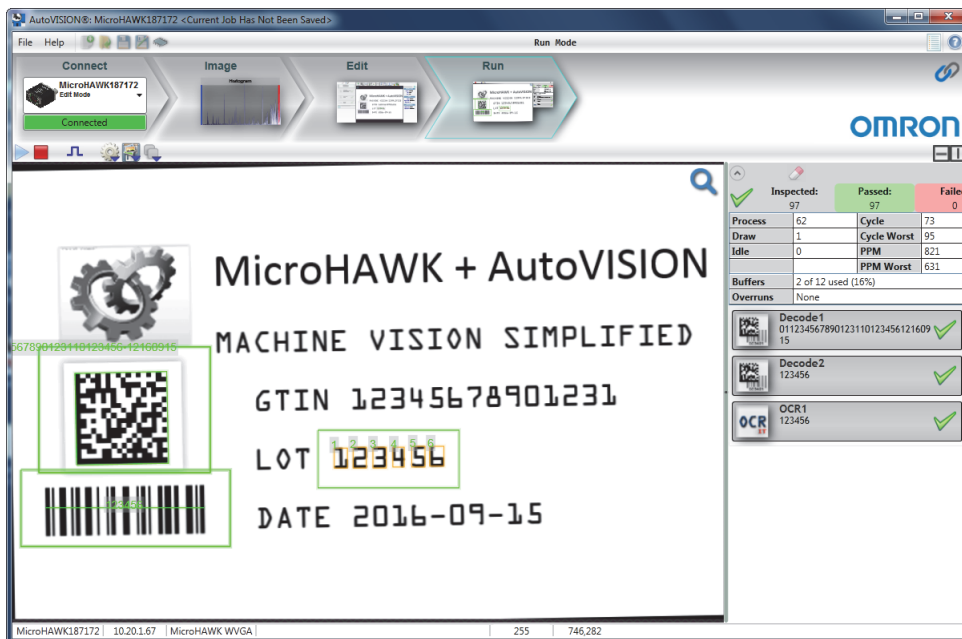

5. Save the Job

Click the **Save to Camera** icon on the **File** menu bar to save the job to the camera.



4

Optics and Lighting

This section describes the optical and illumination characteristics of MicroHAWK F320-F, F330-F, F420-F, and F430-F Smart Cameras.

4

4-1 Optics	4-2
4-2 MicroHAWK Illumination	4-4
4-3 Machine Vision Lighting Principles	4-5
4-4 MicroHAWK F430-F External Illumination Control and Wiring	4-6

4-1 Optics

The monochrome and color versions of the MicroHAWK F320-F, F330-F, F420-F, and F430-F have a built-in CMOS sensor, available in **Standard Density**, **High Density**, and **Ultra-High Density**.

Important: UHD Fixed Focus is only available in **64 mm** and **400 mm** distances.

UHD Autofocus is only available for **SXGA MicroHAWK** F320-F, F330-F, F420-F, and F430-F cameras.

4-1-1 Sensor Table

	Pixels (H x V)	Shutter	Frames per Second
WVGA	752 x 480, 0.3 MP, Mono	Global	52 fps
SXGA	1280 x 960, 1.2 MP, Mono	Global	40 fps
QSXGA	2592 x 1944, 5 MP, Color	Rolling	5 fps

4-1-2 MicroHAWK Field of View Charts

Fixed Focus Field of View (mm) – Wide Lens

Distance (mm)	0.3 MP		1.2 MP		5 MP	
	Width	Height	Width	Height	Width	Height
50	49	32	53	39	50	38
81	76	49	81	61	78	58
102	95	60	101	75	96	72
190	171	109	182	136	174	130
300	266	170	283	213	271	202

Fixed Focus Field of View (mm) – Medium Lens

Distance (mm)	0.3 MP		1.2 MP		5 MP	
	Width	Height	Width	Height	Width	Height
50	34	22	36	27	35	26
81	53	34	56	42	54	40
102	66	42	70	52	67	50
190	119	76	126	95	121	90
300	185	118	196	147	188	140

Fixed Focus Field of View (mm) – Narrow Lens

Distance (mm)	1.2 MP	
	Width	Height
64	21	15
400	118	88

Autofocus Field of View (mm) – Wide Lens

Distance (mm)	0.3 MP		1.2 MP		5 MP	
	Width	Height	Width	Height	Width	Height
50	51	33	55	41	52	39
100	97	62	103	77	98	73
150	142	90	151	113	144	107
200	187	119	199	149	190	142
250	232	148	247	185	236	176
300	277	177	295	221	282	210

Autofocus Field of View (mm) – Medium Lens

Distance (mm)	0.3 MP		1.2 MP		5 MP	
	Width	Height	Width	Height	Width	Height
50	33	21	36	27	34	25
100	63	40	67	50	64	48
150	92	59	98	73	94	70
200	121	77	129	97	123	92
250	151	96	160	120	153	114
300	180	115	191	144	183	136

Autofocus Field of View (mm) – Narrow Lens

Distance (mm)	1.2 MP	
	Width	Height
50	16	12
100	31	23
150	45	34

Long Range Autofocus Field of View (mm)

Distance (mm)	1.2 MP	
	Width	Height
75	24	18
100	31	23
200	60	45
300	89	67
400	118	88
500	147	110
600	176	132
700	204	153
800	233	175
900	262	197
1000	291	218
1200	349	262
1300	378	283
1400	407	305
1500	436	327

4-2 MicroHAWK Illumination



- **F420-F and F430-F Inner LEDs:** 4 white, 4 red (625 nm nominal).
- **F420-F and F430-F Outer LEDs:** 8 high-output white or red (617 nm nominal).
- **F420-F and F430-F** have both inner and outer LEDs. Options are also available for IR and blue outer LEDs.
- **F320-F and F330-F** only have inner LEDs.

4-2-1 LED Modules

Description	Left P/N	Right P/N	LED P/N	Wavelength
Expansion, Red	43-9500055-01	43-9500056-01	LA E65F-CAEB-24-1	617 nm
Expansion, White	43-9500055-02	43-9500056-02	NFSW036BLT b3-b6/P9-P12	N/A
Expansion, IR	43-9500055-03	43-9500056-03	SFH 4259S	850 nm
Expansion, Blue	43-9500055-04	43-9500056-04	LB E63C-T2V2-35-34	469 nm

4-2-2 Lighting Mode Table

Lighting Mode	Inner LEDs	Outer LEDs	Off	On	Strobe	Power Strobe Inner LEDs	Power Strobe Outer LEDs	External Strobe
Engine USB Power	Yes	No	Yes	Yes	Yes	No	N/A	No
Engine External Power	Yes	No	Yes	Yes	Yes	No	N/A	Yes
V320-F / F320-F USB Power	Yes	No	Yes	Yes	Yes	No	N/A	Yes
V320-F / F320-F External Power	Yes	No	Yes	Yes	Yes	No	N/A	Yes
V330-F / F330-F	Yes	No	Yes	Yes	Yes	No	N/A	No
V420-F / F420-F USB Power	Yes	Yes	Yes	Yes	Yes	No	No	Yes
V420-F / F420-F External Power	Yes	Yes	Yes	Yes	Yes	No	Yes	Yes
V430-F / F430-F (Standard Type)	Yes	Yes	Yes	Yes	Yes	No	Yes	Yes
V430-F / F430-F (Ring Type)	N/A	Yes	Yes	Yes	Yes	No	Yes	Yes

4-3 Machine Vision Lighting Principles

Proper lighting is critical to the success of a machine vision application. The smart camera features integrated lighting (built-in red LEDs for monochrome sensors and white LEDs for color sensors). Depending on the requirements of your application, you may also need external lighting from Omron Microscan's NERLITE family of machine vision lighting products.

Consider the following when setting up your application:

- Is the surface of the object flat, slightly bumpy, or very bumpy?
- Is the surface matte or shiny?
- Is the object curved or flat?
- What is the color of the object or area being inspected?
- Is the object moving or stationary?

Machine vision lighting should maximize contrast of the areas or features being inspected while minimizing the contrast of everything else.



Before Correct Lighting

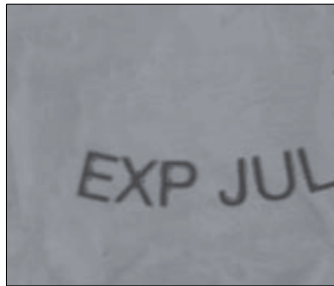

**After Correct Lighting with
a NERLITE Illuminator**

4-4 MicroHAWK F430-F External Illumination Control and Wiring

The MicroHAWK F430-F Smart Camera supports external lighting with Omron Microscan's **NERLITE Smart Series Illuminators**. The diagrams below demonstrate how cameras and lights can be configured. The light is controlled with the **Lighting** control in **AutoVISION Software's Camera** configuration settings.

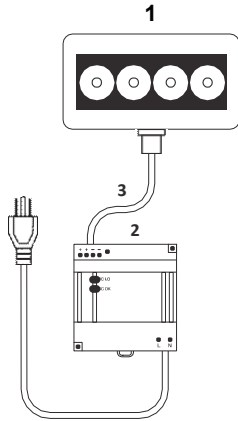

Figure A
MAX Series Illuminator
with Power Supply

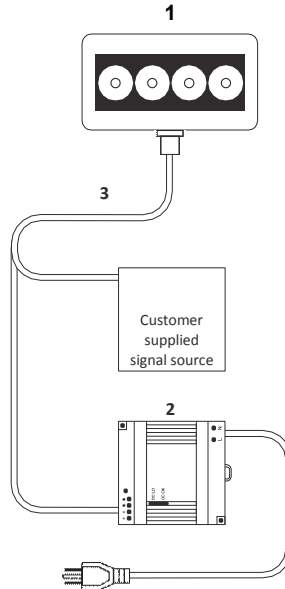

Figure B
MAX Series Illuminator
with Customer-Supplied
Dimming or On/Off
Signal Source

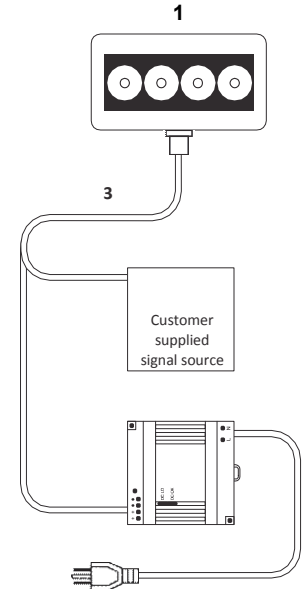

Figure C
MAX Series Illuminator with
Customer-Supplied Strobe
Trigger Signal Source

Item	Description	Part Number
1	MAX Series Lights	NER-011660XXXG
2	Power Supply DSP100 24VDC 4.2A DIN Mount	97-000006-01
	Power Supply DSP60 24VDC 2.5A DIN Mount	NER-011504100
3	Cable, 5P M12 Socket To Flying Leads, 3M	61-000186-01
	Cable, 5P M12 Socket To Flying Leads, 5M	61-000187-01
4	Cable, 5P M12 Plug To 5P M12 Socket, 1M	61-000184-01
	Cable, 5P M12 Plug To 5P M12 Socket, 3M	61-000185-01
5	Cable, Power Smart Series to QX-1	61-000204-01

QX-1 Interface

In **Strobe Mode**, the external illuminator is strobed with the exposure of the camera to maximize light for the short exposure times needed in dynamic applications.

ON/OFF allows the external illuminator to be enabled and disabled using the MicroHAWK F430-F's I/O.

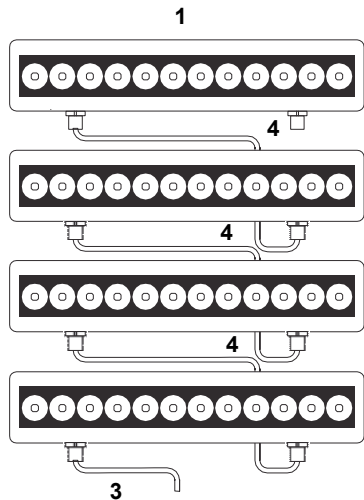

Figure D

MAX Series Illuminators in a daisy chain configuration. See Figures A, B, or C for the correct power supply and signal connections for your application.

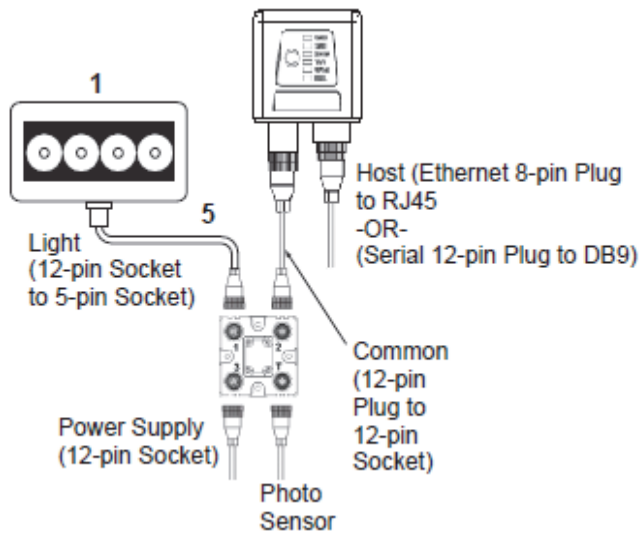

Figure E

MAX Series Illuminator with a QX-1 Interface Device.

Warning: Figure E is not compatible with daisy chain configuration. Attempting to power more than one MAX Series Illuminator with the QX-1 will exceed the QX-1's current capacity.

Item	Operation	Cable
1	Strobe	61-000218-01, Smart Series-to-QX-1, Strobe, NPN
2	ON/OFF	61-000207-01, Smart Series-to-QX-1, ON/OFF
3	Continuous ON	61-000204-01, Smart Series-to-QX-1, Continuous

4-4-1 Wiring for Strobe Illumination (NPN)

Warning: Contact between Pin 5 (gray wire) and any ground or voltage source less than or equal to 3.5 VDC may cause erratic operation in this configuration. Contact between Pin 5 (gray wire) and any voltage source greater than 3.5VDC will damage the Illuminator.

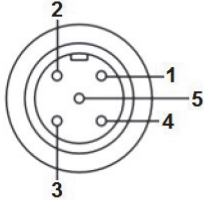

Smart Series Illuminator Connector

Smart Series Illuminator	
Pin	Signal Name
1	+24VDC
2	Trigger -
3	DC Ground
4	Trigger +
5	Dim

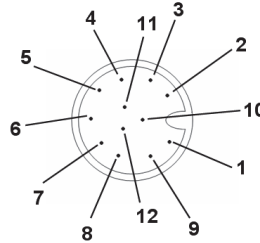

F430-F Connector A

(Connector A)	
Pin	Signal Name
2	Power
6	Output 3
7 and 12	Ground and Output Common
2	Power
No Connection*	N/A

Insulate Pin 5 (Gray Wire)

4-4-2 Wiring for Strobe Illumination (PNP)

Warning: Contact between Pin 5 (gray wire) and any ground or voltage source less than or equal to 3.5 VDC may cause erratic operation in this configuration. Contact between Pin 5 (gray wire) and any voltage source greater than 3.5 VDC will damage the Illuminator.

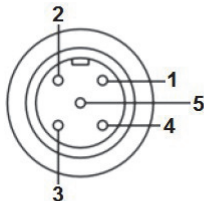

Smart Series Illuminator Connector

Smart Series Illuminator	
Pin	Signal Name
1	+24VDC
2	Trigger -
3	DC Ground
4	Trigger +
5	Dim

to
to
to
to
to

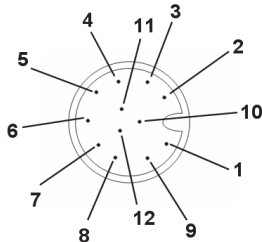

F430-F Connector A

(Connector A)	
Pin	Signal Name
2 and 12	Power and Output Common
7	Ground
7	Ground
6	Output 3
No Connection*	N/A

Insulate Pin 5 (Gray Wire)

4-4-3 Wiring for ON/OFF Illumination (NPN Only)

Warning: Contact between Pin 5 (gray wire) and any voltage source greater than 3.5 VDC will damage the Illuminator.

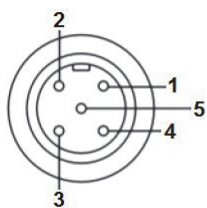

Smart Series Illuminator Connector

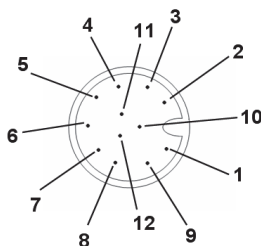

F430-F Connector A

Smart Series Illuminator	
Pin	Signal Name
1	+24VDC
2	Trigger -
3	DC Ground
4	Trigger +
5	Dim

to
to
to
to
to

(Connector A)	
Pin	Signal Name
	Power
7 and 12	Ground and Output Common
7 and 12	Ground and Output Common
2	Power
6	Output 3

Insulate Pin 5 (Gray Wire)

4-4-4 Wiring for Continuous Illumination

Warning: Contact between Pin 5 (gray wire) and any ground or voltage source less than or equal to 3.5VDC may cause erratic operation in this configuration. Contact between Pin 5 (gray wire) and any voltage source greater than 3.5VDC will damage the illuminator.

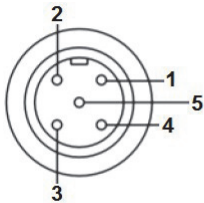

Smart Series Illuminator Connector

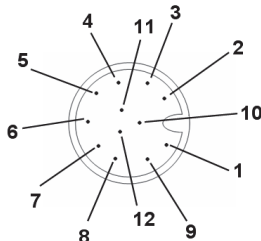

F430-F/F420-F Connector A

Smart Series Illuminator	
Pin	Signal Name
1	+24VDC
2	Trigger -
3	DC Ground
4	Trigger +
5	Dim

to
to
to
to
to

(Connector A)	
Pin	Signal Name
2	Power
7	Ground
7	Ground
2	Power
No Connection*	N/A

Insulate Pin 5 (Gray Wire)

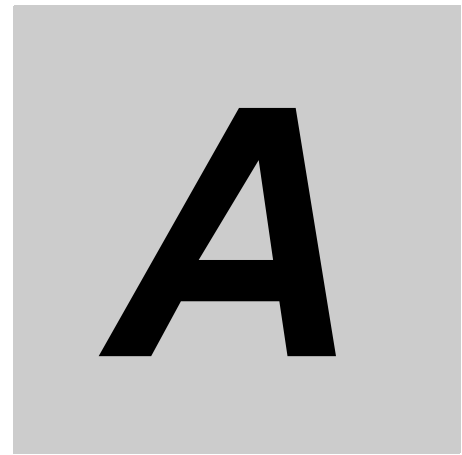

Appendix A - Connector Pinouts

This section contains information about the MicroHAWK, F320-F, F330-F, F420-F, and F430-F Smart Camera's connectors and pin assignments.

A-1	MicroHAWK F320-F Connector	A-2
A-2	MicroHAWK F330-F Connector	A-3
A-3	MicroHAWK F420-F Connector	A-4
A-4	MicroHAWK F430-F Connector	A-5

A-1 MicroHAWK F320-F Connector

A-1-1 RJ50 Socket, 10 Pins

J1: Connector Type: RJ-50 Female, 10 Pins

Pin Number	Signal Name	Description
1	D-	USB Differential Signal, Data -
2	D+	USB Differential Signal, Data +
3	USB VBUS	USB Host Power Source
4	GND	Ground
5	RS-232 RX	RS-232 Receive (To ID-22)
6	RS-232 TX	RS-232 Transmit (From ID-22)
7	+5V	External Power Source
8	GND	Ground
9	Output1	Output Strobe
10	Trigger	Input Trigger

A-2 MicroHAWK F330-F Connector

A-2-1 RJ45 Connector, 8 Pins

PINS on Switch	10/100 DC on Spares (mode B)	10/100 Mixed DC & Data (mode A)
Pin 1	Rx +	Rx + DC +
Pin 2	Rx -	Rx - DC +
Pin 3	Tx +	Tx + DC -
Pin 4	DC +	unused
Pin 5	DC +	unused
Pin 6	Tx -	Tx - DC -
Pin 7	DC -	unused
Pin 8	DC -	unused

A

A-3 MicroHAWK F420-F Connector

A-3-1 High-Density 15-Pin D-Sub Socket

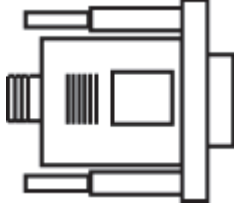

Note: An accessory cable is required between the F420-F's 15-pin corner-exit cable and the host's USB port.

Pin	Function
1	+5VDC
2	TX232
3	RX232
4	GND
5	D+
6	N/C
7	Output 1+
8	Default+
9	Trigger+
10	D-
11	Output 3+
12	New Master+
13	N/C
14	Output 2+
15	Vbus

A-4 MicroHAWK F430-F Connector

A-4-1 Connector A - M12 12-Pin Plug - Power, I/O, and Serial

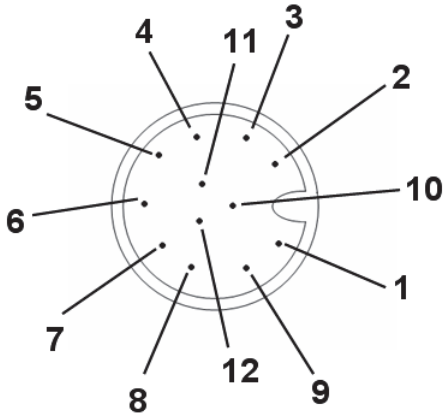

Pin	Function
1	Trigger
2	Power
3	Default
4	New Master
5	Output 1
6	Output 3
7	Ground
8	Input Common
9	RS-232 (Host) RxD
10	RS-232 (Host) TxD
11	Output 2
12	Output Common

A

A-4-2 Connector B - M12 8-Pin Socket - Ethernet

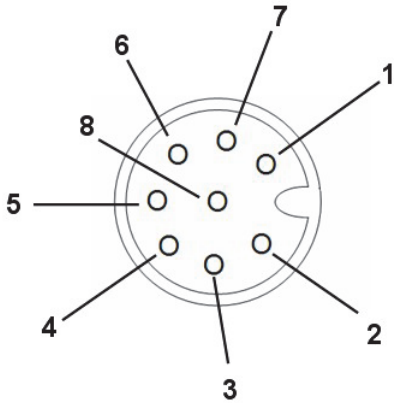

Pin	Function
1	V+
2	V-
3	V-
4	TX (-)
5	RX (+)
6	TX (+)
7	V+
8	RX (-)

A-4-3 Grounding and Isolation

Important: Mounting a camera to grounded conductive material may cause communication problems or unreliable operation. If you need to mount the camera to a bracket or plate, be sure that a proper ground connection is available. If a proper ground is not available, electrical isolation of the camera should be performed. Using Omron Microscan's Isolation Mounting Kit, P/N 98-9000064-01, will ensure that no ground loop or other external electrical noise can occur through the camera.

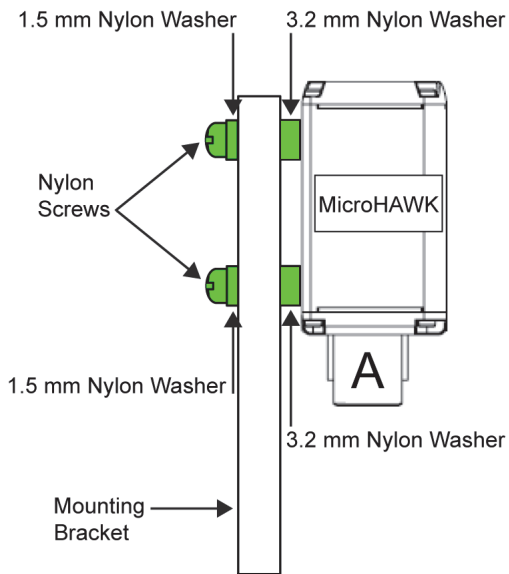

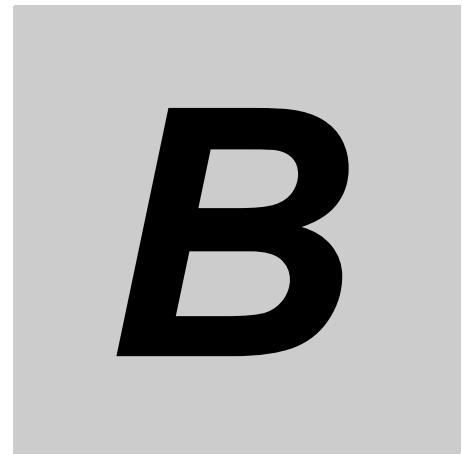

Appendix B - Cable Specifications

This section contains images, pin assignments, and wire colors for MicroHAWK F320-F, F330-F, F420-F, and F430-F Smart Camera cables.

Note: Cable specifications are published for information only. Omron Microscan does not guarantee the performance or quality of cables provided by other suppliers

B-1	MicroHAWK Cables	B-2
------------	-------------------------------	------------

B-1 MicroHAWK Cables

B-1-1 MicroHAWK F320-F Cables with Pinouts and Wire Colors

V320-WRX-2M – RJ50 to RS-232 and External Power Straight – 2 M

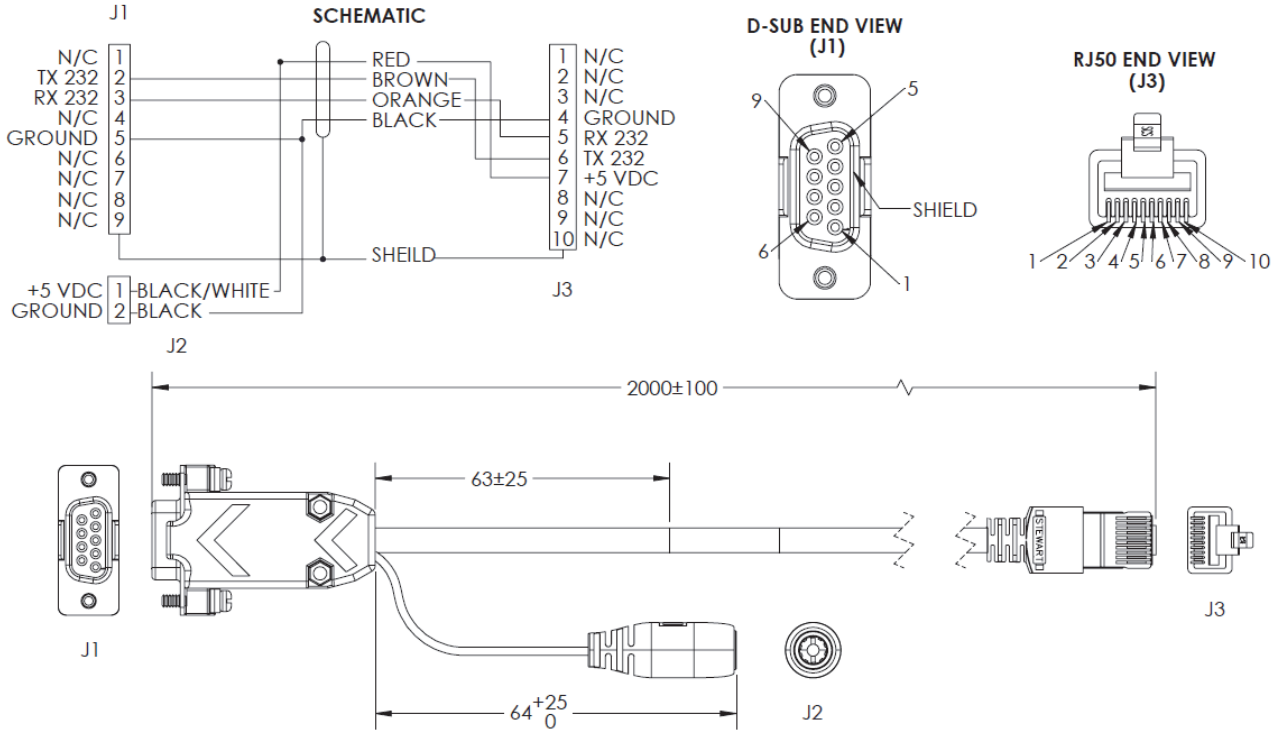

V320-WRXLR-2M – RJ50 to RS-232 and External Power Right Angle – 2 M

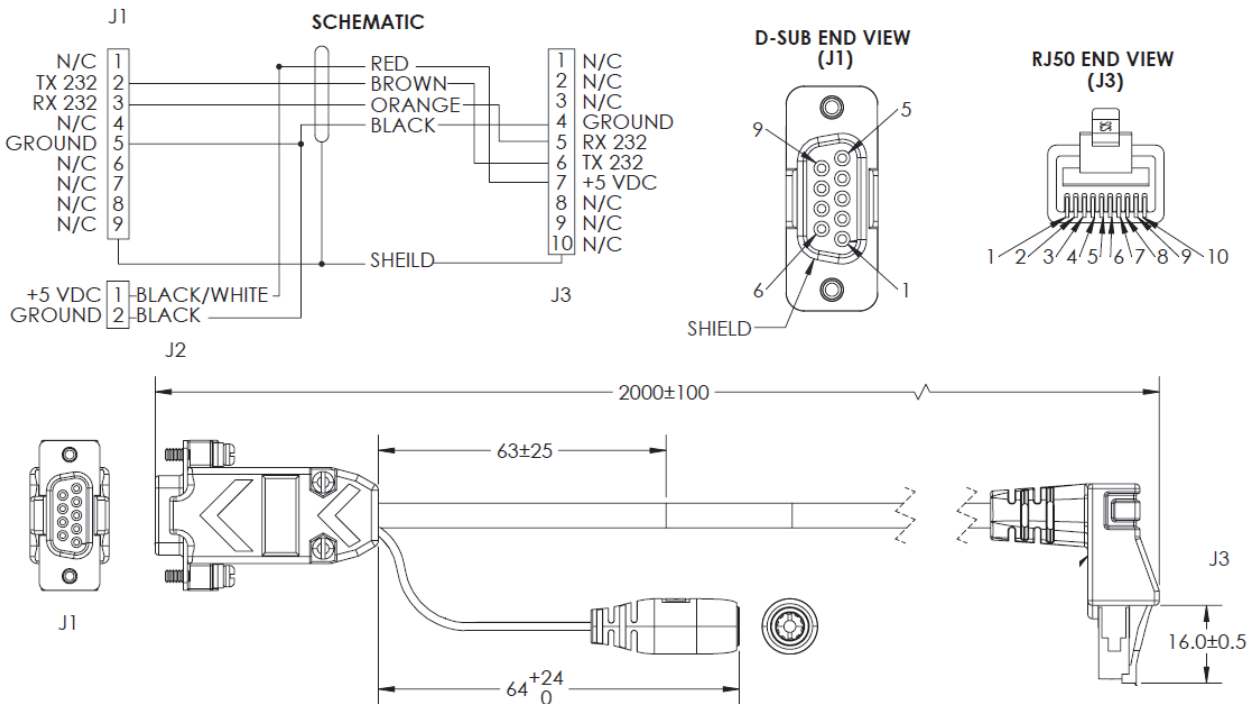

V320-W8-3M – RJ50 to Flying Leads, Straight – 3 M

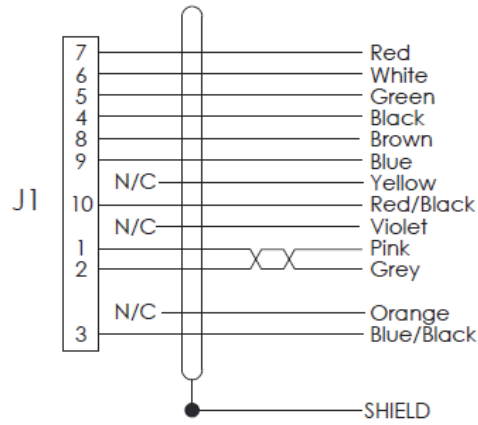

RJ50 END VIEW (J1)

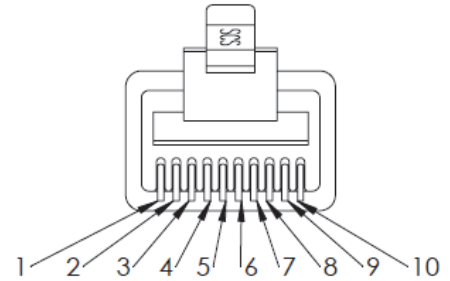

SCHEMATIC

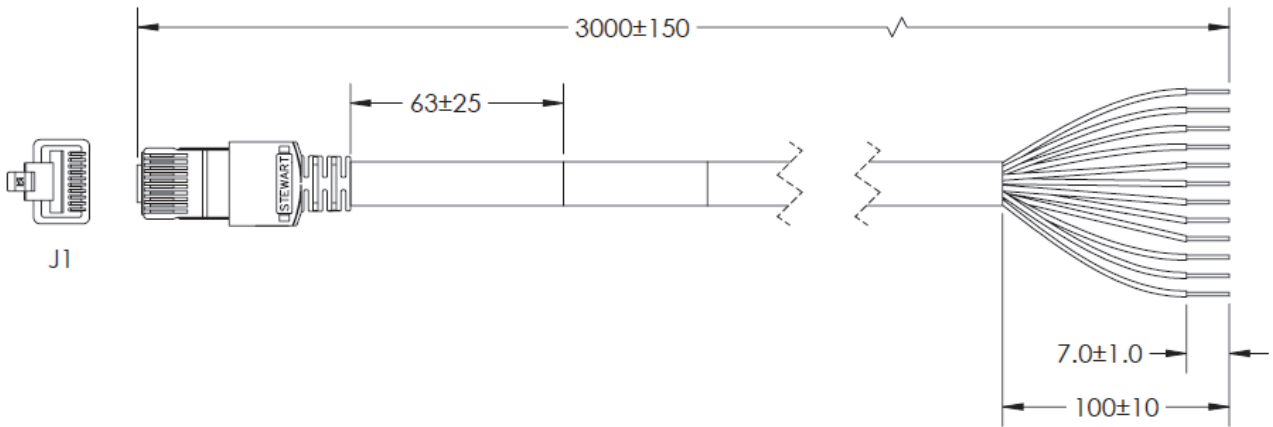

B

V320-W8LR-3M – RJ50 to Flying Leads, Right Angle to the Right – 3 M

SCHEMATIC

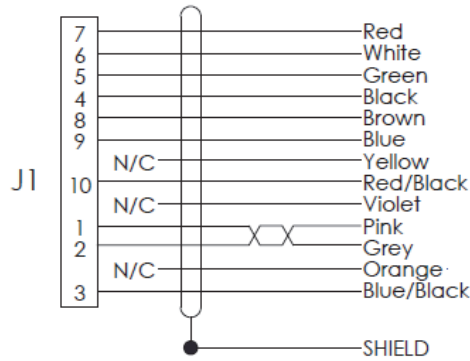

RJ50 END VIEW (J1)

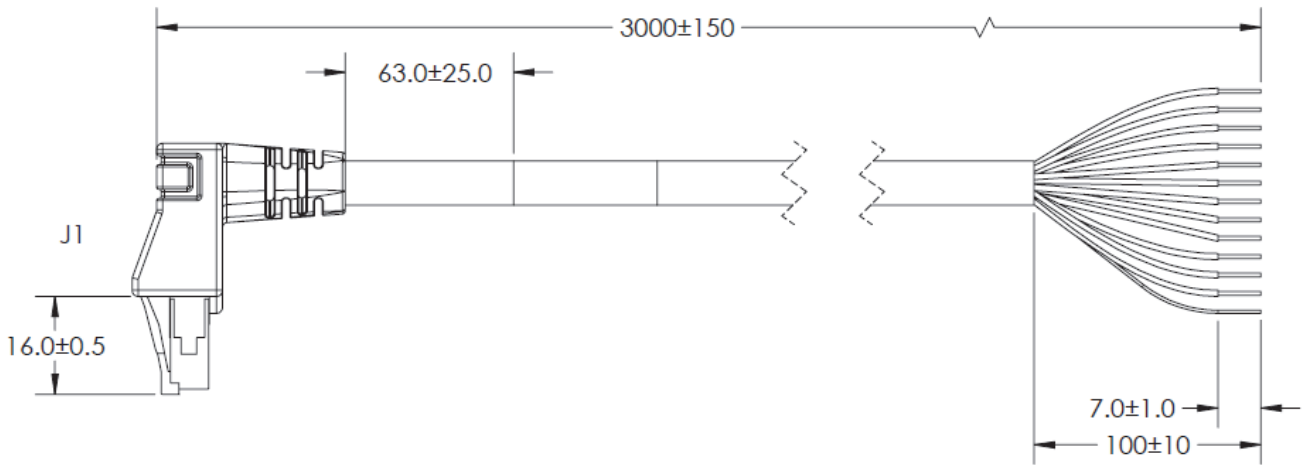
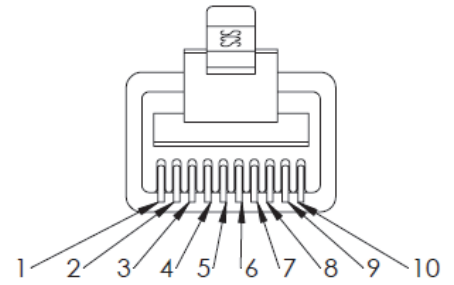

V320-WR-1M – Adapter V/F320-F to all F420-F Cable Accessories, RJ50 to DB-15 – 1 M

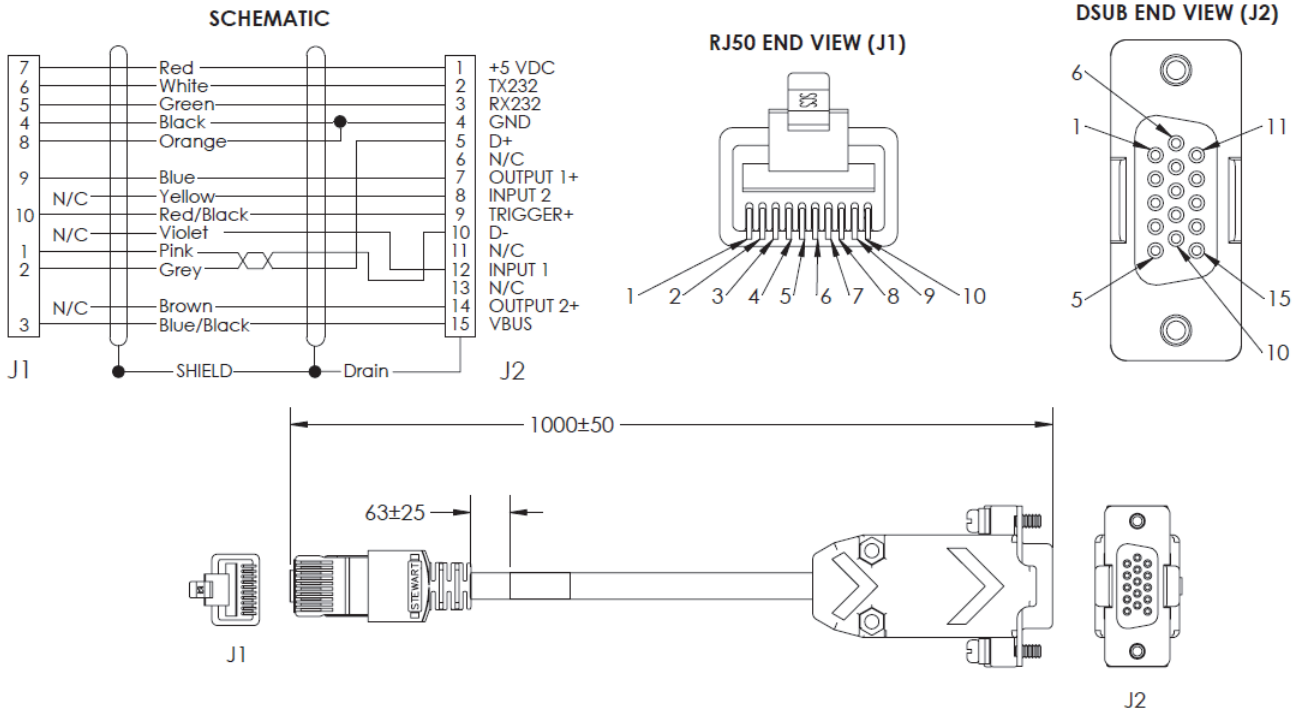

B

V320-WRLR-1M – Adapter V/F320-F to all F420-F Cable Accessories, Right Angle to the Right, RJ50 to DB-15 – 1 M

D-SUB END VIEW (J2)

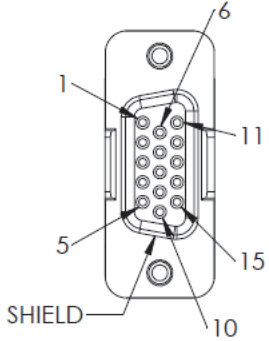

RJ50 END VIEW (J1)

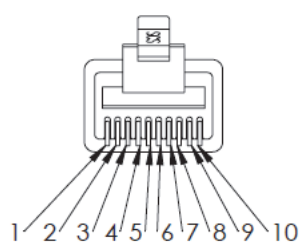

SCHEMATIC

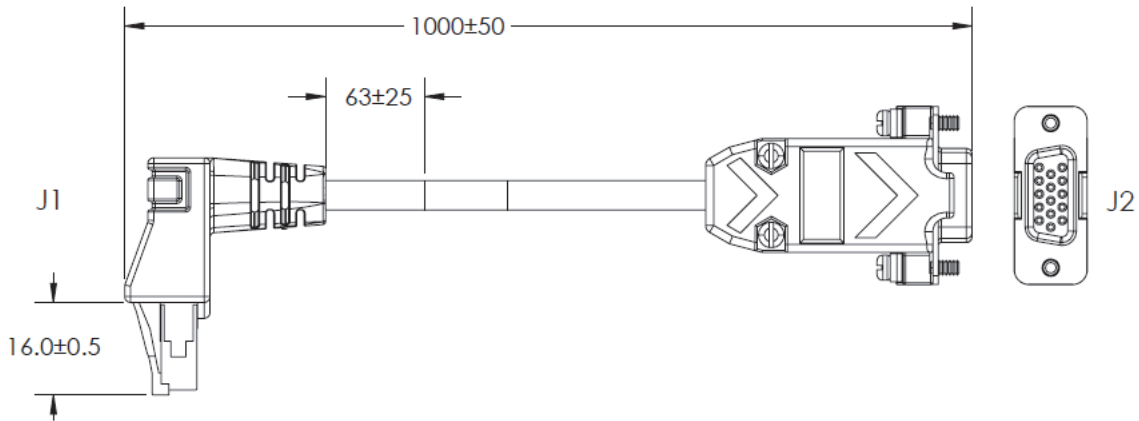
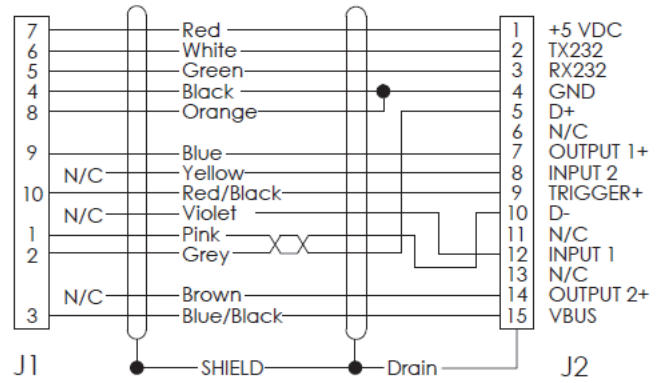

B-1-2 MicroHAWK F330-F Cables

Standard Ethernet Cables, In-Cabinet Use; Standard RJ45 Connectors on Both Ends; Green

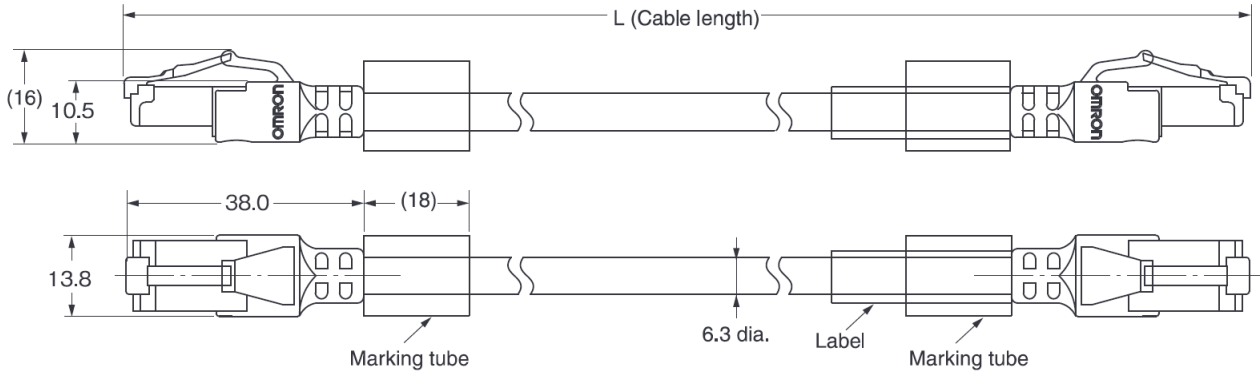

B

Standard Ethernet Cables, Out-of-Cabinet Use; Rugged RJ45 Connectors on Both Ends; Light Blue

or

High Flex Ethernet Cables for Robot and Cable Tray Use; Rugged RJ45 Connectors on Both Ends; Light Blue

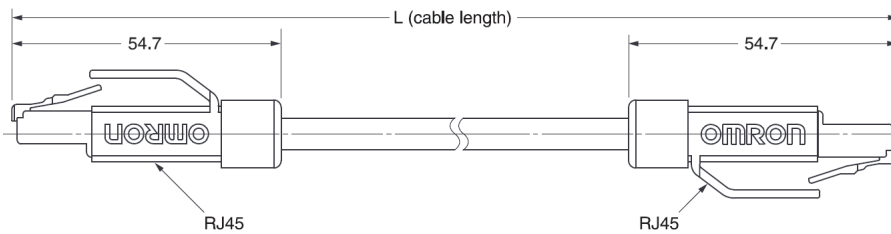

B-1-3 MicroHAWK F420-F Cables with Pinouts and Wire Colors

V420-WUB-1M – USB Breakout Cable – 1 M

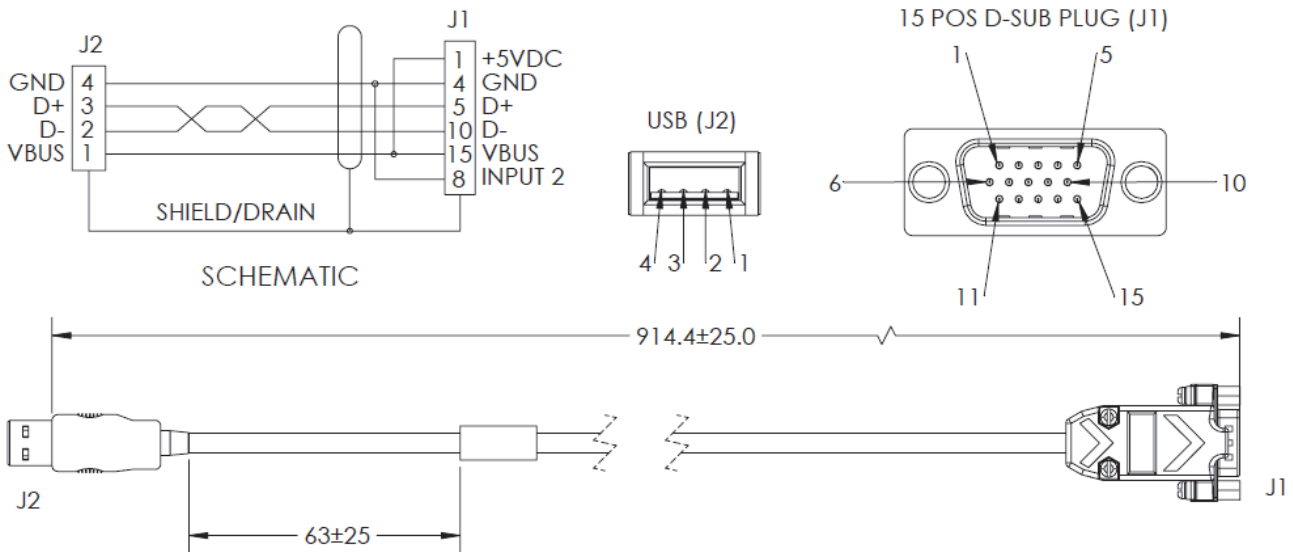

V420-WUX-1M – Cable – USB Breakout with External Power Input – 1 M

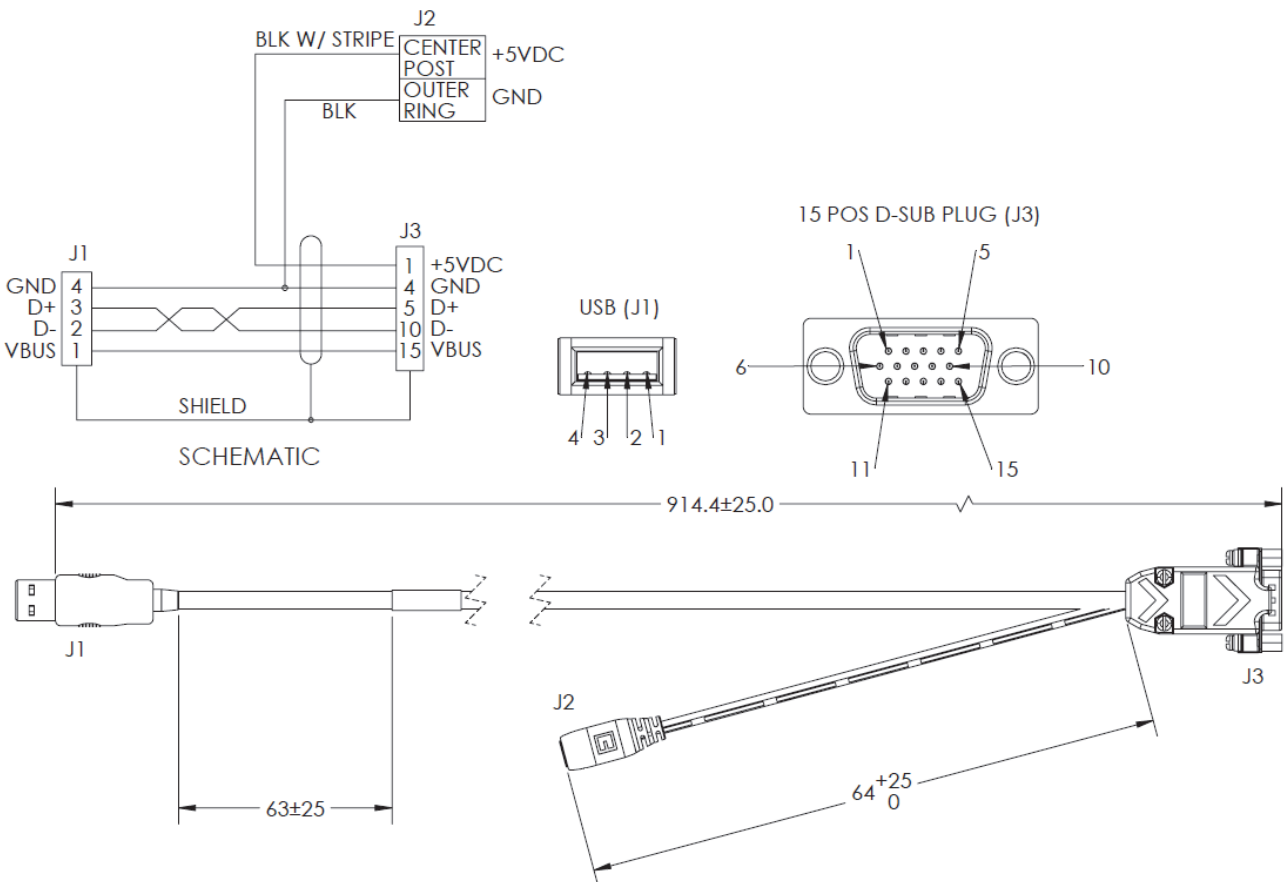

V420-WRX-1M – Cable – RS-232 Breakout (DB-15) and External Power Input – 1 M

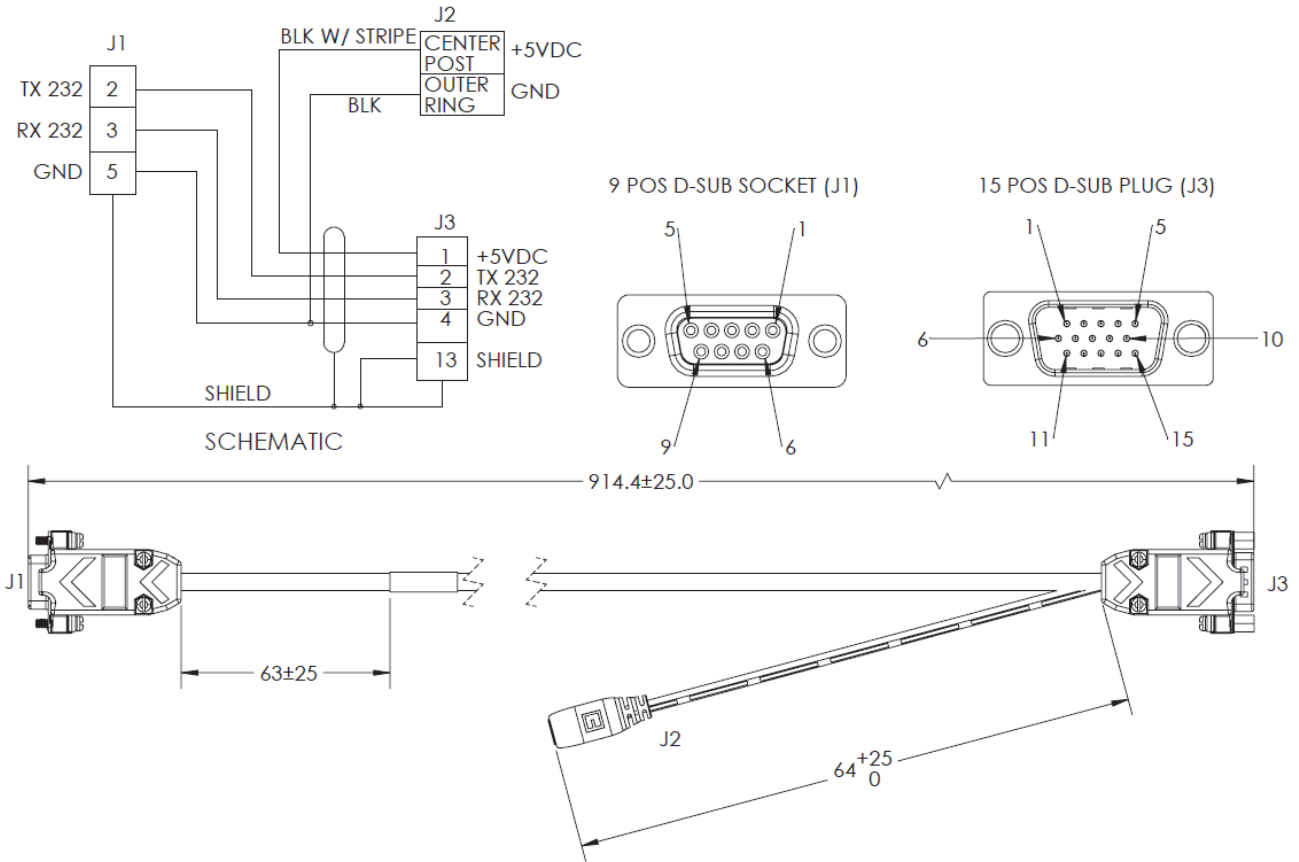

B

V420-WU8X-1M – Cable – USB, IO, and Power Breakout – 1 M

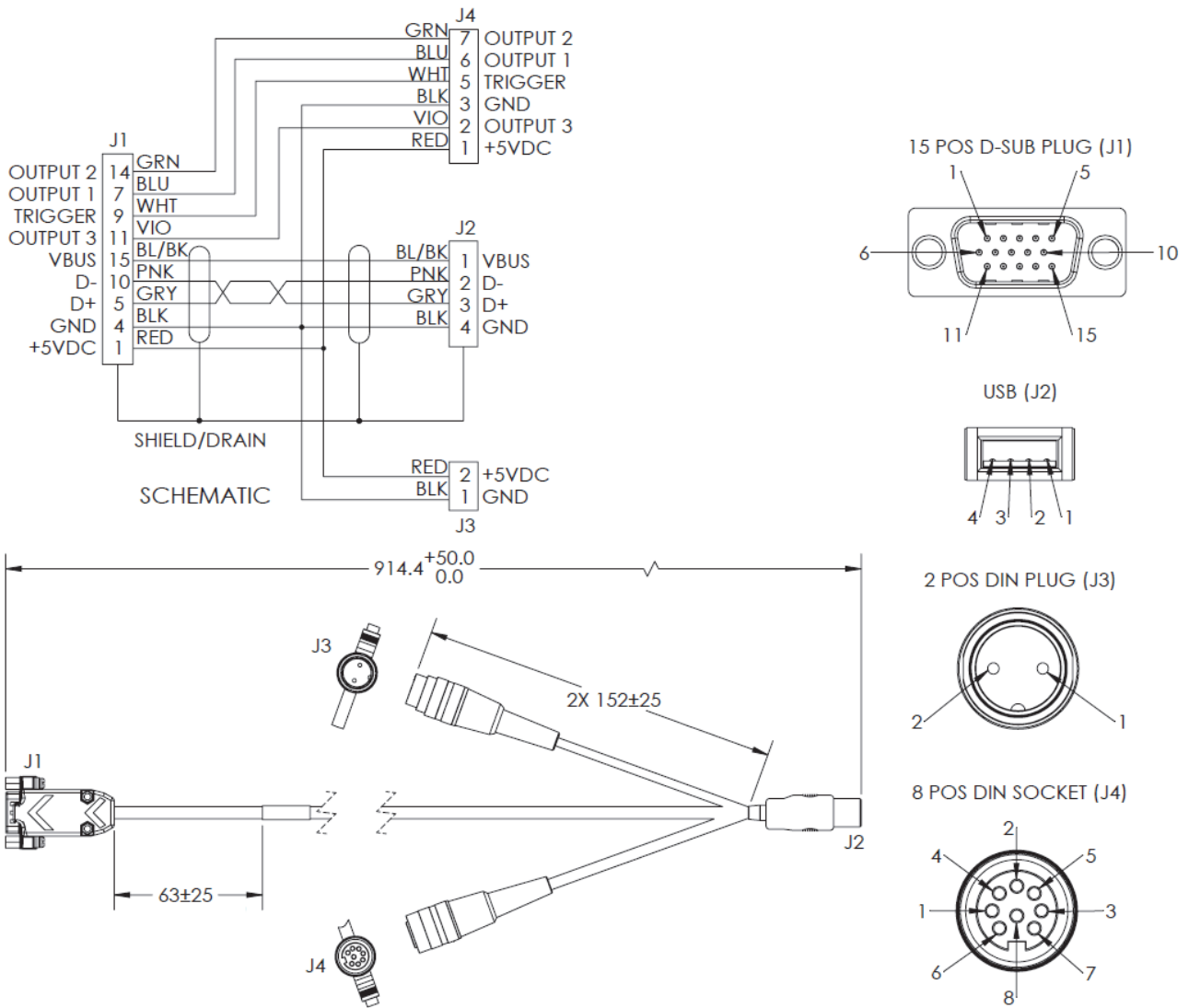

V420-WRU8X-1M – Cable – RS-232, USB, IO, and Power Breakout – 1 M

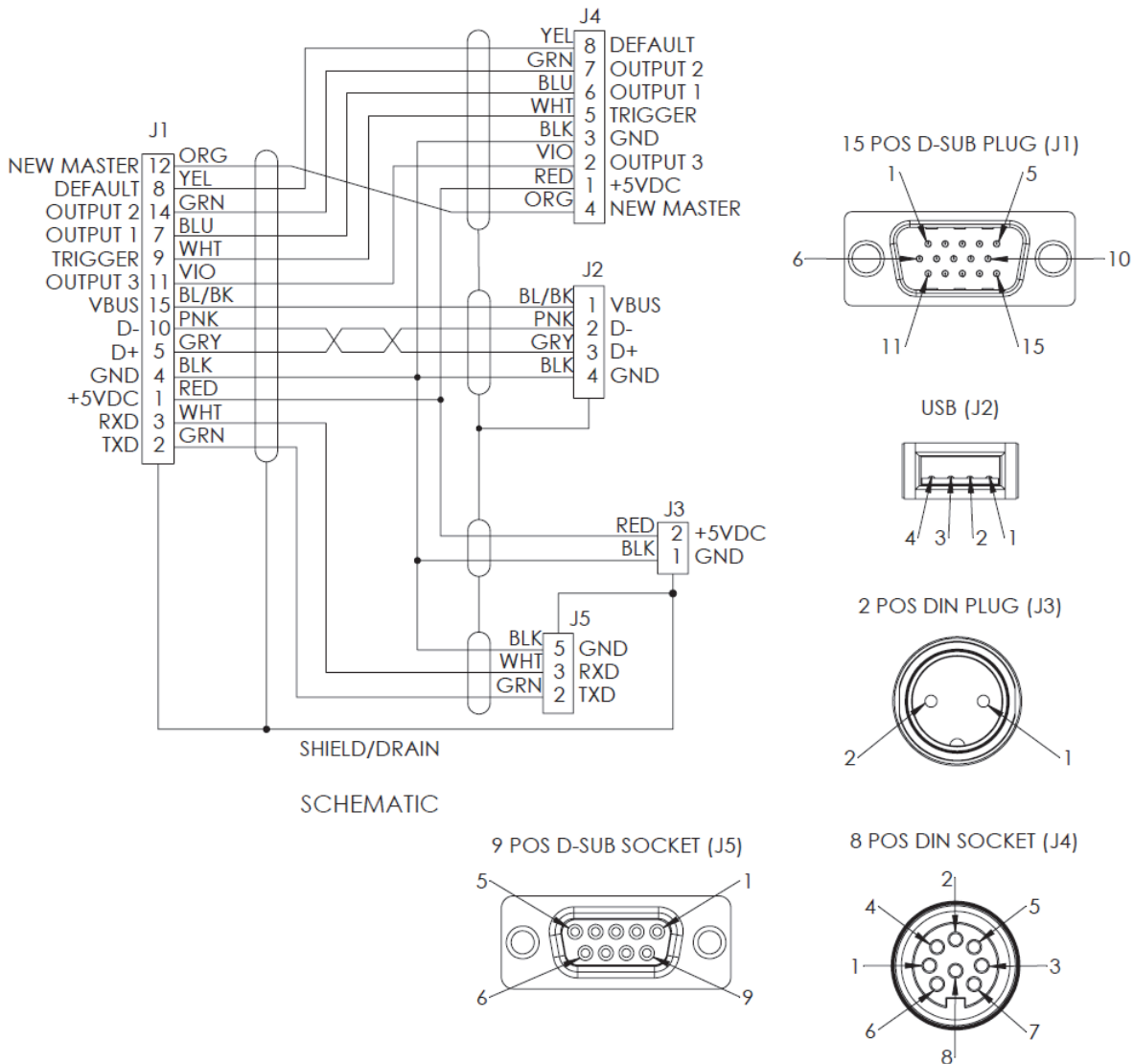

B

61-000151-01 – Cable – Trigger, IO and Power Breakout – 900 MM

Plugs into the IO connector on the V420-WU8X-1M and V420-WRU8X-1M cables.

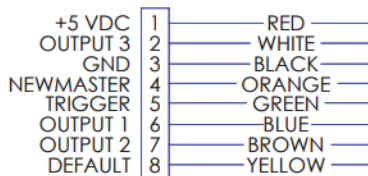

CABLE SPECIFICATIONS

8 CONDUCTOR STRANDED 22AWG
UL LISTED
PVC JACKET - BLACK OR GREY

J1

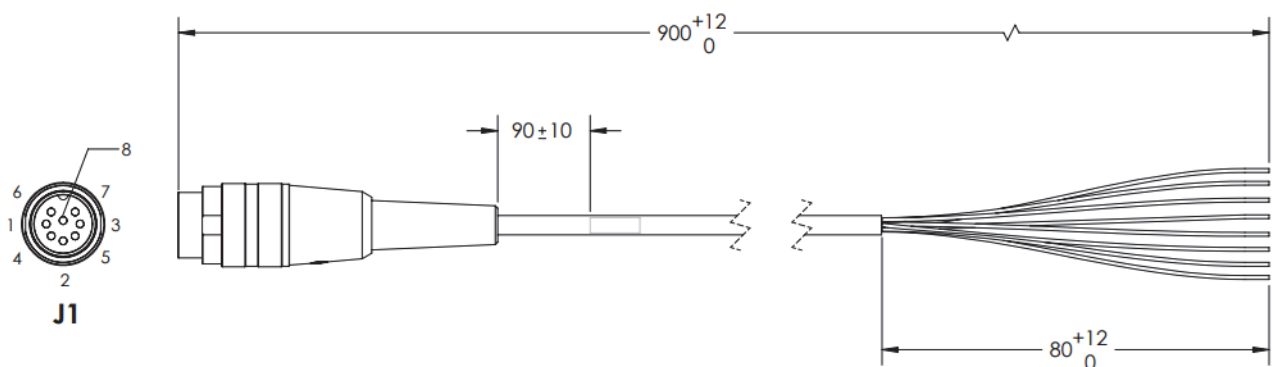

B-1-4 MicroHAWK F430-F Cables with Pinouts and Wire Colors

V430-WE-1M – Ethernet Communication Cable, Straight Connector, M12 Plug on Camera to RJ45 Connector – 1 M

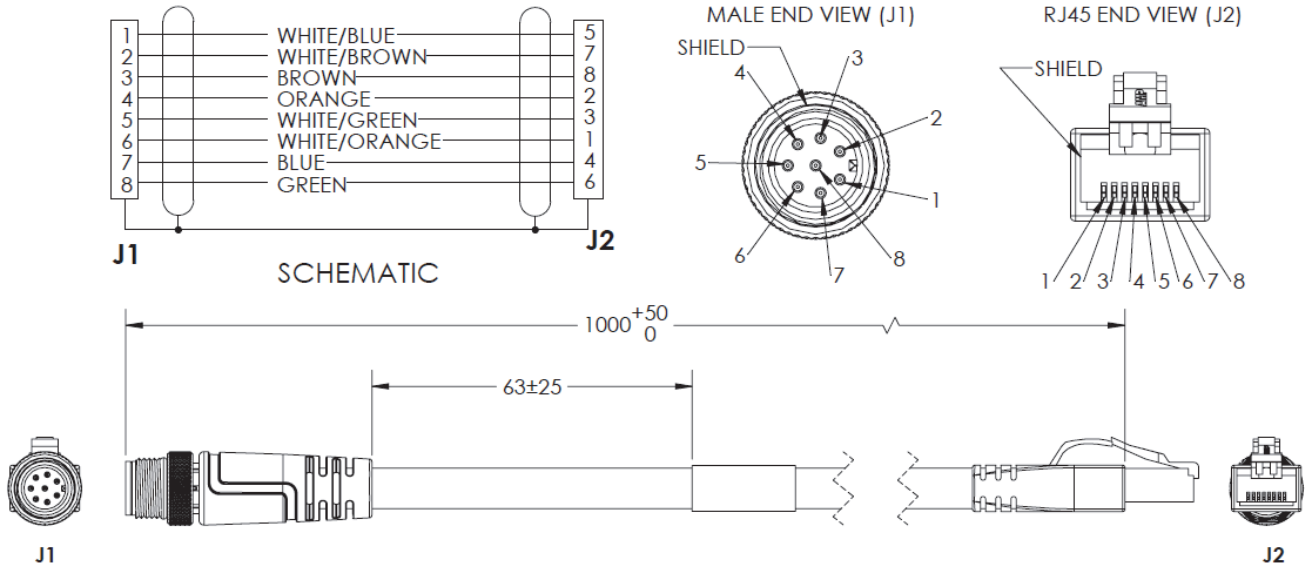

V430-WE-3M – Ethernet Communication Cable, Straight Connector, M12 Plug on Camera to RJ45 Connector – 3 M

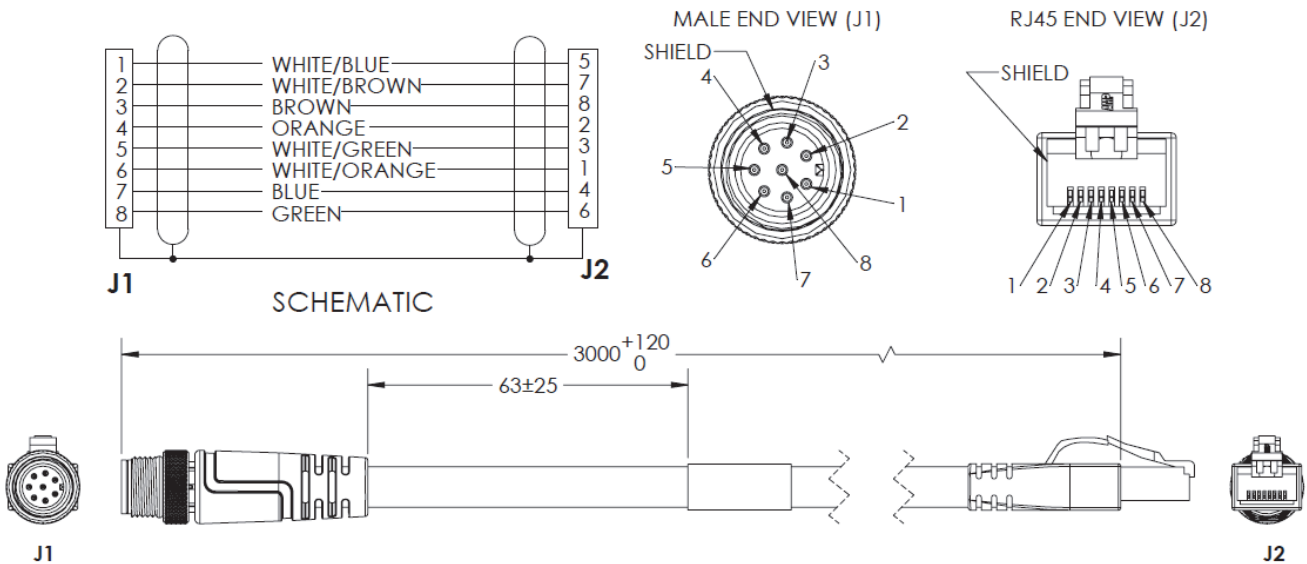

V430-WE-5M – Ethernet Communication Cable, Straight Connector, M12 Plug on Camera to RJ45 Connector – 5 M

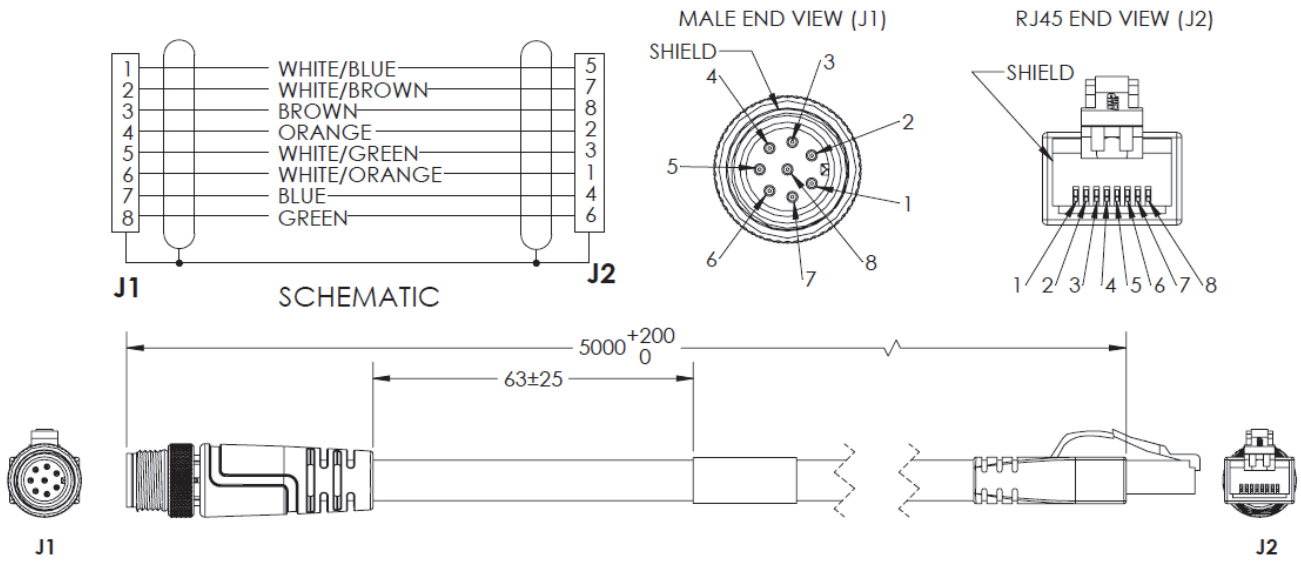

B

V430-WELU-3M – Ethernet Communication Cable, Right Angle Up* Connector, M12 Plug on Camera to RJ45 – 3 M

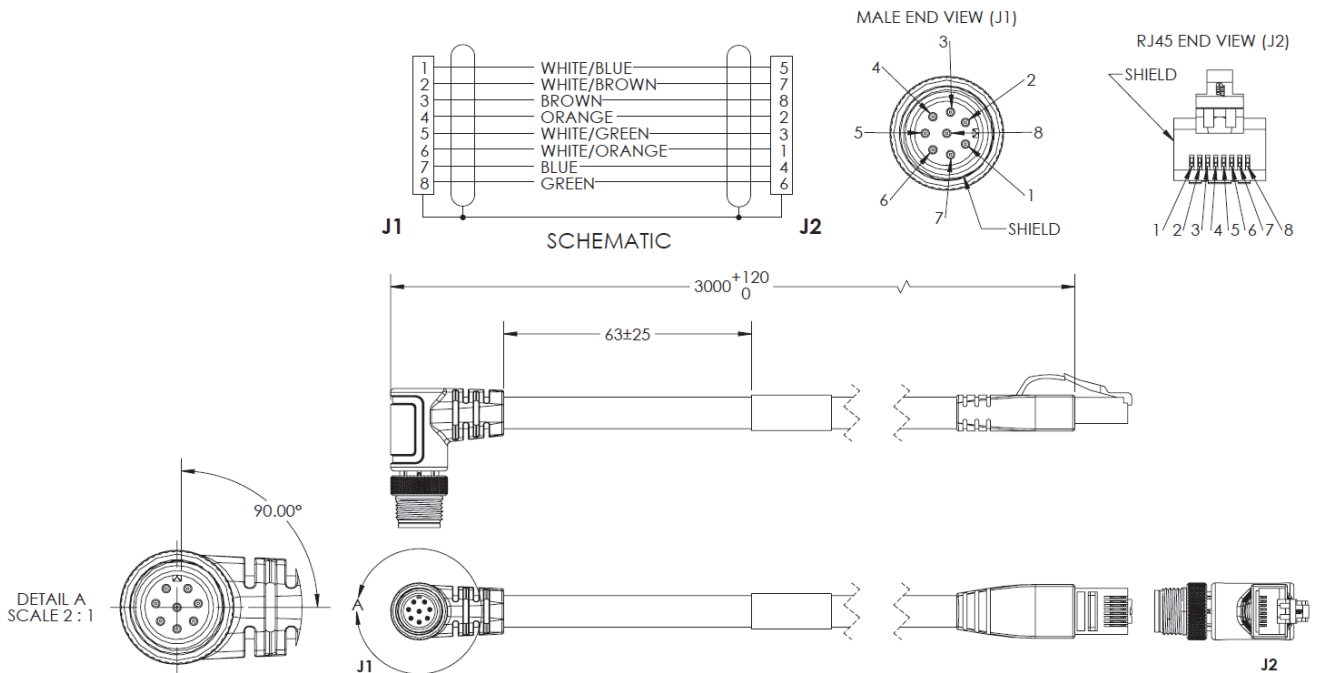

*Right angle up



V430-WELD-3M – Ethernet Communication Cable, Right Angle Down* Connector, M12 Plug on Camera to RJ45 – 3 M

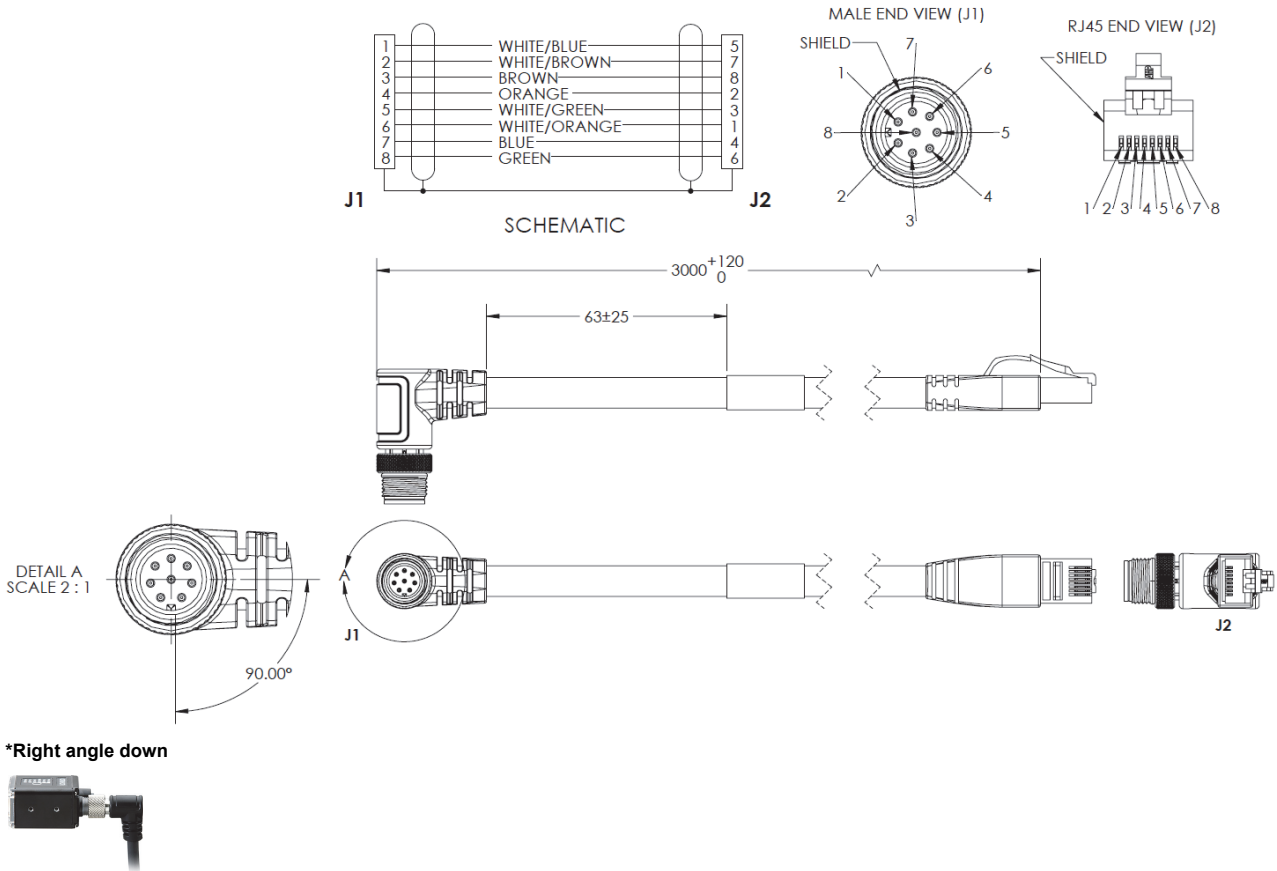

V430-WQ-1M – Camera to QX-1 Interconnect Cable, M12 Socket to M12 Plug – 1 M

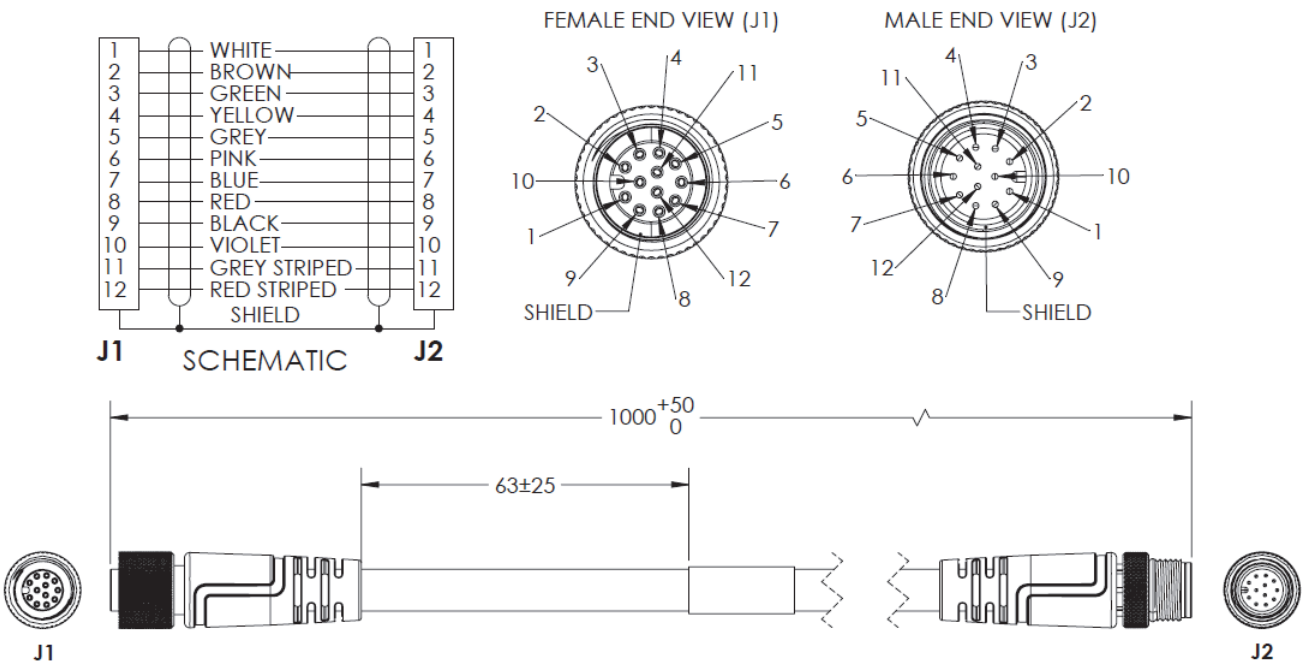

V430-WQF-1M – Camera to QX-1 Interconnect Cable, M12 Socket to M12 Plug, with Power Filter – 300 MM

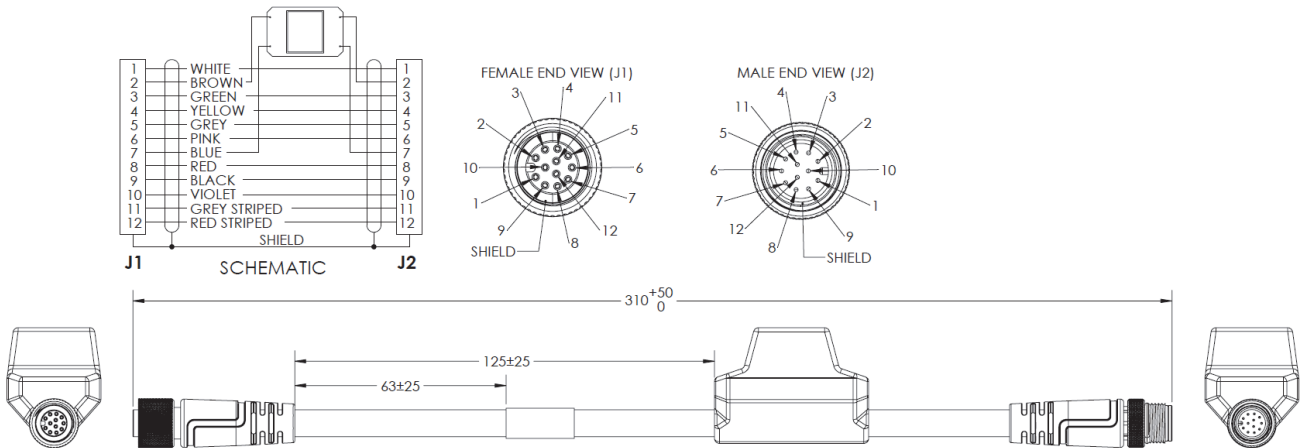

B

V430-WQ-3M – Camera to QX-1 Interconnect Cable, M12 Socket to M12 Plug – 3 M

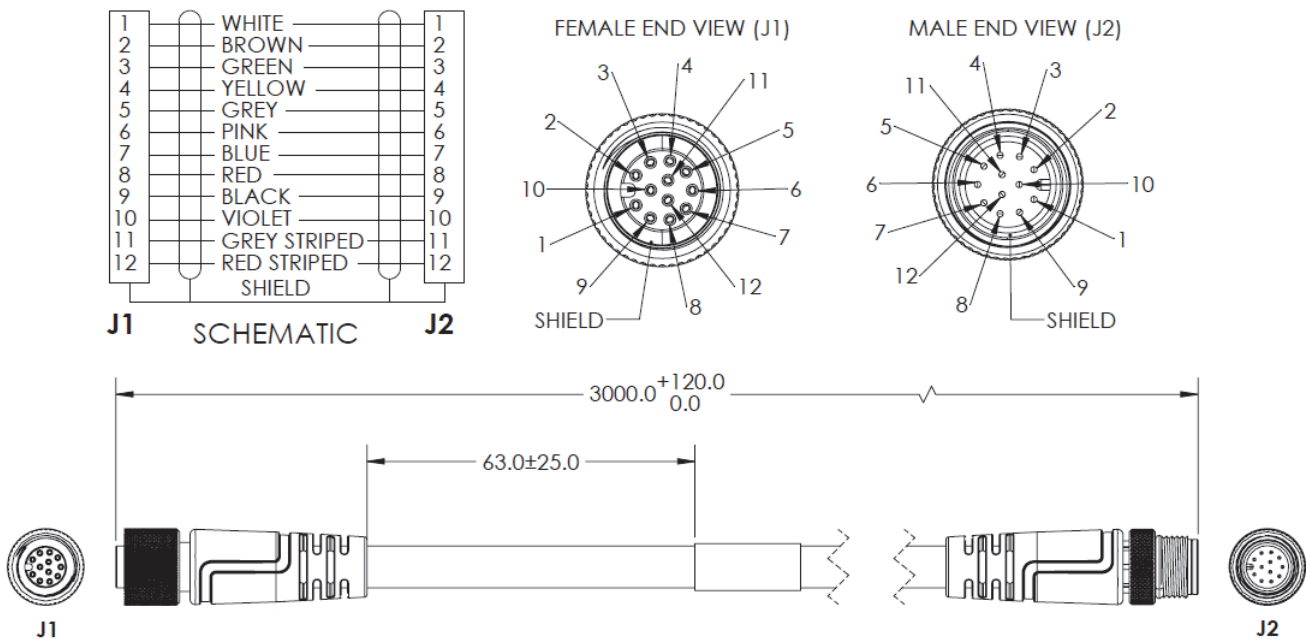

V430-WQ-5M – Camera to QX-1 Interconnect Cable, M12 Socket to M12 Plug – 5 M

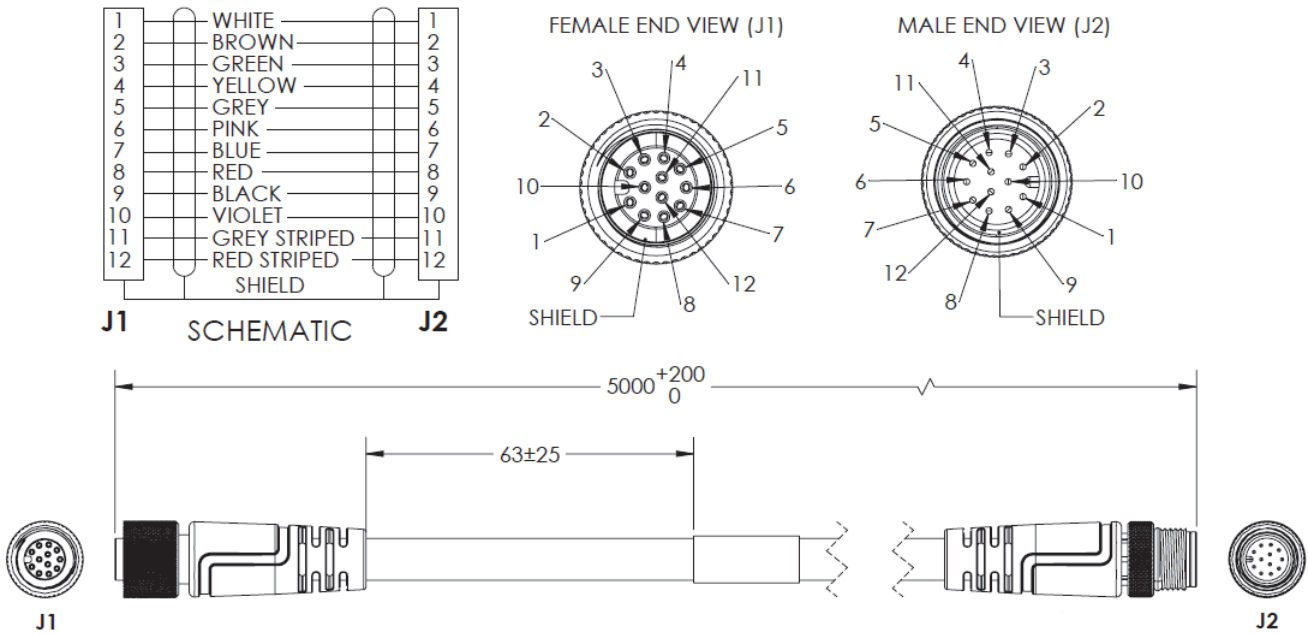

61-000204-01 – QX-1 to Smart Light, M12 Plug on QX-1 to 5-Pin Socket on Light, Continuous Power – 3 M

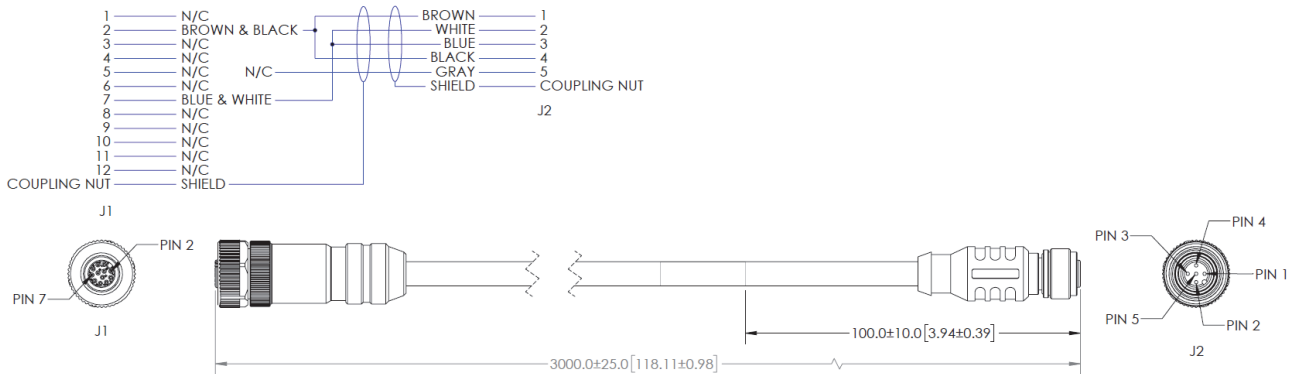

61-000218-01 – QX-1 to Smart Light, M12 Plug on QX-1 to 5-Pin Socket on Light, Strobe Control – 3 M

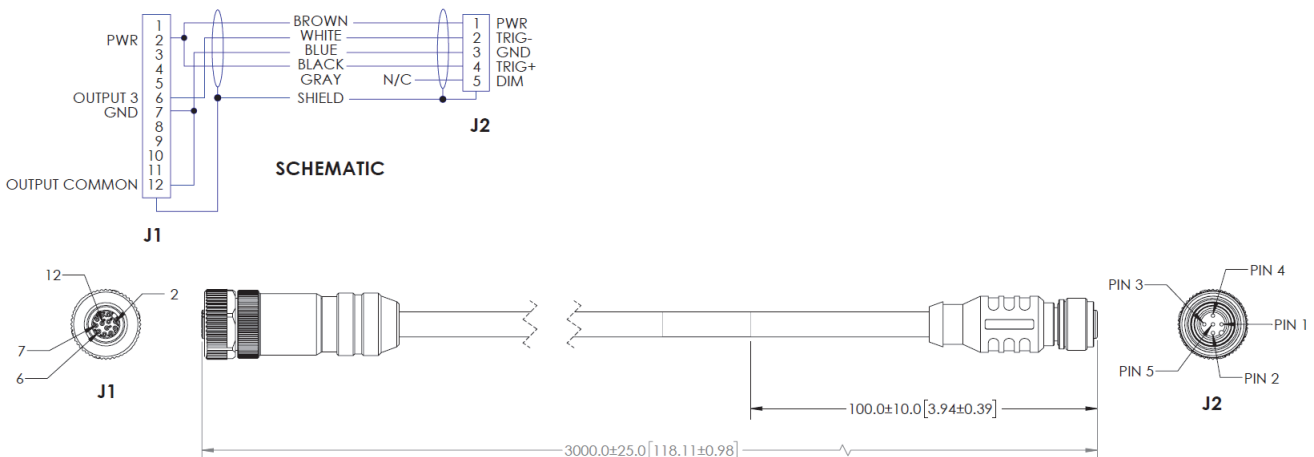

61-9000135-01 – Y Cable, Camera / Power and Smart Light Power (Continuous On) – 1 M

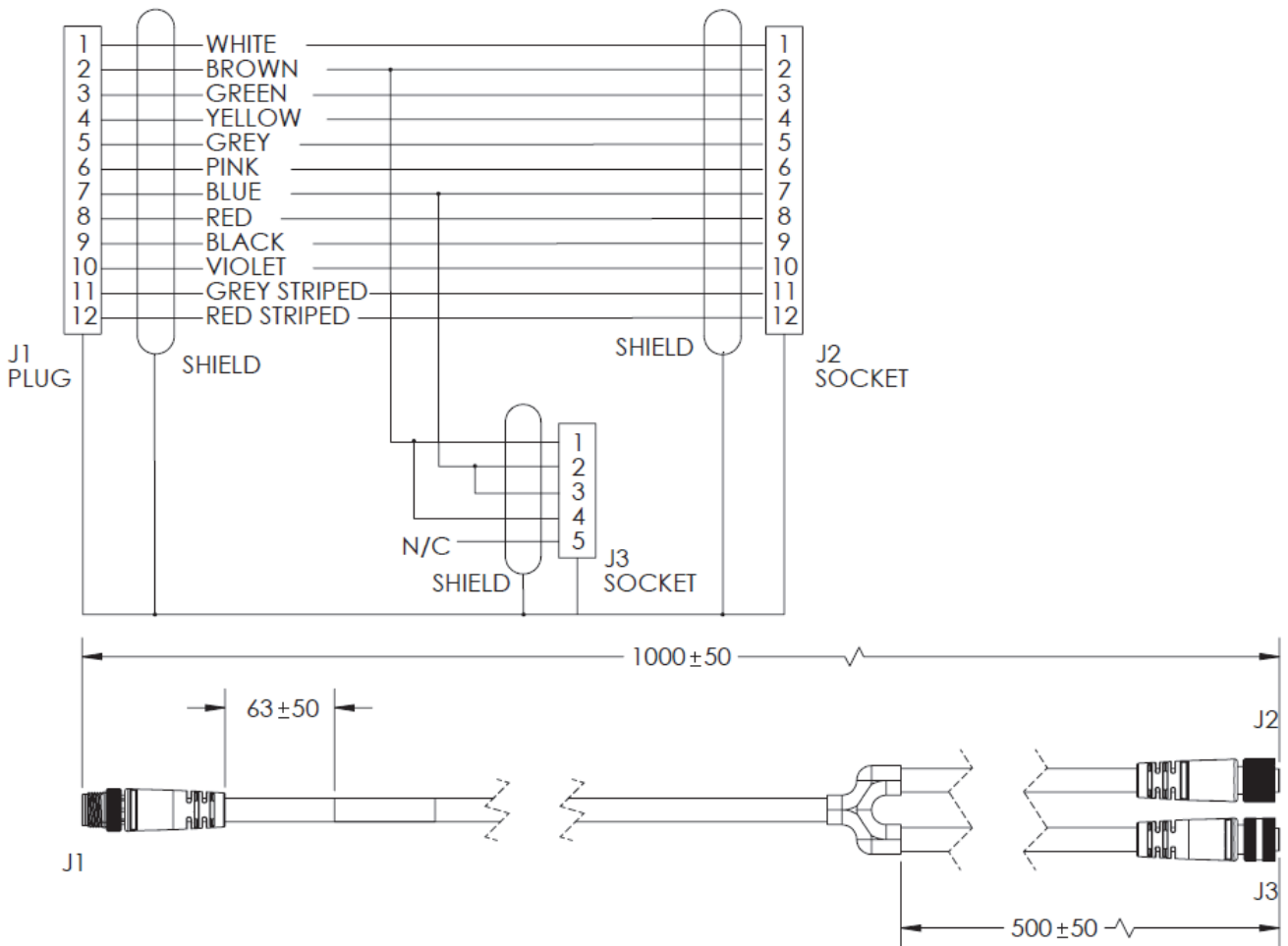

B

61-9000137-01 – Y Cable, Camera / Power and Smart Light Strobe Control – 1 M

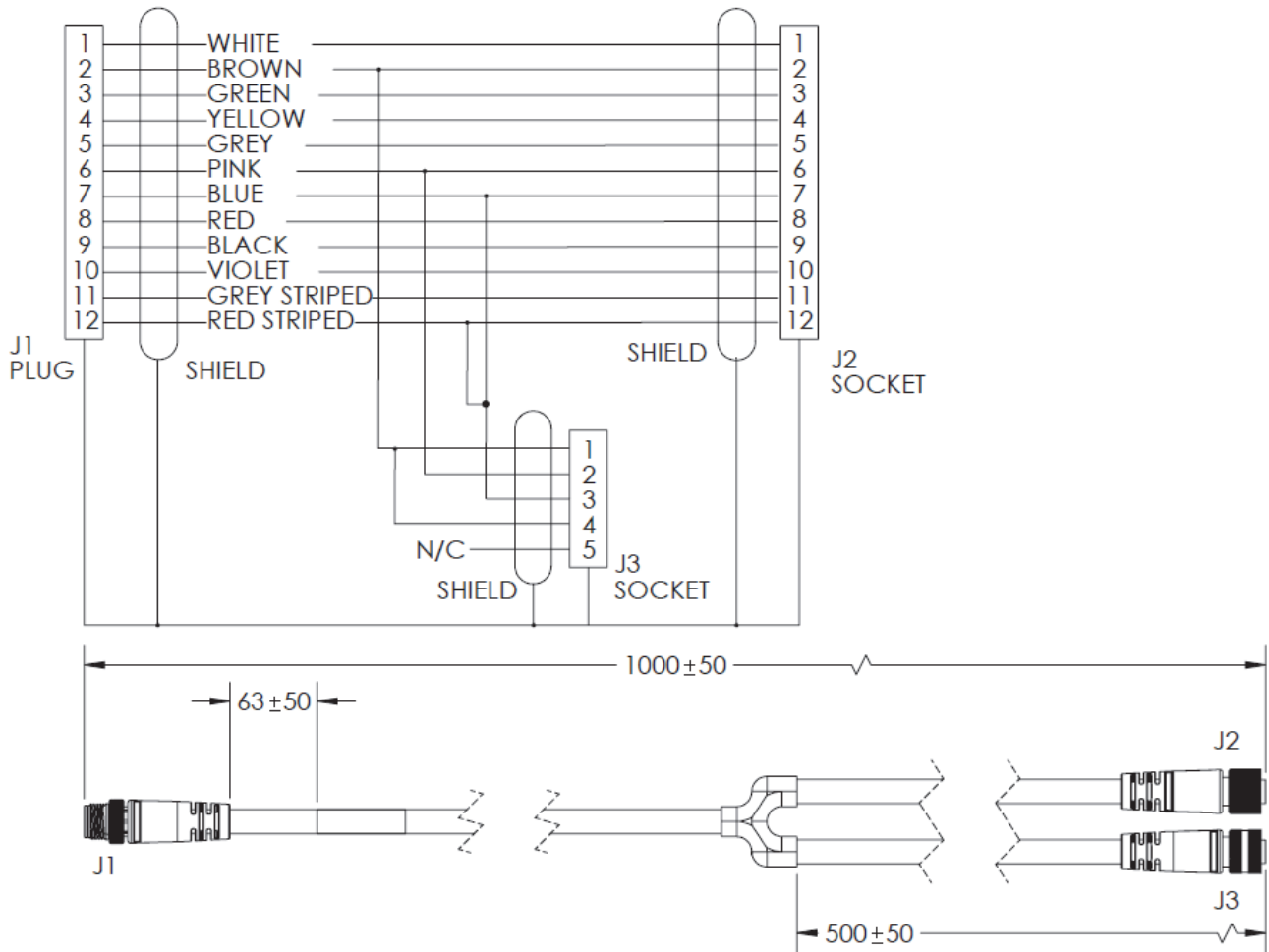

V430-W8-3M – M12 to Flying Leads Cable, Straight Power, IO, RS-232, USB – 3 M

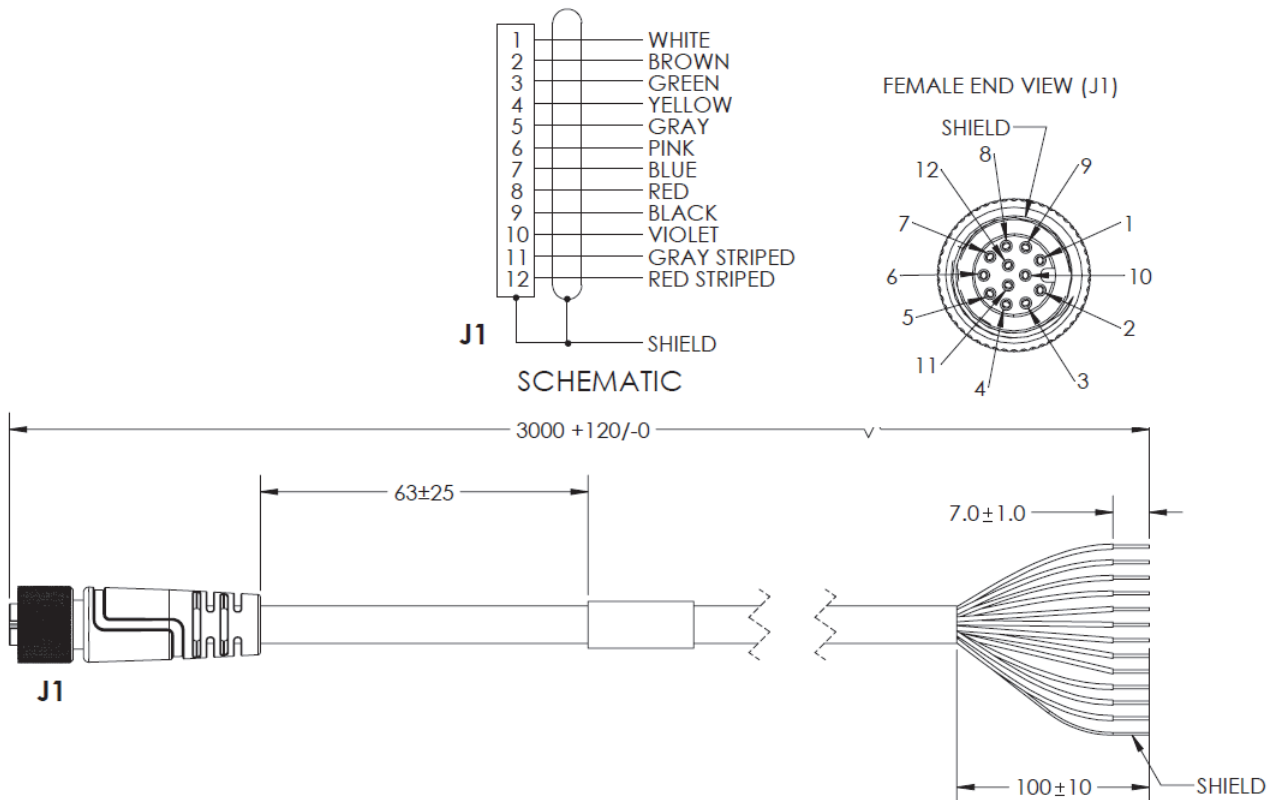

V430-W8F-3M – M12 to Flying Leads Cable, with Power Filter – 3 M

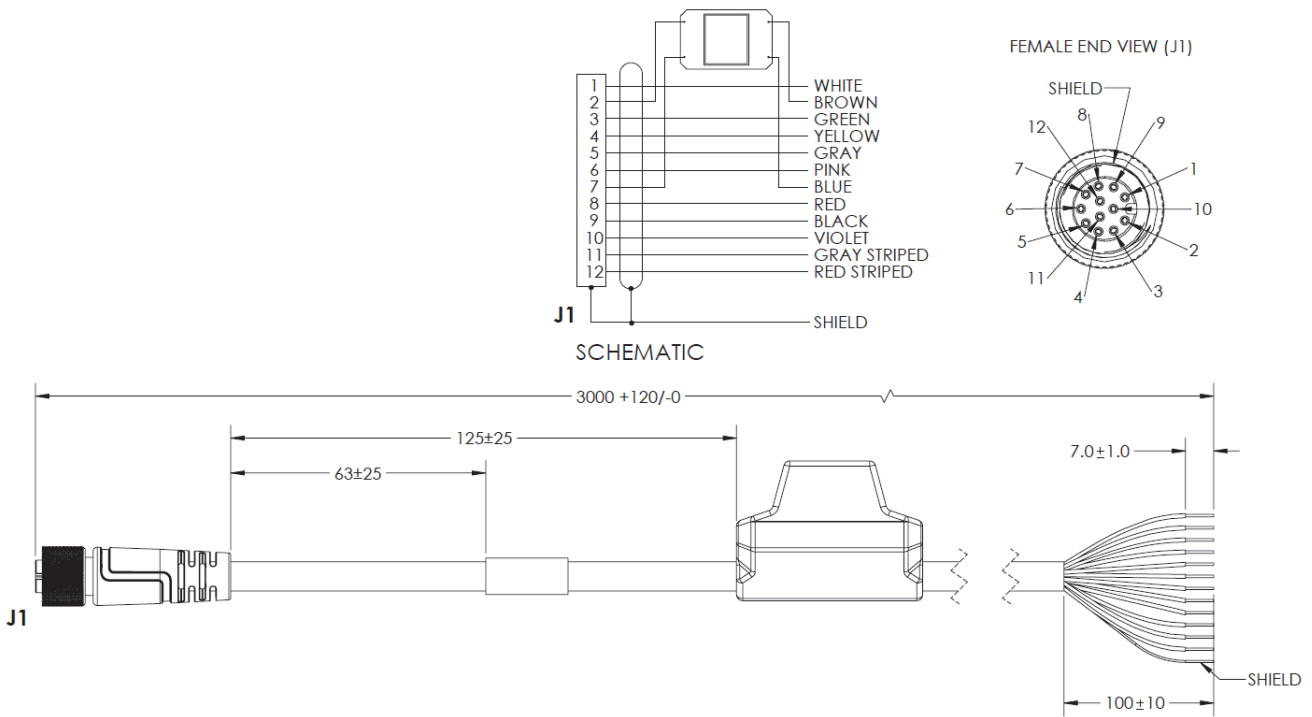

B

V430-W8-5M – M12 to Flying Leads Cable, Straight Power, IO, RS-232, USB – 5 M

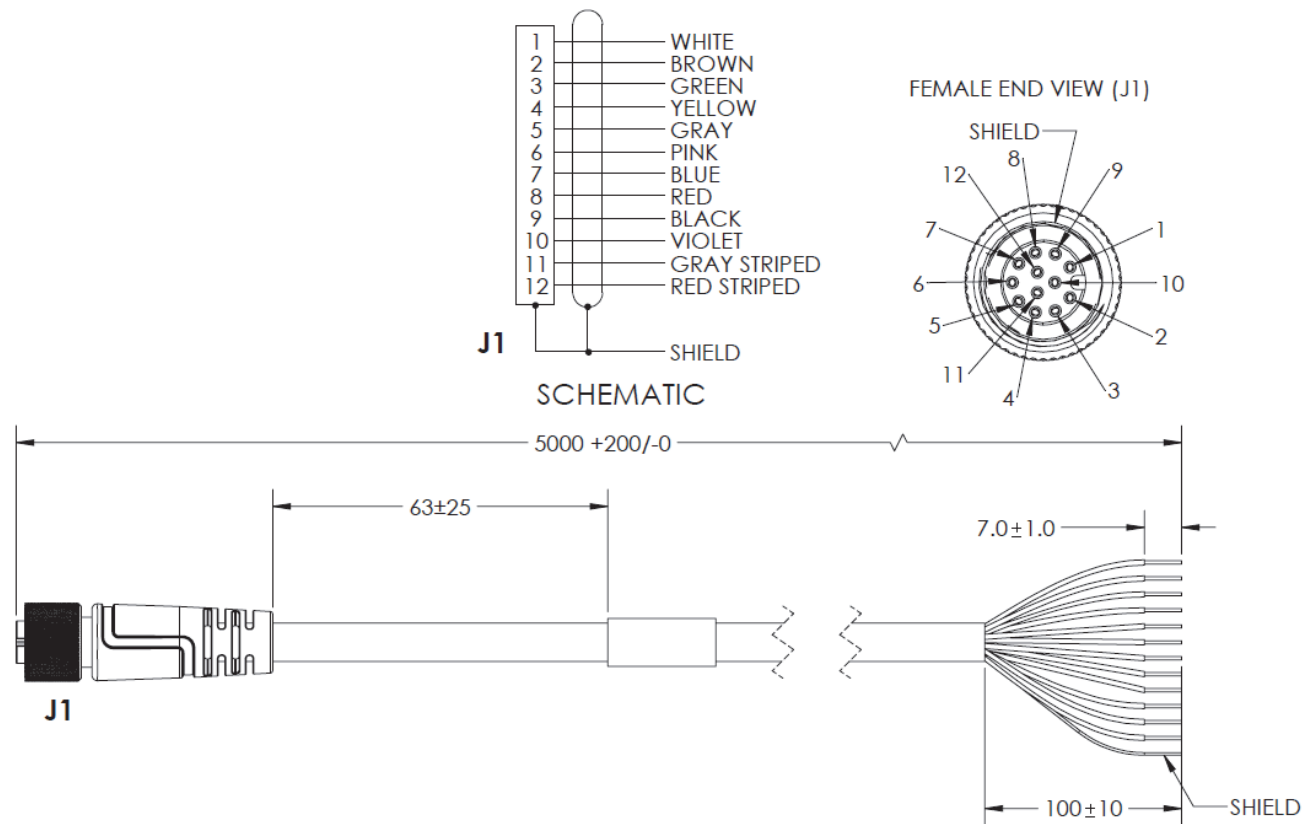

V430-W8F-5M – M12 to Flying Leads Cable, with Power Filter – 5 M

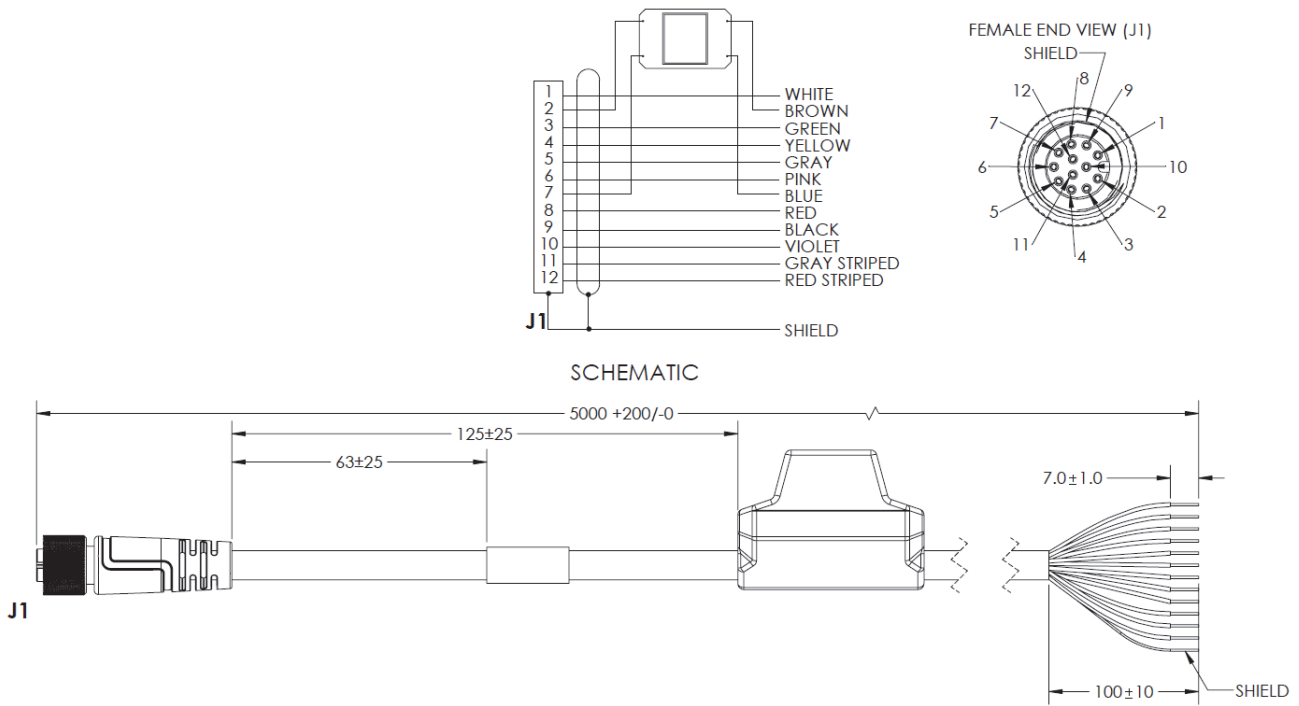

V430-W8LU-3M – M12 to Flying Leads Cable, Right Angle Up* Power, IO, RS-232, USB – 3 M

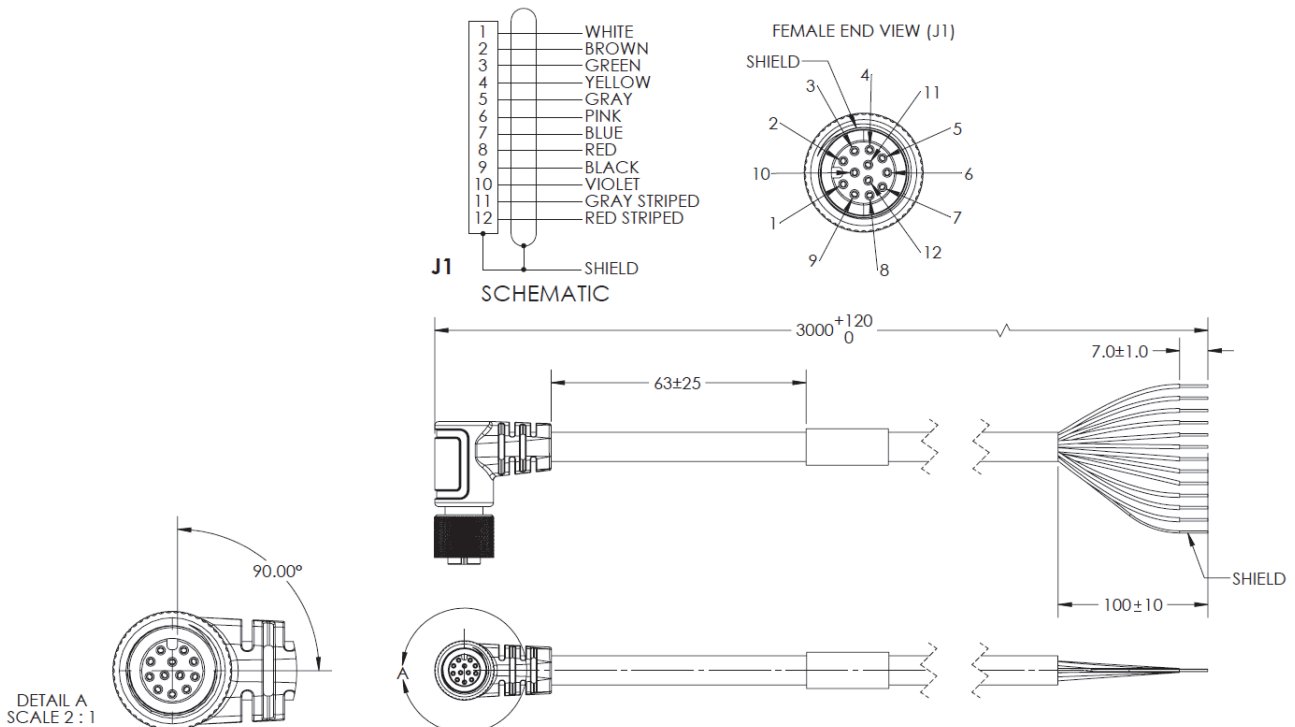

*Right angle up



V430-W8LUF-3M – M12 to Flying Leads Cable, Right Angle Up*, with Power Filter – 3 M

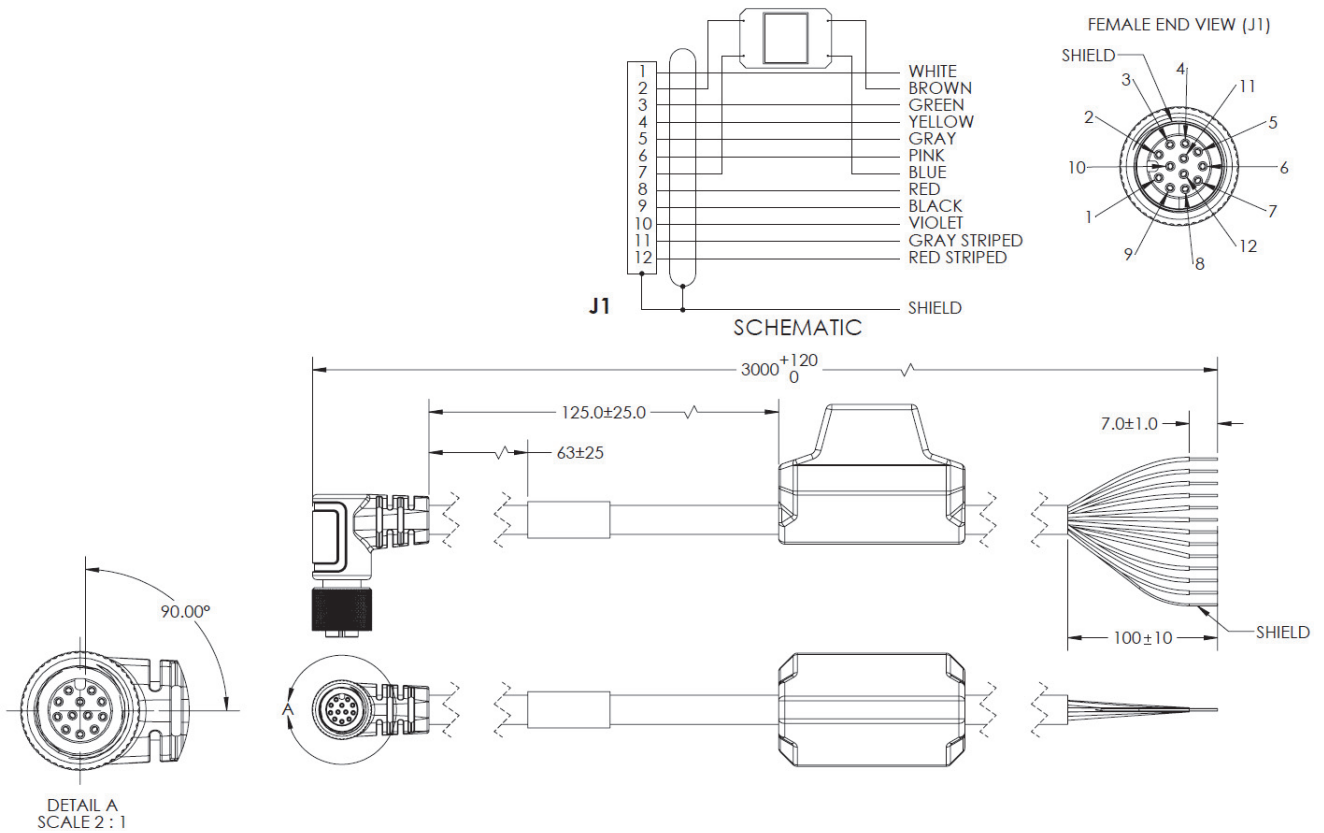

*Right angle up



V430-W8LD-3M – M12 to Flying Leads Cable, Right Angle Down*, Power, IO, RS-232, USB – 3 M

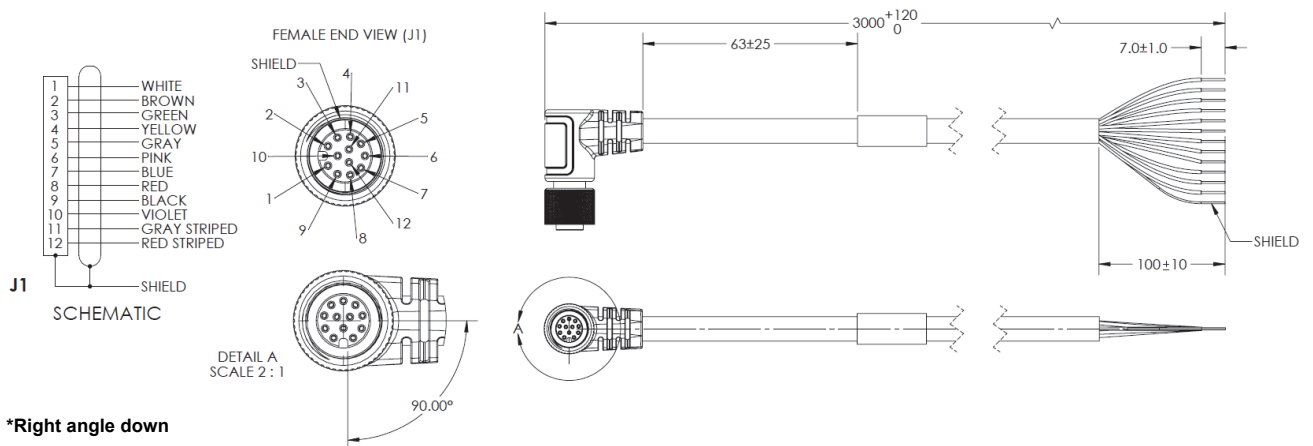

*Right angle down



V430-W8LDF-3M – M12 to Flying Leads Cable, Right Angle Down*, with Power Filter – 3 M

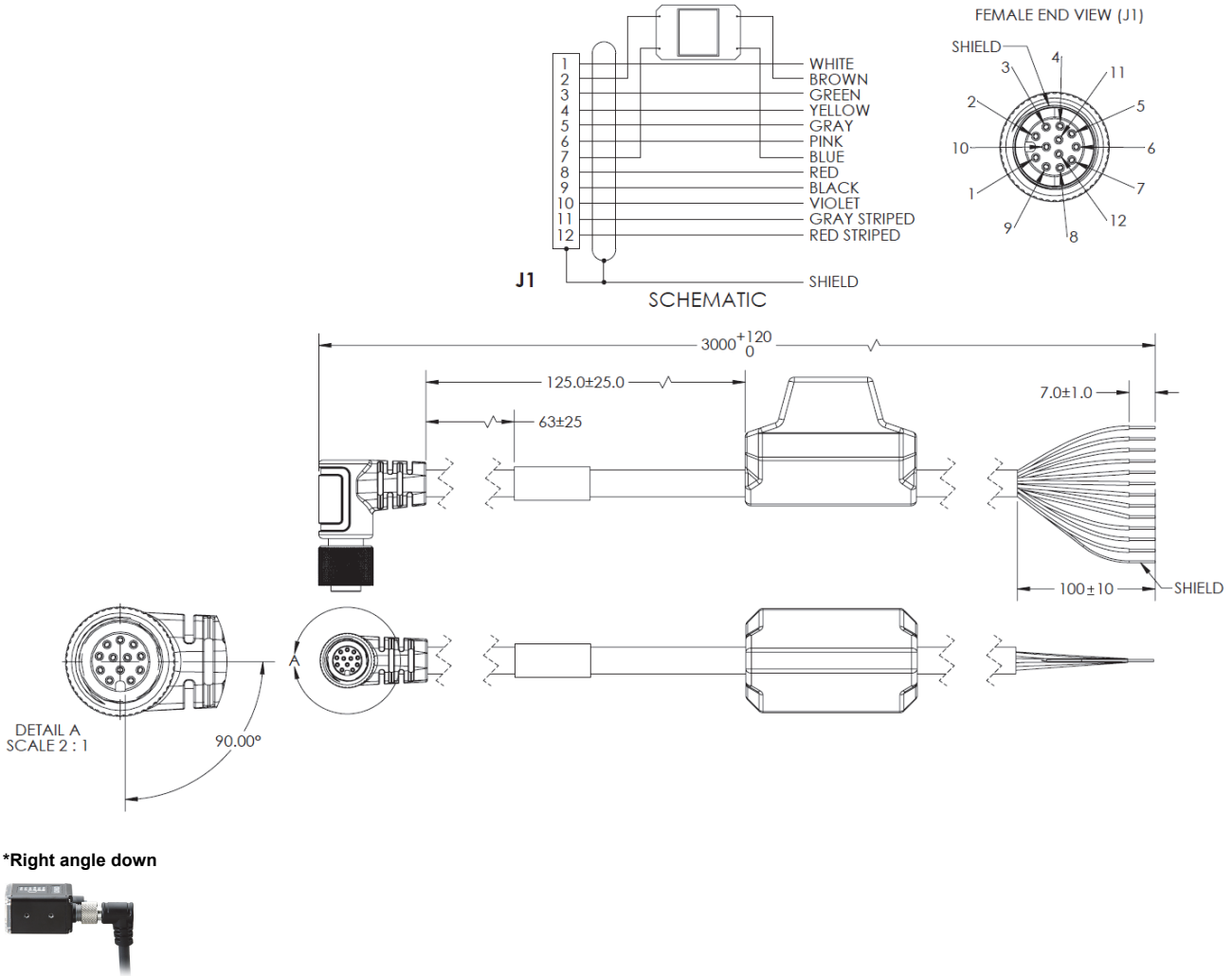

V430-WR-1M – M12 to RS-232 Breakout – 1 M

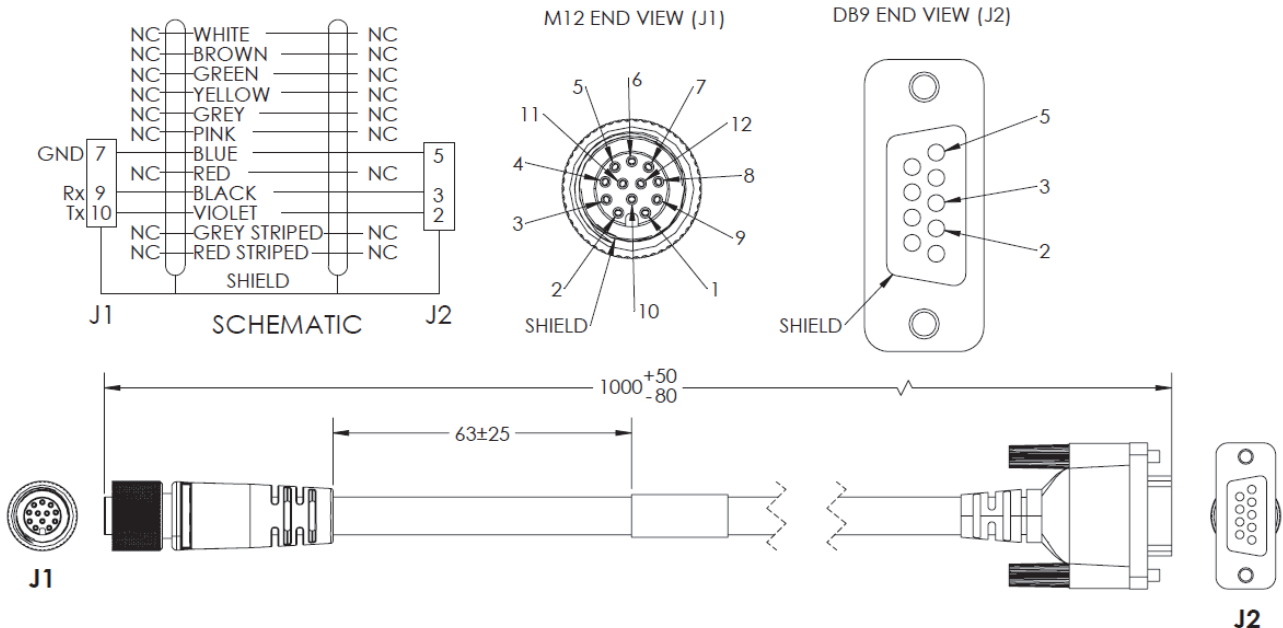

V430-WR-3M – M12 to RS-232 Breakout – 3 M

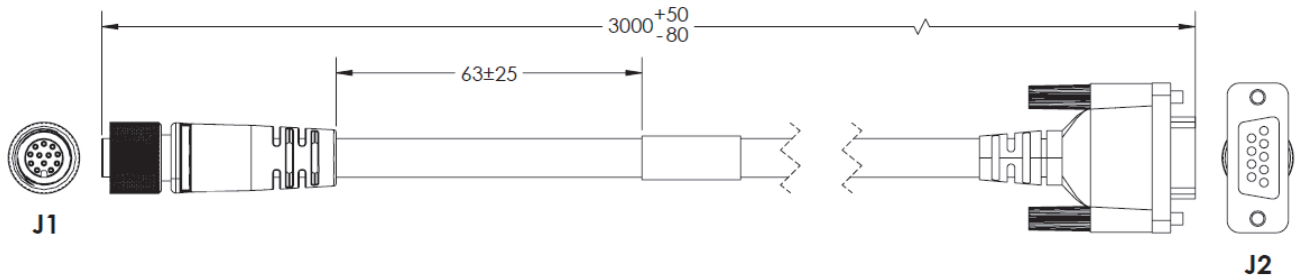
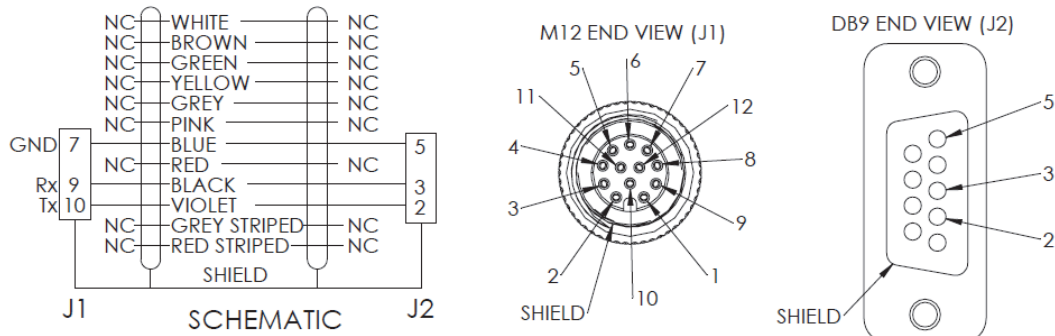

B

V430-WQR-3M – Camera to QX-1 Interconnect Cables with RS-232 Breakout – 2.7 M

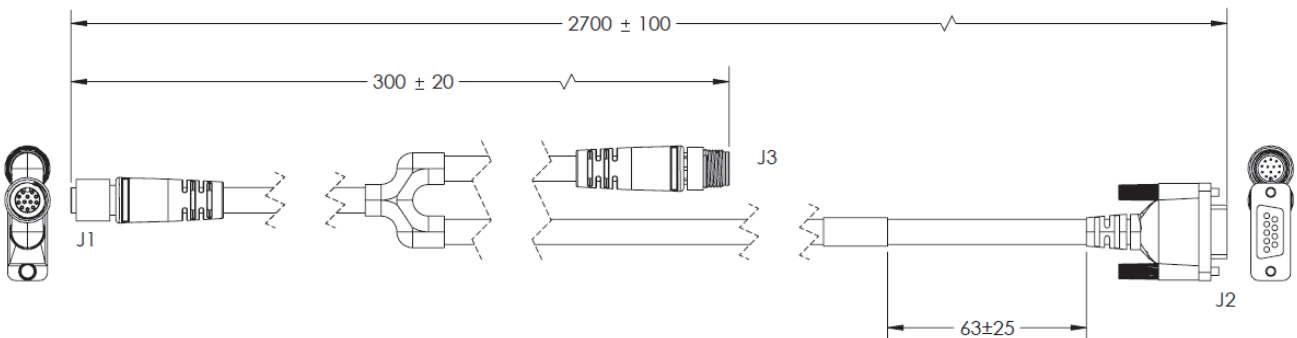
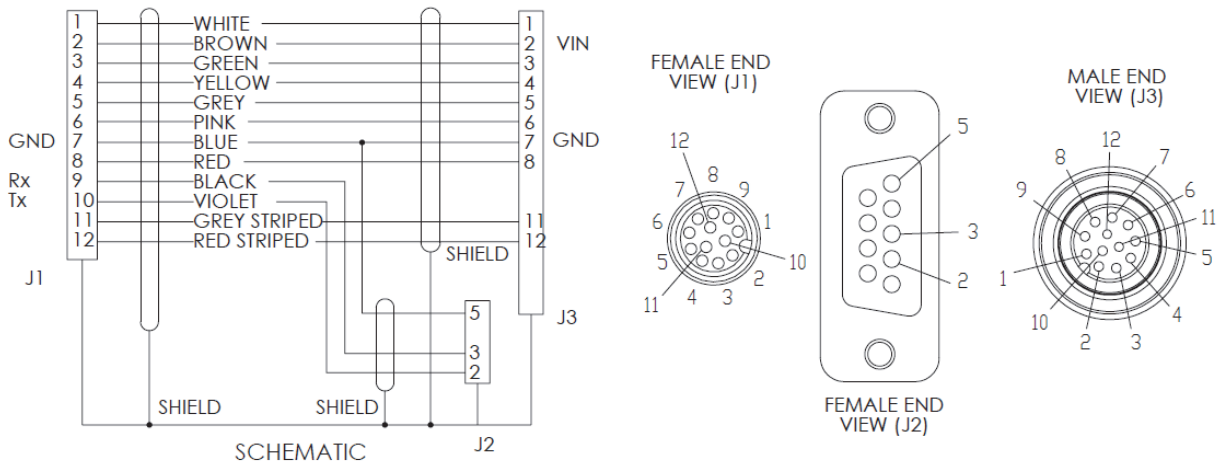

V430-WQK-3M – Camera to QX-1 Interconnect Cables with USB Keyboard Wedge Breakout – 2.7 M

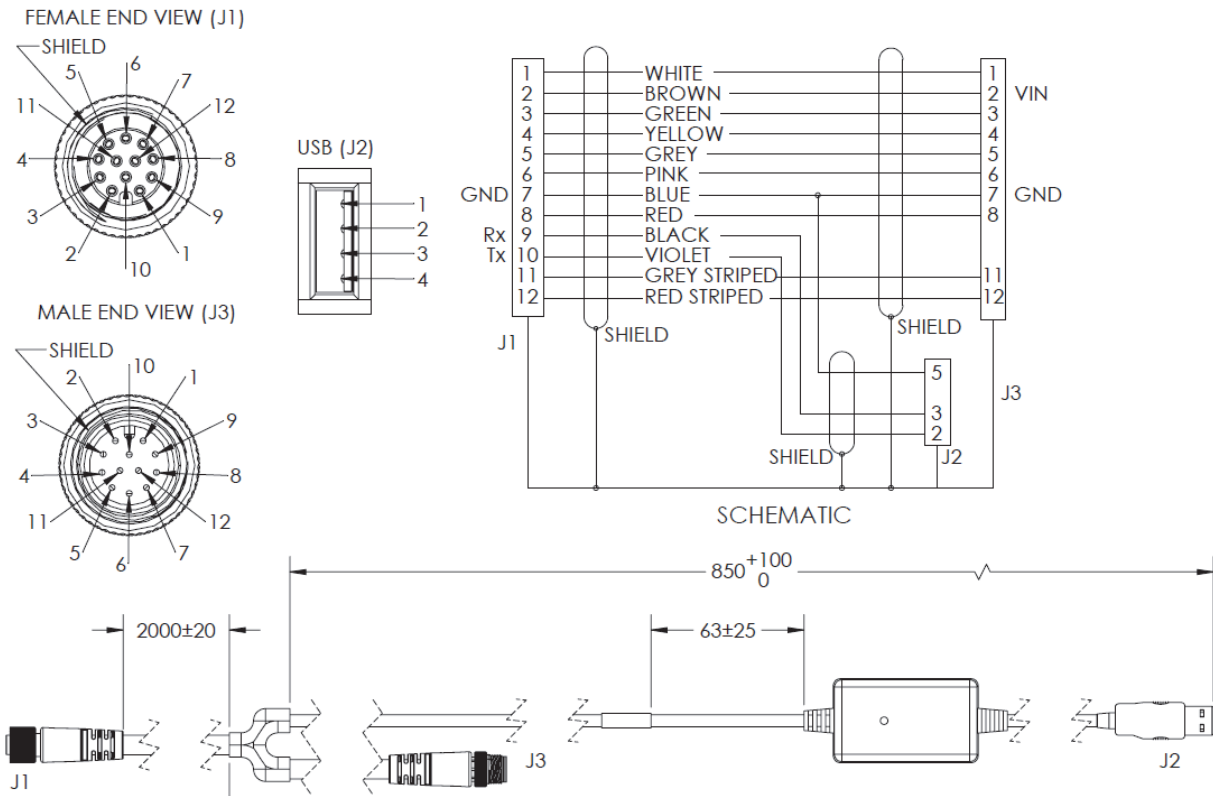

61-000148-03 – M12 12-Pin Plug to M12 12-Pin Socket, Right Angle, 3 M

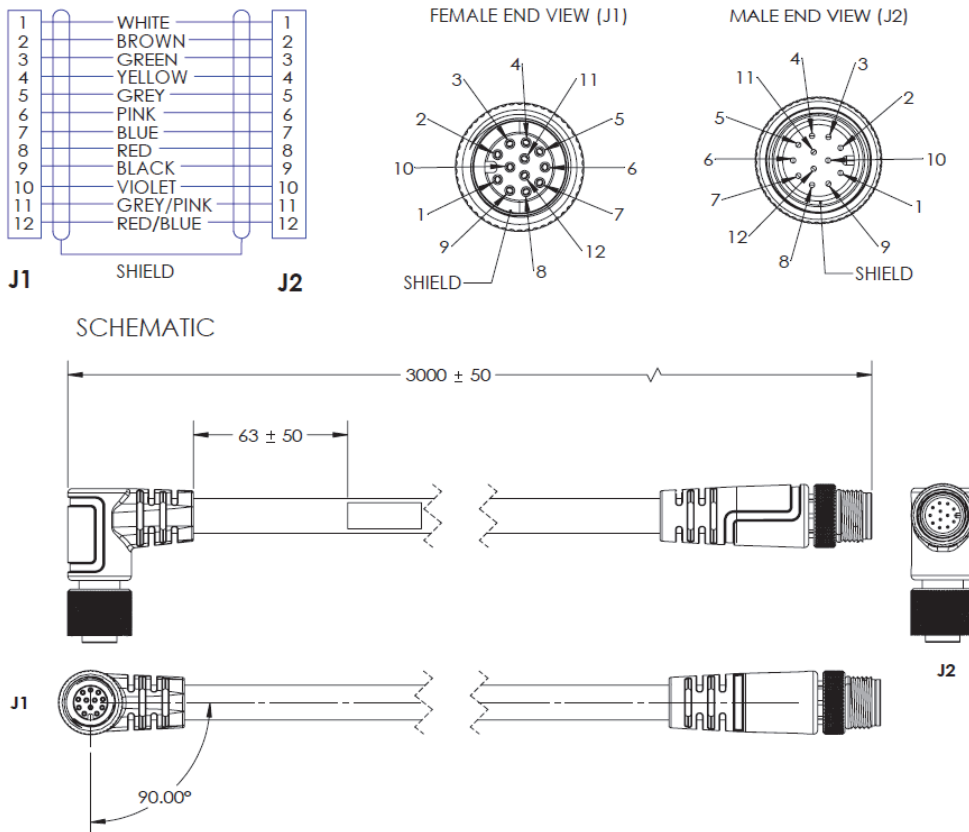

61-000148-04 – M12 12-Pin Plug to M12 12-Pin Socket, Right Angle, Alternate Key, 3 M

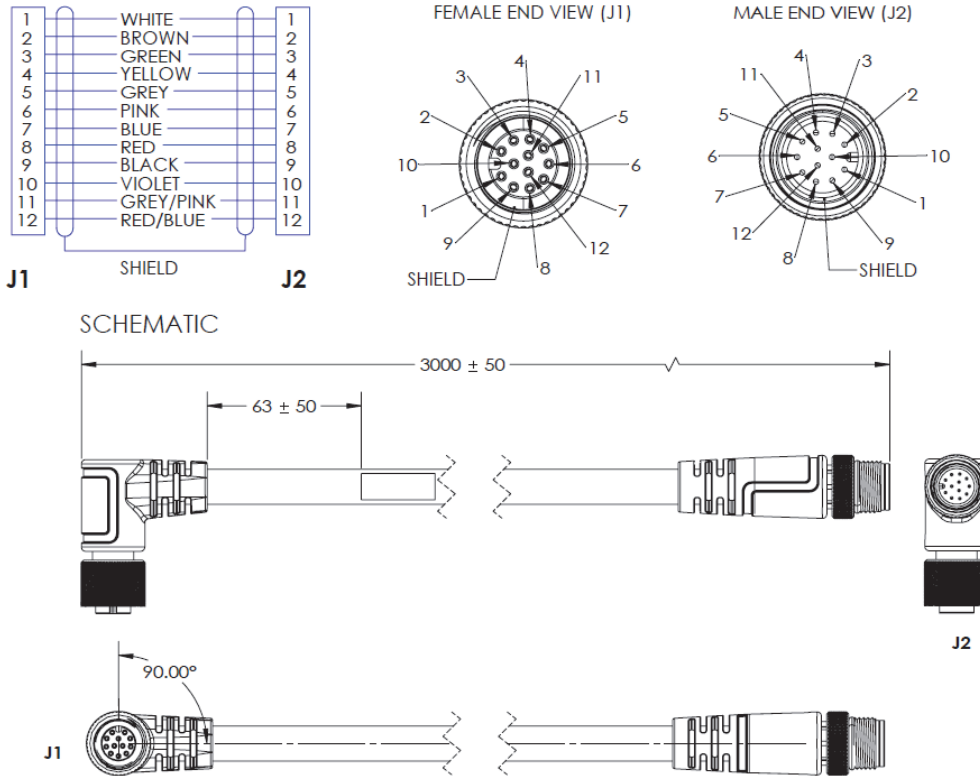

B

61-000162-03 – M12 12-Pin Plug to M12 12-Pin Socket, Right Angle, 1 M

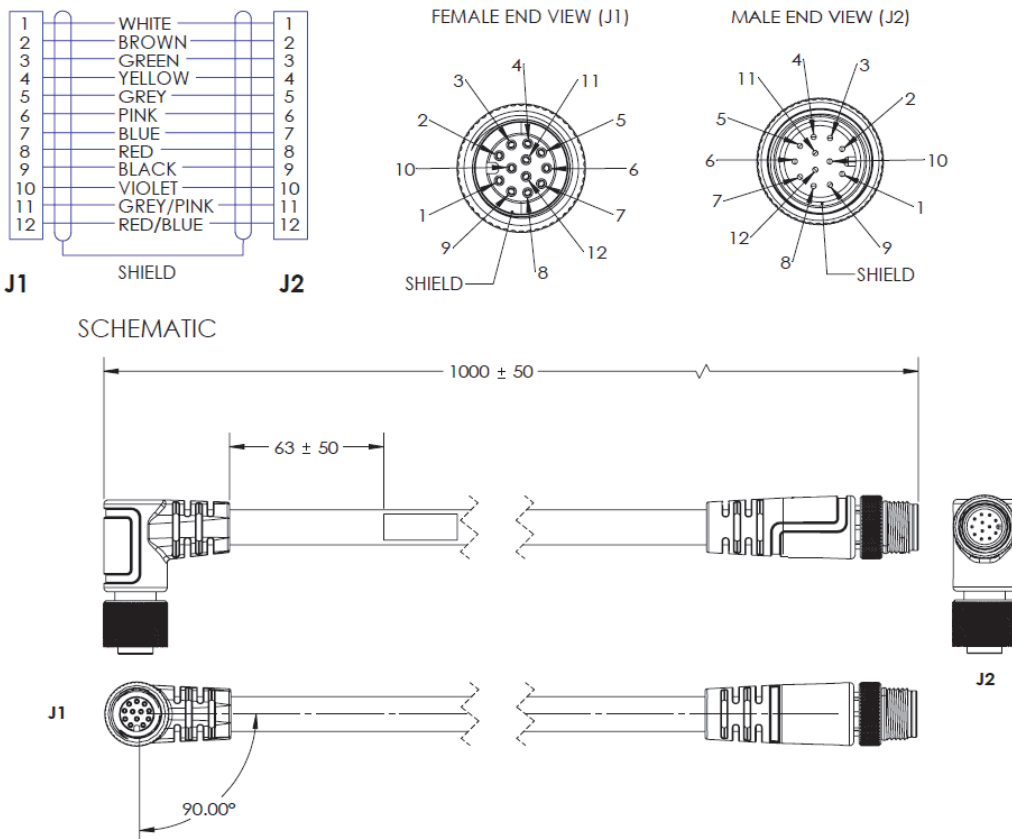

61-000162-04 – M12 12-Pin Plug to M12 12-Pin Socket, Right Angle, Alternate Key, 1 M

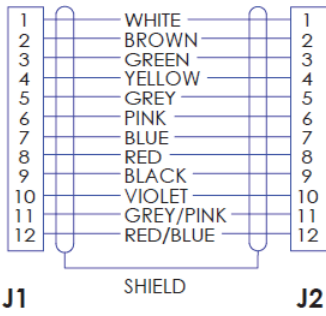

FEMALE END VIEW (J1)

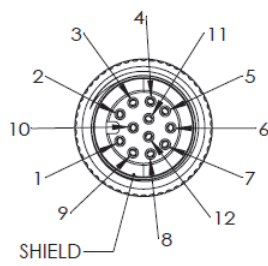

MALE END VIEW (J2)

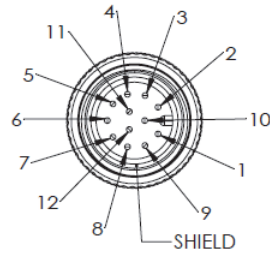

SCHEMATIC

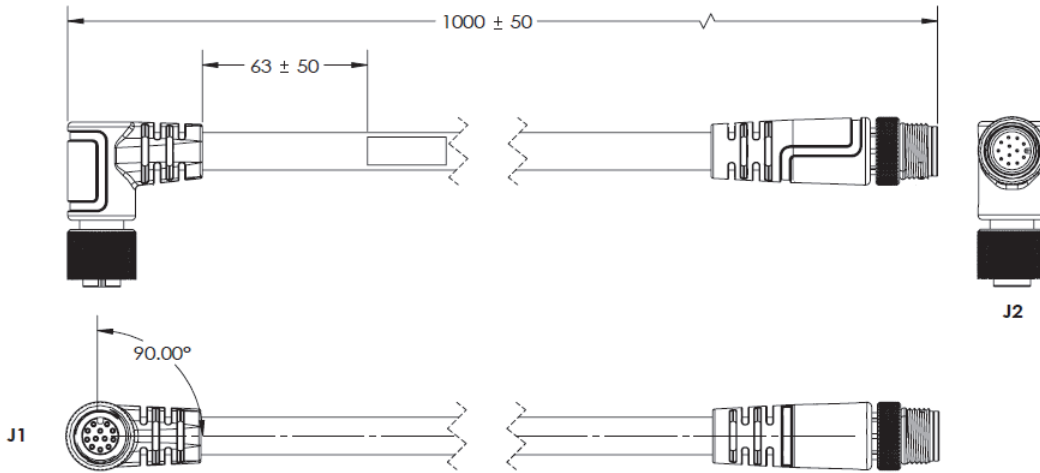

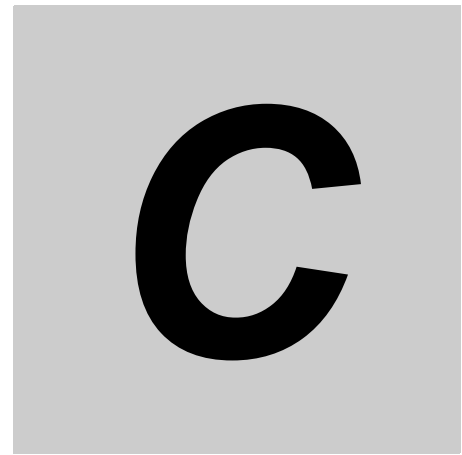

Appendix C - General Specifications

C

This section contains specifications for the MicroHAWK, F320-F, F330-F, F420-F, and F430-F Smart Cameras.

C-1	General Specifications	C-2
C-2	MicroHAWK Cable and Accessory Specifications	C-6

C-1 General Specifications

MicroHAWK F320-F

F320-F		F320-F□□□□03M-□□□	F320-F□□□□12M-□□□	F320-F□□□□50C-□□□
Symbologies *1	1D Symbologies	Code 39, Code 128, BC412, Interleaved 2 of 5, UPC/EAN, Codabar, Code 93, Pharmacode, PLANET, Postnet, Japanese Post, Australian Post, Royal Mail, Intelligent Mail, KIX		
	2D Symbologies	Data Matrix (ECC 0-200), QR Code, Micro QR Code, Aztec Code, DotCode, DMRE		
	Stacked Symbologies	PDF417, MicroPDF417, GS1 Databar (Composite and Stacked)		
Reading Performance *2	Number of Reading Digits	No Upper Limit (depending on bar width and reading distance)		
	Aiming Light	Two Blue LEDs		
	Illumination	Inner LEDs: Four White and Four Red (Wavelength: 625 nm)		
		Outer LEDs:	None	Outer LEDs: None
	Reading Distance / Field of View	Refer to <i>Field of View Charts</i> for details.		
	Pitch Angle (α) *3	±30°		
	Skew Angle (β) *3	±30°		
Tilt Angle (γ) *3	±180°			
Vision Tools	Locate, Decode, Optical Character Recognition (OCR), Count, Presence/Absence, Measure, Match String, String Format, Logic, Optical Character Verification (OCV), Symbol Quality Verification, Color Identification, Color Match			
Image Capture	Focus	Fixed Focus (Wide = 5.2 mm, Medium = 7.7 mm, Narrow = 16 mm)		
	Resolution	752 (H) x 480 (V)	1280 (H) x 960 (V)	2592 (H) x 1944 (V)
	Color / Monochrome	Monochrome CMOS	Monochrome CMOS	Color CMOS
	Shutter	Global Shutter	Global Shutter	Rolling Shutter
	Frames per Second	60 fps	42 fps	5 fps
	Exposure	50 to 66,667 μs	50 to 58,825 μs	50 to 66,667 μs
Image Logging	FTP			
Trigger	External Trigger (Edge or Level), Communication Trigger (Ethernet, RS-232C)			
I/O Specifications	Input Signals	Trigger Input: 5-28V rated (0.16 mA @ 5 VDC); Default: 3.3 V rated (0 mA @ 3.3 V)		
	Output Signals	One Signal (Strobe): 5 V TTL-compatible, can sink 10 mA and source 10 mA		
Communication	Connectivity	USB 2.0 Full-Speed (Ethernet over USB and HID), RS-232		
	Ethernet Specifications	100BASE-TX / 10BASE-T		
Indicator LEDs	PASS (Green), PWR (Green)			
Power Supply Voltage	5 VDC +/- 5%			
Current Consumption	450 mA at 5 VDC (max.)			
Environmental Immunity *4	Ambient Temperature Range	Operating: 0 to 40° C Storage: -50 to 75° C (No Icing or Condensation)		
	Ambient Humidity Range	Operating and Storage: 5% to 95% (Non-Condensing)		
	Ambient Atmosphere	No Corrosive Gases		
	Vibration Resistance (Destructive)	Oscillation Frequency: 10 to 150 Hz, Half Amplitude: 0.35 mm, Vibration Direction: X/Y/Z, Sweep Time: 8 minute/count, Sweep Count: 10 times		
	Shock Resistance (Destructive)	Impact Force: 150 m/s ² , Test Direction: 6 directions, three times each (up/down, front/back, left/right)		
	Degree of Protection	IEC 60529 IP40		
Weight	Main Body Only	59 g		
	Packaging Weight	Approx. 166 g (including packing)		
Dimensions	Main Body Dimensions	52 (W) x 39 (D) x 24 (H) mm		
	Packaging Dimensions	170 (W) x 117 (D) x 86 (H) mm		
Accessories	ReadMeFirst, CE Compliance Sheet			
LED Safety Standard	IEC 62471-1: 2006 Risk-Exempt Group			
Safety Standards	EN 61326-1:2013 FCC Part 15, Subpart B (Class B) UL60950-1 RCM, KC, EAC			
Materials	Case	Aluminum Diecast, Alumite (Black)		
	Reading Window	Acrylic		
Software	AutoVISION, Visionscape FrontRunner			

*1. These symbologies are supported based on Omron's read capability validation standard. Omron recommends that validation be performed for each application.

*2. Unless otherwise specified, reading performance is defined with center of field of view, angle R=∞.



*4. In an electrically noisy environment, use only the F430-F in combination with a noise filter cable (V430-W□F-□M) to ensure proper operation.

MicroHAWK F330-F

F330-F		F330-F□□□□03M-□□□	F330-F□□□□12M-□□□	F330-F□□□□50C-□□□
Symbologies *1	1D Symbologies	Code 39, Code 128, BC412, Interleaved 2 of 5, UPC/EAN, Codabar, Code 93, Pharmacoce, PLANET, Postnet, Japanese Post, Australian Post, Royal Mail, Intelligent Mail, KIX		
	2D Symbologies	Data Matrix (ECC 0-200), QR Code, Micro QR Code, Aztec Code, DotCode, DMRE		
	Stacked Symbologies	PDF417, MicroPDF417, GS1 Databar (Composite and Stacked)		
Reading Performance *2	Number of Reading Digits	No Upper Limit (depending on bar width and reading distance)		
	Aiming Light	Two Blue LEDs		
	Illumination	Inner LEDs: Four White and Four Red (Wavelength: 625 nm)		
		Outer LEDs: None	Outer LEDs: None	Outer LEDs: None
	Reading Distance / Field of View	Refer to <i>Field of View Charts</i> for details.		
	Pitch Angle (α) *3	±30°		
	Skew Angle (β) *3	±30°		
Tilt Angle (γ) *3	±180°			
Vision Tools		Locate, Decode, Optical Character Recognition (OCR), Count, Presence/Absence, Measure, Match Strings, String Format, Logic, Optical Character Verification (OCV), Symbol Quality Verification, Color Identification, Color Match		
Image Capture	Focus	Fixed Focus (Wide = 5.2 mm, Medium = 7.7 mm, Narrow = 16 mm)		
	Resolution	752 (H) x 480 (V)	1280 (H) x 960 (V)	2592 (H) x 1944 (V)
	Color / Monochrome	Monochrome CMOS	Monochrome CMOS	Color CMOS
	Shutter	Global Shutter	Global Shutter	Rolling Shutter
	Frames per Second	52 fps	40 fps	5 fps
	Exposure	50 to 66,667 μs	50 to 58,825 μs	50 to 66,667 μs
Image Logging		FTP		
Trigger		Communication Trigger (Ethernet)		
I/O Specifications	Input Signals	Ethernet		
	Output Signals	Ethernet		
Communication	Connectivity	Ethernet TCP/IP, EtherNet/IP, PROFINET		
	Ethernet Specifications	100BASE-TX / 10BASE-T		
Indicator LEDs		PASS (Green), PWR (Green)		
Power Supply Voltage		Source: 44-57 VDC IEEE802.3af POE		
Current Consumption		Max Current: 0.10 A		
Environmental Immunity *4	Ambient Temperature Range	Operating: 0 to 40° C Storage: -50 to 75°C (No Icing or Condensation)		
	Ambient Humidity Range	Operating and storage: 5% to 95% (Non-Condensing)		
	Ambient Atmosphere	No Corrosive Gases		
	Vibration Resistance (Destructive)	Oscillation Frequency: 10 to 150Hz, Half Amplitude: 0.35 mm, Vibration Direction: X/Y/Z, Sweep Time: 8 minute/count, Sweep Count: 10 times		
	Shock Resistance (Destructive)	Impact Force: 150 m/s2, Test Direction: 6 directions, three times each (up/down, front/back, left/right)		
	Degree of Protection	IEC 60529 IP40		
Weight	Main Body Only	72 g		
	Packaging Weight	Approx. 180 g (including packing)		
Dimensions	Main Body Dimensions	40 (W) x 63 (D) x 24 (H) mm		
	Packaging Dimensions	170 (W) x 117 (D) x 86 (H) mm		
Accessories		ReadMeFirst, CE Compliance Sheet		
LED Safety Standard		IEC 62471-1: 2006 Risk-Exempt Group		
Safety Standards		EN 61326-1:2013 FCC Part 15, Subpart B (Class B) UL60950-1 RCM, KC, EAC		
Materials	Case	Aluminum Diecast, Alumite (Black)		
	Reading Window	Acrylic		
Software		AutoVISION, Visionscape FrontRunner		

*1. These symbologies are supported based on Omron's read capability validation standard. Omron recommends that validation be performed for each application.

*2. Unless otherwise specified, reading performance is defined with center of field of view, angle R=∞.



*4. In an electrically noisy environment, use only the F430-F in combination with a noise filter cable (V430-W□F-□M) to ensure proper operation.

MicroHAWK F420-F

F420-F		F420-F□□□□03M-□□□	F420-F□□□□12M-□□□	F420-F□□□□50C-□□□
Symbolologies *1	1D Symbolologies	Code 39, Code 128, BC412, Interleaved 2 of 5, UPC/EAN, Codabar, Code 93, Pharmacode, PLANET, Postnet, Japanese Post, Australian Post, Royal Mail, Intelligent Mail, KIX		
	2D Symbolologies	Data Matrix (ECC 0-200), QR Code, Micro QR Code, Aztec Code, DotCode, DMRE		
	Stacked Symbolologies	PDF417, MicroPDF417, GS1 Databar (Composite and Stacked)		
Reading Performance *2	Number of Reading Digits	No Upper Limit (depending on bar width and reading distance)		
	Aiming Light	Two Blue LEDs		
	Illumination	Inner LEDs: Four White and Four Red (Wavelength: 625 nm)		
		Outer LEDs:	8 Red or White	8 Red or White
	Reading Distance / Field of View	Refer to <i>Field of View Charts</i> for details.		
	Pitch Angle (α) *3	$\pm 30^\circ$		
	Skew Angle (β) *3	$\pm 30^\circ$		
Tilt Angle (γ) *3	$\pm 180^\circ$			
Vision Tools		Locate, Decode, Optical Character Recognition (OCR), Count, Presence/Absence, Measure, Match Strings, String Format, Logic, Optical Character Verification (OCV), Symbol Quality Verification, Color Identification, Color Match		
Image Capture	Focus	Liquid Lens Autofocus or Fixed Focus (Wide = 5.2 mm, Medium = 7.7 mm, Narrow = 16 mm, L = 16 mm)		
	Resolution	752 (H) x 480 (V)	1280 (H) x 960 (V)	2592 (H) x 1944 (V)
	Color / Monochrome	Monochrome CMOS	Monochrome CMOS	Color CMOS
	Shutter	Global Shutter	Global Shutter	Rolling Shutter
	Frames per Second	52 fps	40 fps	5 fps
	Exposure	50 to 66,667 μ s	50 to 58,825 μ s	50 to 66,667 μ s
Image Logging		FTP		
Trigger		External Trigger (Edge or Level), Communication Trigger (Ethernet, RS-232C)		
I/O Specifications	Input Signals	Trigger Input: 5-28 V rated (0.16 mA @ 5 VDC); New Master: 5 to 28 V rated (0.16 mA @ 5 VDC); Default: 3.3 V rated (0 mA @ 3.3 V)		
	Output Signals	3 Signals : 5 V TTL-compatible, can sink 10 mA and source 10 mA		
Communication	Connectivity	RS-232C, USB 2.0 High Speed, Ethernet over USB/HID		
	Ethernet Specifications	100BASE-TX / 10BASE-T		
Indicator LEDs		PASS (Green), TRIG (Amber), MODE (Amber), LINK (Amber), FAIL (Red), PWR (Green)		
Power Supply Voltage		5 VDC +/- 5%		
Current Consumption		650 mA at 5 VDC (max.)		
Environmental Immunity *4	Ambient Temperature Range	Operating: 0 to 45° C Storage: -50 to 75° C (No Icing or Condensation)		
	Ambient Humidity Range	Operating and storage: 5% to 95% (Non-Condensing)		
	Ambient Atmosphere	No Corrosive Gases		
	Vibration Resistance (Destructive)	Sine Vibration: 10 Hz to 55 Hz, 0.35mm displacement, 20 cycles/axis. Random Vibration: 20 Hz to 2000 Hz, 6.295 Grms, 30 min/axis		
	Shock Resistance (Destructive)	50 G, 11 ms, sawtooth profile. 3X in each X, Y, Z axis.		
	Degree of Protection	IEC 60529 IP54		
Weight	Main Body Only	120 g		
	Packaging Weight	Approx. 230 g (including packing)		
Dimensions	Main Body Dimensions	44.5 (W) x 38.1 (D) x 25.4 (H) mm		
	Packaging Dimensions	170 (W) x 117 (D) x 86 (H) mm		
Accessories		ReadMeFirst, CE Compliance Sheet		
LED Safety Standard		IEC 62471-1: 2006 Risk-Exempt Group		
Safety Standards		EN 61326-1:2013 FCC Part 15, Subpart B (Class B) UL60950-1 RCM, KC, EAC		
Materials	Case	Aluminum Diecast, Alumite (Black)		
	Reading Window	Acrylic		
Software		AutoVISION, Visionscape FrontRunner		

*1. These symbolologies are supported based on Omron's read capability validation standard. Omron recommends that validation be performed for each application.
 *2. Unless otherwise specified, reading performance is defined with center of field of view, angle $R = \infty$.



*4. In an electrically noisy environment, use only the F430-F in combination with a noise filter cable (V430-W□F-□M) to ensure proper operation.

MicroHAWK F430-F

F430-F		F430-F□□□□03M-□□□	F430-F□□□□12M-□□□	F430-F□□□□50C-□□□
Symbologies *1	1D Symbologies	Code 39, Code 128, BC412, Interleaved 2 of 5, UPC/EAN, Codabar, Code 93, Pharmacode, PLANET, Postnet, Japanese Post, Australian Post, Royal Mail, Intelligent Mail, KIX		
	2D Symbologies	Data Matrix (ECC 0-200), QR Code, Micro QR Code, Aztec Code, DotCode, DMRE		
	Stacked Symbologies	PDF417, MicroPDF417, GS1 Databar (Composite and Stacked)		
Reading Performance *2	Number of Reading Digits	No Upper Limit (depending on bar width and reading distance)		
	Aiming Light	Two Blue LEDs		
	Illumination	Inner LEDs: Four White and Four Red (Wavelength: 625 nm)		
		Outer LEDs: 8 Red or White	Outer LEDs: 8 Red or White; 24 Red or White for F430-F□□□□12M-R□□	Outer LEDs: 8 White
	Reading Distance / Field of View	Refer to <i>Field of View Charts</i> for details.		
	Pitch Angle (α) *3	±30°		
	Skew Angle (β) *3	±30°		
Tilt Angle (γ) *3	±180°			
Vision Tools	Locate, Decode, Optical Character Recognition (OCR), Count, Presence/Absence, Measure, Match String, String Format, Logic, Optical Character Verification (OCV), Symbol Quality Verification, Color Identification, Color Match			
Image Capture	Focus	Liquid Lens Autofocus or Fixed Focus (Wide = 5.2 mm, Medium = 7.7 mm, Narrow = 16 mm, L = 16 mm)		
	Resolution	752 (H) x 480 (V)	1280 (H) x 960 (V)	2592 (H) x 1944 (V)
	Color / Monochrome	Monochrome CMOS	Monochrome CMOS	Color CMOS
	Shutter	Global Shutter	Global Shutter	Rolling Shutter
	Frames per Second	52 fps	40 fps	5 fps
	Exposure	50 to 66,667 μs	50 to 58,825 μs	50 to 66,667 μs
Image Logging	FTP			
Trigger	External Trigger (Edge or Level), Communication Trigger (Ethernet, RS-232C)			
I/O Specifications	Input Signals	Trigger Input; New Master: Bi-Directional, Optoisolated, 4.5-28 V rated (10 mA @ 28 VDC)		
	Output Signals	3 Signals : Bi-Directional, Optoisolated, 1-28 V rated, (ICE < 100 mA at 24 VDC, current limited by user)		
Communication	Connectivity	RS-232C, Ethernet TCP/IP, EtherNet/IP, PROFINET		
	Ethernet Specifications	100BASE-TX / 10BASE-T		
Indicator LEDs	PASS (Green), TRIG (Amber), MODE (Amber), LINK (Amber), FAIL (Red), PWR (Green)			
Power Supply Voltage	DC24V (Ambient Voltage Range: DC10~30V) *5			
Current Consumption	0.18 A at 24 VDC (max.)			
Environmental Immunity *4	Ambient Temperature Range	Operating: 0 to 45° C Storage: -50 to 75° C (No Icing or Condensation)		
	Ambient Humidity Range	Operating and storage: 5% to 95% (Non-Condensing)		
	Ambient Atmosphere	No Corrosive Gases		
	Vibration Resistance (Destructive)	Sine Vibration: 10 Hz to 55 Hz, 0.35 mm displacement, 20 cycles/axis. Random Vibration: 20 Hz to 2000 Hz, 6.295 Grms, 30 min/axis		
	Shock Resistance (Destructive)	50 G, 11 ms, sawtooth profile. 3X in each X, Y, Z axis		
	Degree of Protection	IEC 60529 IP65 and IP67		
Weight	Main Body Only	Approx. 68 g		
	Packaging Weight	Approx. 174 g (including packing)		
Dimensions	Main Body Dimensions	44.5 (W) x 44.5 (D) x 25.4 (H) mm		
	Packaging Dimensions	170 (W) x 117 (D) x 86 (H) mm		
Accessories	ReadMeFirst, CE Compliance Sheet			
LED Safety Standard	IEC 62471-1: 2006 Risk-Exempt Group			
Safety Standards	EN 61326-1:2013 FCC Part 15, Subpart B (Class B) UL60950-1 RCM, KC, EAC			
Materials	Case	Aluminum Diecast, Alumite (Black)		
	Reading Window	Acrylic		
Software	AutoVISION, Visionscape FrontRunner			

*1. These symbologies are supported based on Omron's read capability validation standard. Omron recommends that validation be performed for each application.
*2. Unless otherwise specified, reading performance is defined with center of field of view, angle R=∞.



*4. In an electrically noisy environment, use only the F430-F in combination with a noise filter cable (V430-W□F-□M) to ensure proper operation.

*5. UL certification rating is DC24V. Maximum ripple is 200 mV p-p.

C-2 MicroHAWK Cable and Accessory Specifications

MicroHAWK Cable Specifications

Item	V430-W8- M	V430-W- F- M	V430-WQ- M	V430-WE- M
Cable Type	Robot cable	Robot cable. Overmolded filter must be protected from flexing	Robot cable	Robot cable
Connector Type	Straight LD: Right Angle Down LU: Right Angle Up	Straight LD: Right Angle Down LU: Right Angle Up	Straight	Straight LD: Right Angle Down LU: Right Angle Up
Category	I/O			Ethernet
Size	AWG24			AWG24
Outer Diameter	7.11mm			7.37mm
Min. Bending Radius	53mm			73.7mm
Usage Environment	Ambient Temperature Range	Operating: 0-45C Storage: -50 to 75C (No Icing or Condensation)		
	Ambient Humidity Range	5-95% (Non-Condensing)		
	Ambient Atmosphere	No Corrosive Gases		
	Vibration Tolerance	Oscillation Frequency: 10 to 150Hz, Half Amplitude: 0.35 mm, Vibration Direction: X/Y/Z, Sweep Time: 8 minute/count, Sweep Count: 10 times		
	Shock Resistance	Impact Force: 150 m/s ² , Test Direction: 6 directions, three times each (up/down, front/back, left/right)		
Material	Connector Overmold: Thermoplastic Polyamide, Cable Jacket: Polyurethane			
Weight	V430-W8-3M: 259g V430-W8-5M: 422g V430-W8LD-3M: 253g V430-W8LU-3M: 253g	V430-WQF-1M: 79g V430-W8F-3M: 285g V430-W8F-5M: 447g V430-W8LDF-3M: 278g V430-W8LUF-3M: 278g	V430-WQ-1M: 109g V430-WQ-3M: 272g V430-WQ-5M: 351g	V430-WE-1M: 94g V430-WE-3M: 215g V430-WE-5M: 352g V430-WELD-3M: 218g V430-WELU-3M: 218g

Item	61-000151-01	
Cable Type	Static use cable	
Connector Type	Straight	
Category	I/O	
Size	AWG22	
Outer Diameter	5.82mm	
Min. Bending Radius	63.5mm	
Usage Environment	Ambient Temperature Range	Operating: 0-45C Storage: -50 to 75C (No Icing or Condensation)
	Ambient Humidity Range	5-95% (Non-Condensing)
	Ambient Atmosphere	No Corrosive Gases
	Vibration Tolerance	Oscillation Frequency: 10 to 150Hz, Half Amplitude: 0.35 mm, Vibration Direction: X/Y/Z, Sweep Time: 8 minute/count, Sweep Count: 10 times
	Shock Resistance	Impact Force: 150 m/s ² , Test Direction: 6 directions, three times each (up/down, front/back, left/right)
Material	Connector Housing: Nylon, Cable Jacket: PVC	
Weight	67g	

MicroHAWK Cable Specifications (continued)

Item	V430-WQR-3M	V430-WR-_M	V430-WQK-3M
Cable Type	Robot cable. "Y" must be produced from flexing	Robot cable	Robot cable (2M long section only). Protect "Y" from flexing.
Connector Type	Straight		
Category	I/O and RS232		Keyboard Wedge
Size	AWG24		
Outer Diameter	7.11mm		
Min. Bending Radius	53mm		
Usage Environment	Ambient Temperature Range	Operating: 0-45C Storage: -50 to 75C (No Icing or Condensation)	
	Ambient Humidity Range	5-95% (Non-Condensing)	
	Ambient Atmosphere	No Corrosive Gases	
	Vibration Tolerance	Oscillation Frequency: 10 to 150Hz, Half Amplitude: 0.35 mm, Vibration Direction: X/Y/Z, Sweep Time: 8 minute/count, Sweep Count: 10 times	
	Shock Resistance	Impact Force: 150 m/s ² , Test Direction: 6 directions, three times each (up/down, front/back, left/right)	
Material	Connector Overmold: Thermoplastic Polyamide, Cable Jacket: Polyurethane		
Weight	273g	V430-WR-1M: 107g V430-WR-3M: 276g	270g

Item	V420-WUB-1M	V420-WUX-1M	V420-WRX-1M	V420-WU8X-1M	V420-WRU8X-1M
Cable Type	Static use cable.				
Connector Type	Straight				
Category	USB & USB/RS232 W/ External Power				
Size	AWG24			AWG26	
Outer Diameter	4.5mm	5mm		4.7mm	
Min. Bending Radius	45mm	4.8mm	47mm		
Usage Environment	Ambient Temperature Range	Operating: 0-45C Storage: -50 to 75C (No Icing or Condensation)			
	Ambient Humidity Range	5-95% (Non-Condensing)			
	Ambient Atmosphere	No Corrosive Gases			
	Vibration Tolerance	Oscillation Frequency: 10 to 150Hz, Half Amplitude: 0.35 mm, Vibration Direction: X/Y/Z, Sweep Time: 8 minute/count, Sweep Count: 10 times			
	Shock Resistance	Impact Force: 150 m/s ² , Test Direction: 6 directions, three times each (up/down, front/back, left/right)			
Material	PVC	Connector Shell/Overmold: Thermoplastic UL94 V-0, Cable Jacket: PVC			
Weight	55g	55g	94g	125g	155g



MicroHAWK Cable Specifications (continued)

Item		V320-W8□□-_M	V320-WR□□-_M
Cable Type		Static use cable.	
Connector Type		Straight	
Category		I/O, Power, Communication	
Size		AWG24	
Outer Diameter		5mm	
Min. Bending Radius		4.8mm	
Usage Environment	Ambient Temperature Range	Operating: 0-40C Storage: -50-75C (No Icing or Condensation)	
	Ambient Humidity Range	5-95% (Non-Condensing)	
	Ambient Atmosphere	No Corrosive Gases	
	Vibration Tolerance	Oscillation Frequency: 10 to 150Hz, Half Amplitude: 0.35 mm, Vibration Direction: X/Y/Z, Sweep Time: 8 minute/count, Sweep Count: 10 times	
	Shock Resistance	Impact Force: 150 m/s ² , Test Direction: 6 directions, three times each (up/down, front/back, left/right)	
Material		Connector Shell/Overmold: Thermoplastic UL94 V-0, Cable Jacket: PVC	
Weight		V320-W8-3M: 44g V320-W8LR-3M: 44g	V320-WRX-2M: 78g V320-WRXLR-2M: 78g V320-WR-1M: 60g V320-WRLR-1m: 60g

Item		V430-AF0	V430-AF1	V430-AF2	V430-AF3	V430-AF4	V430-AF5
Filter Type		Clear Window	Diffuser	Polarizer	Right Angle Mirror	YAG Laser	ESD Window Resistivity ≤ 1.0 X 10 ⁹ OHMS/SQ
Usage Environment	Ambient Temperature Range	Operating: 0-45C Storage: -50 to 75C (No Icing or Condensation)					
	Ambient Humidity Range	5-95% (Non-Condensing)					
	Ambient Atmosphere	No Corrosive Gases					
	Vibration Tolerance	Oscillation Frequency: 10 to 150Hz, Half Amplitude: 0.35 mm, Vibration Direction: X/Y/Z, Sweep Time: 8 minute/count, Sweep Count: 10 times			Note 1	Oscillation Frequency: 10 to 150Hz, Half Amplitude: 0.35 mm, Vibration Direction: X/Y/Z, Sweep Time: 8 minute/count, Sweep Count: 10 times	
	Shock Resistance	Impact Force: 150 m/s ² , Test Direction: 6 directions, three times each (up/down, front/back, left/right)				Impact Force: 150 m/s ² , Test Direction: 6 directions, three times each (up/down, front/back, left/right)	
Material		Acrylic	Polyester	Polymer Film	Bracket: Aluminum Mirror: Soda Lime Glass	Acrylic	Acrylic
Weight		3.4g	3.6g	3.6g	36.3g	8g	3.4g

Note 1: Test data not available. Customer to evaluate for given installation.

MicroHAWK Accessory Specifications

Item	V430-AF6	V430-AF7	V430-AF0R	V430-AF1R	V430-AF2R	V330-AF1	V330-AF2
Filter Type	Red Light	Blue Light	Clear Window	Diffuser	Polarizer	Diffuser	Polarizer
Usage Environment	Operating: 0-45C Storage: -50 to 75C (No Icing or Condensation)					Operating: 0-40C Storage: -50 to 75C (No Icing or Condensation)	
	Ambient Humidity Range: 5-95% (Non-Condensing)						
	Ambient Atmosphere: No Corrosive Gases						
	Vibration Tolerance: Oscillation Frequency: 10 to 150Hz, Half Amplitude: 0.35 mm, Vibration Direction: X/Y/Z, Sweep Time: 8 minute/count, Sweep Count: 10 times						
	Shock Resistance: Impact Force: 150 m/s ² , Test Direction: 6 directions, three times each (up/down, front/back, left/right)						
Material	Acrylic	Acrylic	Acrylic	Acrylic	Polymer Film	Polyester	Polymer Film
Weight	3.4g	3.4g	10g	10g	10g	0.12g	0.25g

Item	V430-ALR	V430-ALW	V430-ALB	V430-ALI	V430-ALRR	V430-ALWR	V430-ALBR	V430-ALIR
Light Type	Red	White	Blue	IR	Red	White	Blue	IR
Usage Environment	Operating: 0-45C Storage: -50 to 75C (No Icing or Condensation)							
	Ambient Humidity Range: 5-95% (Non-Condensing)							
	Ambient Atmosphere: No Corrosive Gases							
	Vibration Tolerance: Oscillation Frequency: 10 to 150Hz, Half Amplitude: 0.35 mm, Vibration Direction: X/Y/Z,							
	Shock Resistance: Impact Force: 150 m/s ² , Test Direction: 6 directions, three times each (up/down,							
Weight	1g	1g	1g	1g	3g	3g	3g	3g

Item	V430-AM0	V430-AM1	V430-AM2	V430-AM3	V430-AM4	V430-AM5	V430-AM6	V430-AM7
Mount Type	L Bracket	1/4"-20 Mount	4" Ram Mount	APG Mount	Isolation Mount	Adapter MS4 to F/V4X0	Bracket, Smart Ring to F/V4X0	Bracket, QX-Hawk to F/V4X0, Isolated
Usage Environment	Operating: 0-45C Storage: -50 to 75C (No Icing or Condensation)							
	Ambient Humidity Range: 5-95% (Non-Condensing)							
	Ambient Atmosphere: No Corrosive Gases							
	Vibration Tolerance: Note 1							
	Shock Tolerance: Note 1							
Material	Stainless Steel w/ Stainless Steel Fasteners	Aluminum w/ Stainless Steel Fasteners	Aluminum, Rubber w/ Stainless Steel Fasteners	Stainless Steel w/ Stainless Steel Fasteners	Nylon	Aluminum w/ Stainless Steel Fasteners	Aluminum w/ Stainless Steel Fasteners	Nylon w/ Nylon and Stainless Steel Fasteners
Weight	139g	20g	113g	232g	2g	20g	27g	30g

Note 1: Test data not available. Customer to evaluate for given installation.

MicroHAWK Accessory Specifications (continued)

Item	97-9000006-01	97-000011-02	97-000012-01	V330-AP1
Compatible models	V420/F420/V320/F320		V430/F430	V330/F330
Power Supply Type	5V Power Supply, 5.5mm x 2.5mm Barrel Connector	5V Power Supply, 2 Pole Locking DIN Connector	5V Power Supply, 12 Pole M12 Socket	56V Single Port POE Injector (IEEE802.3at Compliant)
AC Plug Shape	A/C/G	B/E	B/E	—
Input Voltage	AC100V-240V			
Output Voltage	DC5V	DC5V	DC24V	DC56V
Maximum Output Current	2A	4A	2.1A	0.5A
Usage Environment	Ambient Temperature Range	Operating: 0-50C Storage: -10-55C (No Icing or Condensation)	Operating: 0-40C Storage: -20-80C (No Icing or Condensation)	Operating: 0-40C Storage: -20-80C (No Icing or Condensation)
	Ambient Humidity Range	5-90%	20-80%	20-80%
	Ambient Atmosphere	No Corrosive Gases		
	Vibration Tolerance	Note 1		
	Shock Tolerance	Note 1		
Power Supply Manufacturer	Mega Electronics Inc.			Phihong
Safety Standards	UL, CCC, CE, RCM, PSE, KC, EAC	UL, CCC, CE, RCM, PSE, KC, EAC, BSMI	UL, CCC, CE, RCM, PSE, KC, EAC, BSMI	UL, CB, CCC, BSMI, CU (EAC), IRAM (TUV-s), CE, RCM, NOM/NYCE, PSB, KC+KCC, EAC
Weight	100g	170g	258g	234g

Item	V420-AC0	V420-AC1	V420-AC2
Contents	Power Supply	97-9000006-01	97-000011-02
	Cable	V420-WRX-1M	V420-WUX-1M
Weight	349g	329g	851g

Note 1: Test data not available. Customer to evaluate for given installation.



Appendix D - Serial Commands

Serial commands can be sent via TCP port, AutoVISION Terminal, or HyperTerminal.

D-1	Serial Commands	D-2
-----	-----------------------	-----

D-1 Serial Commands

Serial Command Syntax

< > = Required argument. Replace appropriately.

For example:

-u <DB_User_name> becomes -u av where av replaces DB_User_name.

| = Mutually exclusive arguments. Choose one from the list.

{ } = Used with | to specify a list of choices for an argument.

[] = Optional parameter.

Important: Unless otherwise stated, commands will respond with **!OK** on success and **!ERROR** on failure.

AUTOCAL [-exp={0|1}] [-expval={60-100000}] [-gain={0|1}] [-gainval={0-100}] [-focus={0|1}] [-focval{0-9999}]

Initiates camera calibration of gain, exposure, and focus. Each parameter is independent. Ranges are device-dependent.

-exp enable=1 or disable=0 autocalibrate exposure.

-expval value of exposure in μ s.

-gain enable=1 or disable=0 autocalibrate gain.

-gainval value of gain in percentage.

-focus enable=1 or disable=0 autocalibrate focus

-focval value of focus in mm.

Example 1:

Command: AUTOCAL

Response: 0;4632;134;50;300 (gain=0, exposure=4632 μ s, focus=134, min allowable focus=50, max allowable focus=300)

Example 2:

Command: OFFLINE

Response: !OK

Command: QUERYAUTOCAL

Response: 0;4632;134;50;300 (Gain was 0.)

Command: AUTOCAL -exp=1 -gain=0 -gainval=18 (Fixed gain at 18%.)

Response: 18;3308;128;50;300 (Gain did not change and exposure has changed from 4632 μ s to 3308 μ s.)

Example 3:

Command: OFFLINE

Response: !OK

Command: QUERYAUTOCAL

Response: 0;3478;226;50;300 (Exposure was 3478 μ s.)

Command: AUTOCAL -exp=0 -expval=1000 (Fixed exposure at 1000 μ s.)

Response: 31;1000;98;50;300 (Exposure stayed at 1000 μ s and gain has changed from 0% to 31%.)

Important: AUTOCAL only functions when the camera is OFFLINE.

GET {tagname|service|service.tagname}

Gets value of a global tag.

The tagname must correspond to one of the supported tags within the device. Use the **INFO** command to get a full list of tags and services, as well as attributes of the tag and list of subtags.

The command is terminated by a carriage return and/or line feed character.

Include an index to get a single value from an array such as **GET int1**. If the index is omitted, the full array of values will be returned in a comma-separated list of values.

Send **Get {tagname|service.tagname|service}** to get the value of a tag within the global data service. To get the value of a tag within another service, prefix the tagname with the service name. For example, a **GET <service.tagname>** command such as **GET eip.input** for the EIP input assembly.

The AVP service allows retrieval of step and datum information from the job tree using forward slash '/' in the symbolic name path. **GET avp/insp1/snapshot1/status** paths are not case-sensitive and do not need to be fully qualified if unique.

GET avp/snapshot1/status will return the same result if there is only one inspection.

When issued against a step, **GET avp/snapshot1** will return the values for all datums.

Success Return: On success will return the value stored in the tag.

For example: ABCD

Fail Return: On failure will return !ERROR followed by the reason for the failure.

For example: !ERROR Tag matchstring66 not found

Important: This command only functions when the camera is ONLINE.

For TCP Connection:

GETIMAGE [-format={jpg|png|tif|raw}] [-quality ={0-100}] [-woi=left,top,right,bottom] [-inspection=n]

For UART Connection:

GETIMAGE <-transfer=y modem> [-format={jpg|png}] [-quality ={0-100}] [-woi=left,top,right,bottom] [-inspection=n]

Initiates serial transfer of inspection image.

Note: This command always returns the last (most recent) image.

-transfer=y modem uses Ymodem protocol over the serial port. If the **-transfer** option is omitted completely, the transfer mode is over the TCP and Ethernet port.

Important: YModem transfer option is not supported on the HAWK MV-4000.

-format={jpg|png|raw|tif} specifies the format of the image. **RAW** and **TIF** are not supported over a UART Connection. If omitted, the image format is **JPG**.

Note: For monochrome cameras, the only formats available are TIF, PNG, and JPG. For color cameras, the only formats available are RAW, and PNG.

Note: All image file types return complete file information that can be saved directly to disk except the RAW file type, which requires explicit conversion.

-quality=n specifies a JPG compression quality of n less than or equal to 100. The default quality is 80 if not specified. This setting is only supported for the JPG file type.

Note: PNG, RAW, and TIF formats provide lossless image compression. If format is set to PNG, RAW, or TIF, the quality setting does not apply.

-woi=left,top,right,bottom specifies a rectangular area of the image to be included in the output image. If omitted, the full image buffer is returned.

Note: **-woi** is only supported for TIF and JPG formats, as shown in the table below.

	Color Full Image	Color WOI	Mono Full Image	Mono WOI
PNG	Y	N	Y	N
RAW	Y	N	Y	N
TIF	Y	Y	Y	Y
JPG	Y	Y	Y	Y

-inspection=n specifies the inspection from which to retrieve an image. The image will be from the first snapshot within that inspection. If not specified, the image will be from the first inspection that contains a snapshot.

The following example will retrieve an image from the camera with these settings: **Protocol:** ymodem; **Format:** png; **Quality:** N/A; **Inspection:** second inspection.

GETIMAGE -transfer=y modem -format=png -inspection=2

The following example will retrieve an image from the camera with these settings: **Protocol:** ymodem; **Format:** jpg (default); **Quality:** 50; **Inspection:** first inspection (default).

GETIMAGE -transfer=y modem -quality=50

Important: This command only functions when the camera is ONLINE.

HELP

Returns a list of all serial commands showing correct syntax and functionality descriptions.

INFO [tagname|service]

Gets information about a tag or service.

INFO with no arguments gets a list of services.

INFO <service> gets a list of tags in that service.

INFO <service.tagname> gets attributes of the tag as well as a list of subtags.

The AVP service allows retrieval of step and datum information from the job tree using forward slash '/' in the symbolic name path. **INFO avp/insp1/snapshot1/status** paths are not case-sensitive and do not need to be fully qualified if unique.

INFO avp/snapshot1/status will return the same result if there is only one inspection.

When issued against a step, **INFO avp/snapshot1** returns properties of the step, a list of child datums, and a list of child steps. Child steps are indicated by a trailing forward slash.

JOBBOOT [-slot=<n>]

Sets bootup job slot *n* (RS-232 only).

JOBDELETE {[-slot=<n>]-all}

Deletes job in slot *n*, or all jobs if **-all**.

Important: Does not delete the current job loaded in camera memory.

JOBDOWNLOAD <-transfer={ymodem|ftp}> [-size=value] [-c]

Important: JOBDOWNLOAD only supports FTP on the HAWK MV-4000, as with the GETIMAGE command.

Downloads a **.avz** job file via the specified transfer method (ymodem supported only over RS-232; FTP supported only over network connection).

The **ymodem transfer method** only requires that the user send the **.avz** file via the ymodem protocol over RS-232, and the job will load automatically after the transfer is complete.

The **FTP transfer method** requires the user to perform the following steps to load the job:

- **JOBDOWNLOAD: -transfer=ftp [-size=avpsizeinbytes]**

Pre-creates a fixed-size /streamd0 RAMdisk to receive the **.avz** over FTP. If size is omitted, the default RAM disk size is used to create /streamd0. The size of /streamd0 is limited to (available contiguous RAM – minimum target contiguous RAM) / 2.

- User FTPs the job to /streamd0

- **JOBLOAD: -mem -r**

Loads **.avz** from /streamd0 into RAM, deletes the RAMDisk /streamd0, and optionally starts the job (if **-r** is specified).

JOBINFO {[-slot=<n>]} [-v]

Gets job summary or info about slot *n*.

JOBINFO with no arguments returns a list of all jobs on the device.

-v = Verbose *n*. This option shows the amount of space that would be freed if the job were deleted. It also lists the total disk space and free disk space.

JOBLOAD {[-slot=<n>|-mem} [-r]

Loads a job from slot *n* or from memory when used with the JOBDOWNLOAD command via FTP.

-r = Start inspections.

JOBSAVE [-slot=<n>

Saves current job to slot *n*.

MEMAVAIL [-cp]

Returns available memory for device or coprocessor.

MEMCONTIG [-cp]

Returns maximum memory block for device or coprocessor.

MEMFRAGS [-cp]

Returns memory fragments for device or coprocessor.

Important: MEMFRAGS is not supported by the HAWK MV-4000. It will return !ERROR.

MEMINFO [-cp] [-v]

Returns memory summary “avail/contig/frags” for device or coprocessor. Verbose.

OFFLINE

Stops all inspections.

ONLINE

Starts all inspections.

ONLINE? [-insp=*n*]

Queries if each inspection on the camera is online. Defaults to all inspections if no inspection is specified. If the camera is running in a multi-inspection job, this command will return !1 if all inspections are online and !0 otherwise.

-insp=*n* specifies the inspection to query if it is online.

QUERYAUTOCAL

Returns photometry settings: Gain, Exposure, and Focus.

QUERYFOCUSUNITS

Queries the units being used for autofocus, mm (0) or inches (1).

QUERYWHITEBAL

Returns white balance settings: RED gain, BLUE gain, and GREEN gain.

QUICKFOCUS [x] [y]

Performs an autofocus by analyzing the area around the point specified by **x** and **y**.

The response is in the format of the camera's current focus, min. allowable focus on the camera, max. allowable focus on the camera.

Example:

Perform a quick focus on point (640,480) in the image.

Command: QUICKFOCUS 640 480

Response: 124;50;300 (Current focus is set to 124 mm with an allowable focus range of 50 – 300 mm on the current camera.)

Important: This command only functions when the camera is OFFLINE.

READY? [-insp=n]

Queries if inspection is waiting for a trigger. **!1** if all inspections are ready or **!0** if not all inspections are ready.

-insp=n specifies the inspection to query if it is ready.

REBOOT [-noload]

Reboots the device.

-noload = do not load BOOT job.

RESTOREWBAL

Restores preset white balance parameters: RED gain, BLUE gain, and GREEN gain.

SET <tagname> <value>

Sets value of a global tag.

The tagname must correspond to one of the supported tags within the device. Use the **INFO** command to get a full list of tags and services, as well as attributes of the tag and list of subtags.

The value can contain spaces.

The command is terminated by a carriage return and/or line feed character.

The value can be a list of comma-separated items to set a sequence of tags:

Send **SET int1 1, 2, 3** to set int1 = 1, int2 = 2, int3 = 3.

The AVP service allows setting of step and datum information from the job tree using forward slash '/' in the symbolic name path. **SET avp/insp1/snapshot1/acq1/gain 2.0** paths are not case-sensitive and do not need to be fully qualified if unique.

SET avp/acq1/gain 2.0 will set the same gain value if there is only one acquire.

Control tags in the AVP service such as **START**, **STOP**, and **TRIGGER** act as momentary switches. **SET avp.start 1** is equivalent to the **ONLINE** command. **avp.start** will reset immediately and always read as **0**.

Success Return: On success will return **!OK** followed by an echo of the command.

For example:

```
!OK SET matchstring1
```

Fail Return: On failure will return **!ERROR** followed by the reason for the failure.

For example:

```
!ERROR Tag matchstring66 not found
```

SETFOCUSUNITS

Sets units used for autofocus, **mm (0)** or **inches (1)**.

Important: The MicroHAWK F430-F only supports mm so SETFOCUSUNITS will only accept **0** and anything else will respond with **!ERROR**.

TARGET {0|1|off|on}

Turns targeting LEDs On or Off.

target 1 = Turn Target On

target 0 = Turn Target Off

TRIGGER

Triggers an inspection.

VERSION

Returns Visionscape software version.

vt [n]

Triggers an inspection by pulsing a Virtual I/O point.

For example: **vt 1**

will return pulse **VIO1**. The inspection will run if it is configured to use **VIO 1** as a trigger.

If specified, the VIO index must be in the allowed range for Virtual I/O points within Visionscape. The virtual I/O line will be set high then low.

If VIO Index is not specified, VIO1 is assumed.

Fail Return: Return **!ERROR** followed by the reason for the failure.

For example: **!ERROR No such trigger** when the index specified 'n' is out of range of virtual triggers.

WHITEBAL

Performs automatic calibration of white balance settings: RED gain, BLUE gain, and GREEN gain.

Important: This command only functions when the camera is OFFLINE.

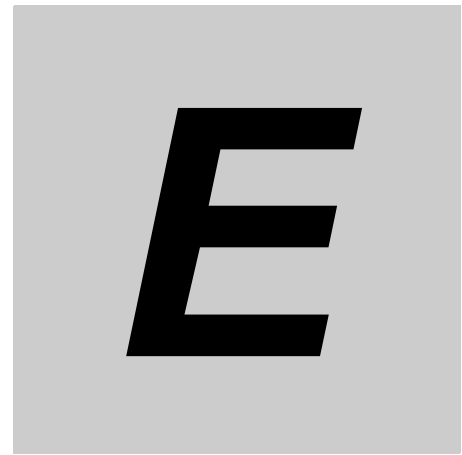

Appendix E - USB Power Management (MicroHAWK F420-F)

When your PC enters sleep mode, the USB ports may shut down and the camera may be disconnected. This section describes how to keep your PC's USB ports active if the PC enters sleep mode or other low-power modes.

E-1	USB Root Hub Power Management	E-2
------------	--	------------

E-1 USB Root Hub Power Management

Perform the following procedure to ensure that your PC does not shut down the USB connection to your MicroHAWK F420-F.

- 1 From the Windows **Start** menu, right-click on **Computer** and select **Properties**.

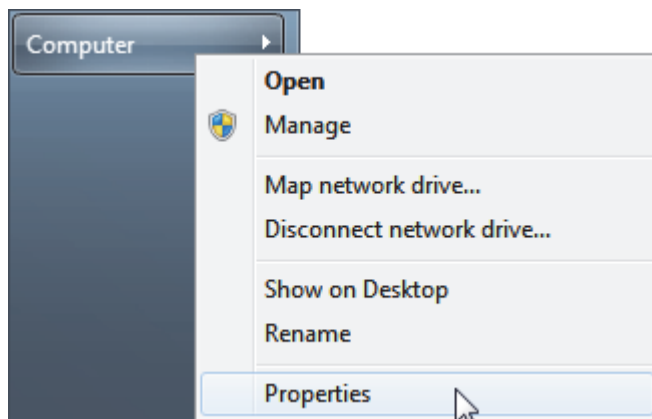

- 2 Select **Device Manager** from the options at the left side of the screen.

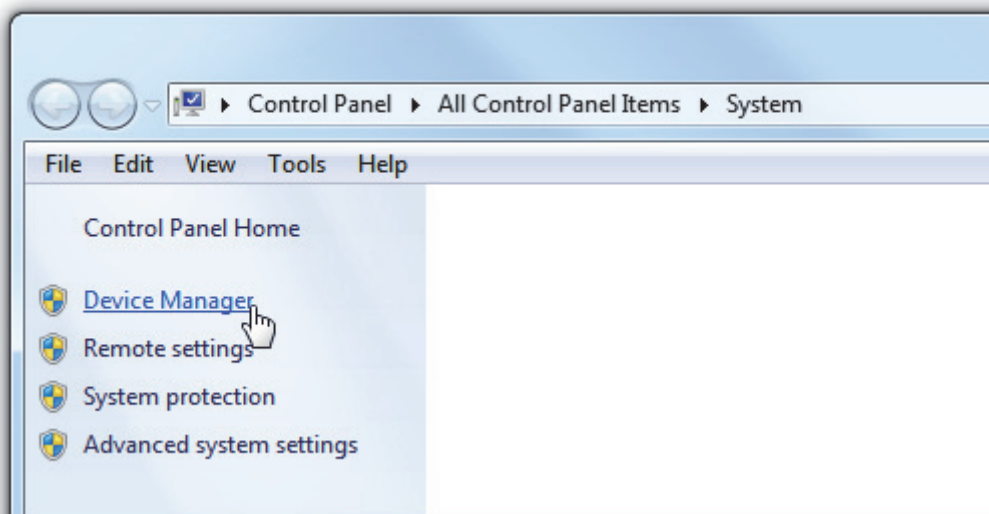

- 3 In the Device Manager, locate and expand the **Universal Serial Bus controllers** item. Right-click on **USB Root Hub** and select **Properties**.

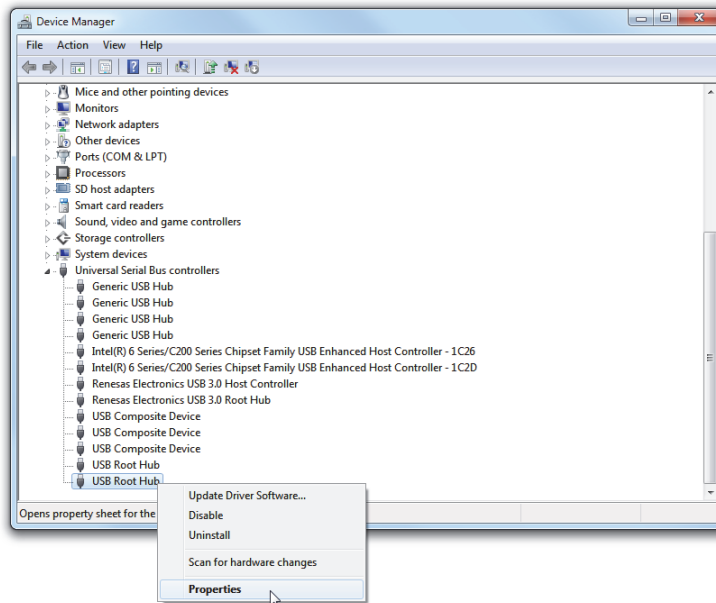

- 4 In the **USB Root Hub Properties** dialog, select the **Power Management** tab. Un-check the box next to **Allow the computer to turn off this device to save power**. Repeat steps 3 and 4 for each **USB Root Hub** item in the **Universal Serial Bus controllers** list.

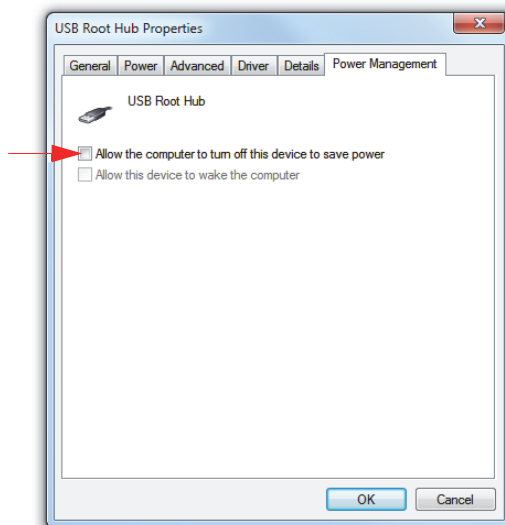



Appendix F - TCP/UDP and General Port Usage

This section lists the ports used by smart cameras for communication.

F-1	Ports.....	F-2
-----	------------	-----

F-1 Ports

The following table lists the ports used by MicroHAWK F-Series Smart Cameras for communication.

Name	Protocol	Port Number
RPC	TCP	49059
I/O	TCP	49049
PIC/LIVE	TCP	49050
REPORT	TCP	49200
REPORTCONTROL	TCP	49202
PARTQ	TCP	49201
KEEPALIVE	TCP	49079
Serial TCP#1	TCP	49211
Serial TCP#2	TCP	49212
Serial TCP#3	TCP	49213
Serial TCP#4	TCP	49214
UDP BROADCAST	UDP	49497
UDP COMMAND	UDP	49496
FTP	TCP	21
TELNET	TCP	23
HTTP (Web Server Port) When Running on PC	HTTP	8080
HTTP (Web Server Port) When Running Smart Camera	HTTP	80
HAWK MV-4000 Monitor Process	HTTP	8088
HAWK MV-4000 Web Server Port	HTTP	8081
EIP Explicit Messaging	TCP	44818
EIP Implicit Messaging	UDP	2222
PROFINET	UDP	34964



Appendix G - Optics and Lighting Accessory Kit Installation



This section contains instructions for how to install optical accessories on a MicroHAWK F320-F, F330-F, F420-F and F430-F.

G-1 Optics and Lighting Accessories.	G-2
---	------------

G-1 Optics and Lighting Accessories

MicroHAWK Optics and Lighting Accessory List

This section contains instructions for how to install the optical accessories on a MicroHAWK ID/MV-20, V/F320-F, V/F330-F, V/F420-F and V/F430-F.

Contents

1. MicroHAWK ID/MV-20 Diffuser and Polarizer Kit Installation
2. MicroHAWK V/F3XX-F Diffuser and Polarizer Kit Installation
3. MicroHAWK V/F4XX-F Window and LED Kit Installation
4. MicroHAWK V/F4XX-F With Ring Light Window and LED Kit Installation
5. MicroHAWK V/F4XX-F Polarizer Kit Installation

Type	Description	Kit Part Number
ID/MV-20 Window Kits	Kit, Diffuser, MicroHAWK ID/MV-20	98-9000077-01
	Kit, Polarizer, MicroHAWK ID/MV-20	98-9000062-01
V/F330-F and V/F320-F Window Kits	Kit, Diffuser, MicroHAWK V/F330	V330-AF1
	Kit, Polarizer, MicroHAWK V/F330	V330-AF2
V/F430-F and V/F420-F Window Kits	Kit, Window, V/F4XX	V430-AF10*
	Kit, Diffuser, V/F4XX	V430-AF11*
	Kit, Polarizer, V/F4XX	V430-AF12*
	Kit, YAG Filter, V/F4XX	V430-AF4
	Kit, ESD Window, V/F4XX	V430-AF5
	Kit, Red Filter, V/F4XX	V430-AF6
	Kit, Blue Filter, V/F4XX	V430-AF7
V/F430-F and V/F420-F LED Kits	Kit, Red LED, V/F4XX	V430-ALR
	Kit, White LED, V/F4XX	V430-ALW
	Kit, Blue LED, V/F4XX	V430-ALB
	Kit, IR LED, V/F4XX	V430-ALI
V/F430-F With Ring Light Window Kits	Kit, Window, RING LT, F/V430	V430-AF0R
	Kit, Diffuser, RING LT, F/V430	V430-AF1R
	Kit, Polarizer, RING LT, F/V430	V430-AF2R
V/F430-F With Ring Light LED Kits	Kit, Red LED, RING LT, F/V430	V430-ALRR
	Kit, White LED, RING LT, F/V430	V430-ALWR
	Kit, Blue LED, RING LT, F/V430	V430-ALBR
	Kit, IR LED, RING LT, F/V430	V430-ALIR

* Note: V430-AF10, AF11, and AF12 are used for MicroHAWK V/F4X0-FXXXXXXX-XXX cameras in this datasheet. The prior generation MicroHAWK V430-FXXXXXXX code reader uses part numbers V430-AF0, AF1, and AF2. Please select the correct accessory from the table based on your camera part number format.

Accessory	Prior V430-FXXXXXXX Code Reader	New V/F4X0-FXXXXXXX-XXX Code Reader and Smart Camera
Front Window Installation Kit	V430-AF0	V430-AF10
Diffuser Installation Kit	V430-AF1	V430-AF11
Polarizer Installation Kit	V430-AF2	V430-AF12

MicroHAWK ID/MV-20 Diffuser and Polarizer Kit Installation

Diffuser Kit Hardware, MicroHAWK ID/MV-20

Qty	Description	Kit Part Number
1	Kit, Diffuser, MicroHAWK ID/MV-20	98-9000077-01

Diffuser Kit Installation, MicroHAWK ID-20/MV-20

Step 1: Peel the protective liner from the adhesive on the diffuser.

Step 2: Rest the narrow edge of the diffuser on the bottom edge of the window opening at an angle as shown below.

Step 3: Center the diffuser left-to-right in the window opening.

Step 4: Affix the diffuser to the window.

Step 5: Run your finger over the surface of the diffuser using light pressure to complete the bond.

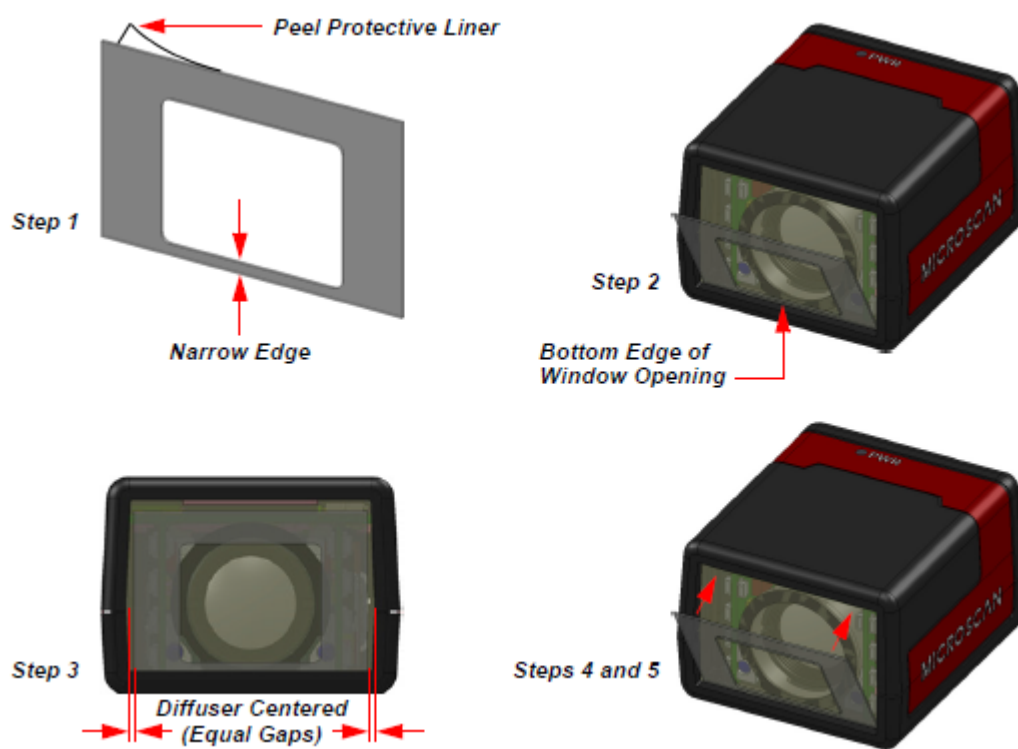

Polarizer Kit Hardware, MicroHAWK ID-20/MV-20

Qty	Description	Kit Part Number
1	Kit, Polarizer, MicroHAWK ID/MV-20	98-9000062-01

Polarizer Kit Installation, MicroHAWK ID-20/MV-20

Step 1: Peel the protective liner from adhesive on the polarizer.

Step 2: Rest the narrow edge of the polarizer on the bottom edge of the window opening at an angle as shown below.

Step 3: Center the polarizer left-to-right in the window opening.

Step 4: Affix the polarizer to the window.

Step 5: Run your finger over the surface of the polarizer using light pressure to complete the bond.

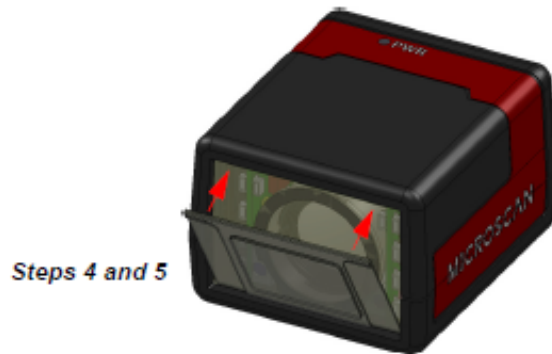
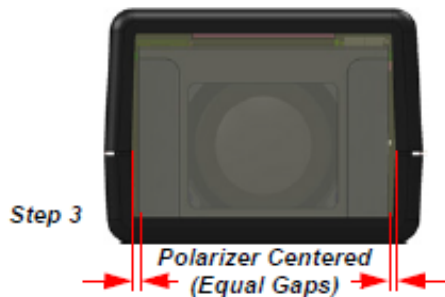
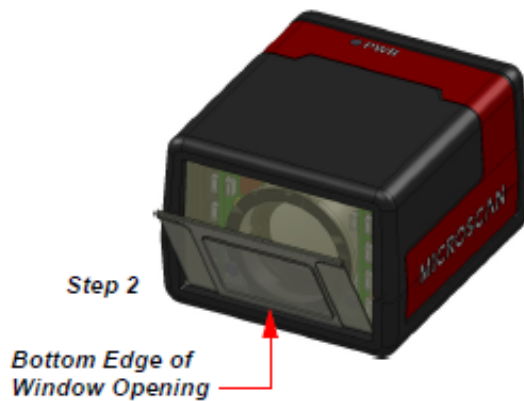
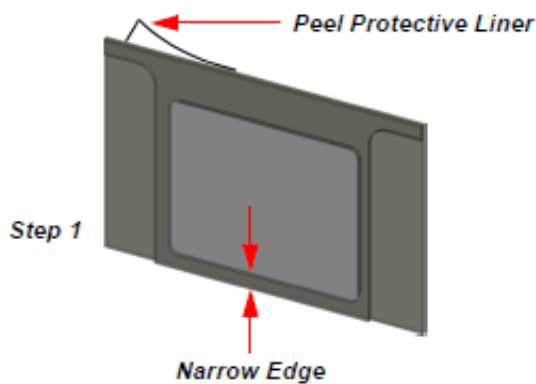

MicroHAWK V/F3XX-F Diffuser and Polarizer Kit Installation

Qty	Description	Kit Part Number
1	Kit, Diffuser, MicroHAWK ID/MV-20	V330-AF1

Diffuser Kit Installation, MicroHAWK V/F330 and V/F320

Step 1: Follow same steps as above for the ID/MV-20

Note: Take care to align the Diffuser so that the narrow edge is at bottom, that there is an equal gap laterally, and that the bottom edge is aligned with bottom edge of window.



Polarizer Kit Hardware, MicroHAWK V/F330-F and V/F320-F

Qty	Description	Kit Part Number
1	Kit, Polarizer, MicroHAWK V/F330	V330-AF2

Polarizer Kit Installation, MicroHAWK V/F330 and V/F320

Step 1: Follow same steps as above for the ID/MV-20

Note: Take care to align the Polarizer so that the narrow edge is at bottom, that there is an equal gap laterally, and that the bottom edge is aligned with bottom edge of window.



MicroHAWK V/F4XX-F Window and LED Kit Installation

Window Kit Hardware, MicroHAWK V/F430-F and V/F420-F

Qty	Description	Kit Part Number
1	Window, Diffuser, Polarizer or Filter Kits (included)	V430-AF10 (Window) V430-AF11 (Diffuser) V430-AF12 (Polarizer) V430-AF4 (YAG Filter) V430-AF5 (ESD Window) V430-AF6 (Red Filter) V430-AF7 (Blue Filter)
4	0-80 Phillips-Head Screws (included)	
1	Gasket (included)	
1	Phillips Torque Wrench (not included)	N/A

LED Kit Hardware, MicroHAWK V/F430-F and V/F420-F

Qty	Description	Kit Part Number
1	LED Board Kits (included)	V430-ALR (Red LEDs) V430-ALW (White LEDs) V430-ALB (Blue LEDs) V430-ALI (IR LEDs)
4	0-80 Phillips-Head Screws (included)	
1	Gasket (included)	
1	Phillips Torque Wrench (not included)	N/A
1	Fine-Tip Tweezers (not included)	N/A

Window Removal, MicroHAWK V/F4XX-F

Step 1: Disconnect power from the camera.

Step 2: Remove the four screws from the front window of the camera.

Step 3: Remove the front window and gasket.

Note: If installing a window accessory only, skip to **Step 8**.

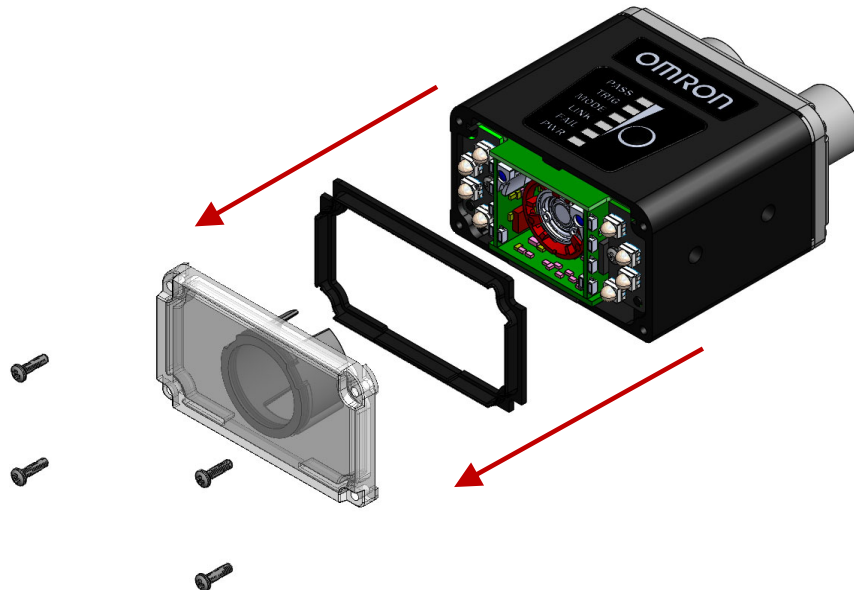

Outer LED Removal, MicroHAWK V/F4XX-F

Note: If installing an LED accessory only, skip to **Step 6**.

Step 4: Remove the two screws from the LED boards.

Step 5: Unplug the LED boards from the camera.

Note: The LED boards have a connector interface. Gently pry the top of each LED board from the main board using fine-tipped tweezers or an equivalent tool. Use caution not to contact the LEDs as they may become damaged.

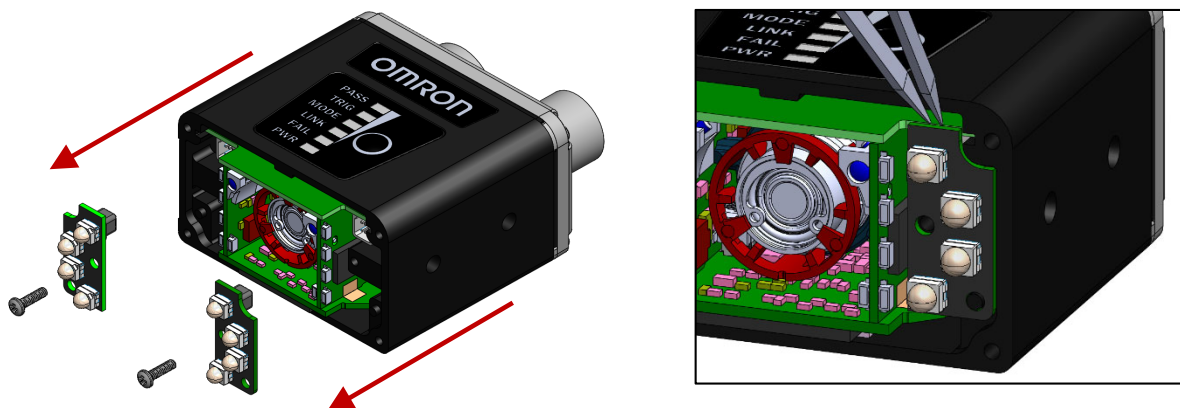

Outer LED Installation, MicroHAWK V/F4XX-F

Step 6: Plug the LED boards into the main board. Use caution not to touch the LEDs, as they may be damaged by contact.

Step 7: Secure the LED boards in place using the screws provided. Do not over-tighten the screws.

(1.0 in./lbs. (0.11 nm max.))

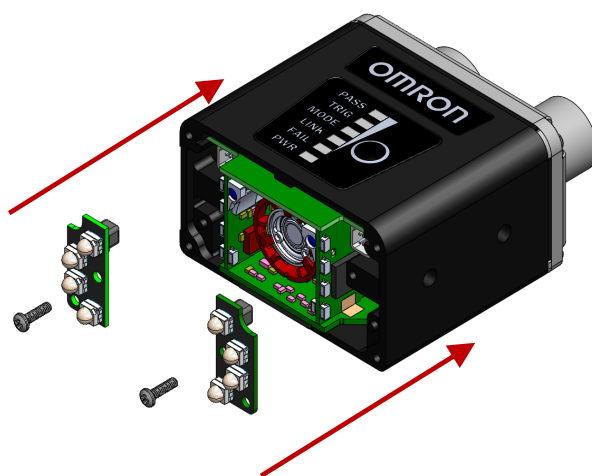

Window Installation, MicroHAWK V/F4XX-F

Step 8: Install the gasket onto the camera. Ensure that the gasket is properly seated in place and is covering all sealing surfaces.

Step 9: Install the window (or window accessory) onto the camera.

Step 10: Secure the window in place using the screws provided. Do not over-tighten the screws.
(1.0 in./lbs. (0.11 nm max.)

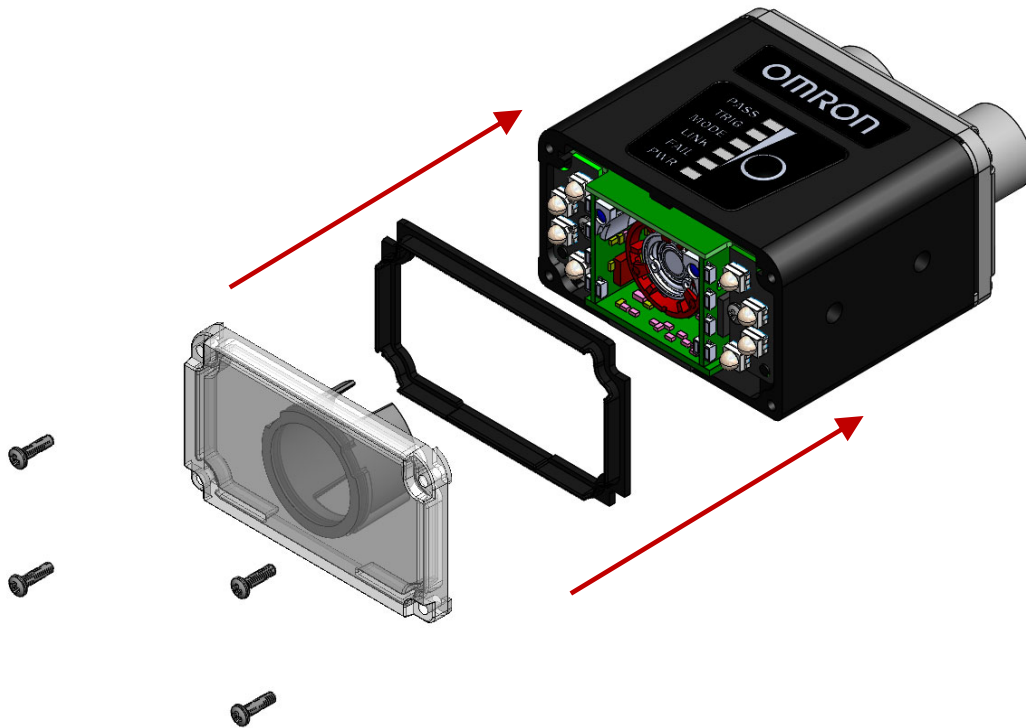

MicroHAWK V/F430-F with Ring Light Window and LED Installation

Window Kit Hardware, MicroHAWK V/F430-F with Ring Light

Qty	Description	Part Number
1	Window Assembly (included)	V430-AF0R (Window) V430-AF1R (Diffuser)
1	Window Gasket (included)	
2	#2-56 X 3/8" Phillips Flat Head Screw (included)	
4	#4-40 X 1/4" Phillips Pan Head Screw w/ Lock Washers (included)	
1	Phillips Torque Wrench (not included)	N/A

LED Kit Hardware, MicroHAWK V/F430-F with Ring Light

Qty	Description	Part Number
1	LED Board Kits (included)	V430-ALR (Red LEDs) V430-ALW (White LEDs) V430-ALB (Blue LEDs) V430-ALI (IR LEDs)
1	Window Gasket (included)	
2	#2-56 X 3/8" Phillips Flat Head Screw (included)	
4	#4-40 X 1/4" Phillips Pan Head Screw w/ Lock Washers (included)	
1	Phillips Torque Wrench (not included)	N/A

Window Removal, MicroHAWK V/F430-F with Ring Light

Step 1: Disconnect power from the camera.

Step 2: Unscrew the four #4-40 pan head screws that secure the window.

Step 3: Remove the gasket from around the window frame.

Step 4: If not replacing the LED Board, go to step 8. If replacing the LED Board, unscrew the two #2-56 flat head screws that secure the diffuser.

Note: Do not touch the electronics or lens, as this may cause damage.

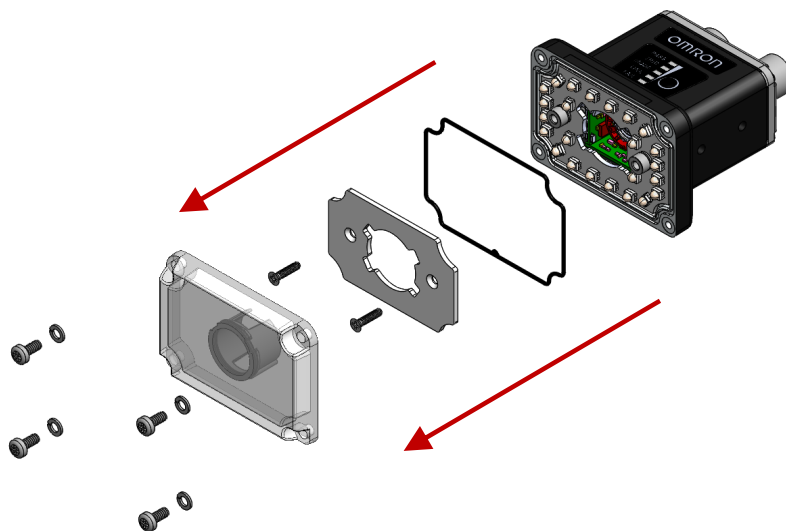

Outer LED Removal, MicroHAWK V/F430-F Ring Light

Step 5: Unplug the LED board from the camera.

Note: The LED board has two connectors on the left and right of the camera front face. Gently pry the LED board from the camera using fine-tipped tweezers or an equivalent tool. Use caution not to contact the LEDs as they may become damaged.

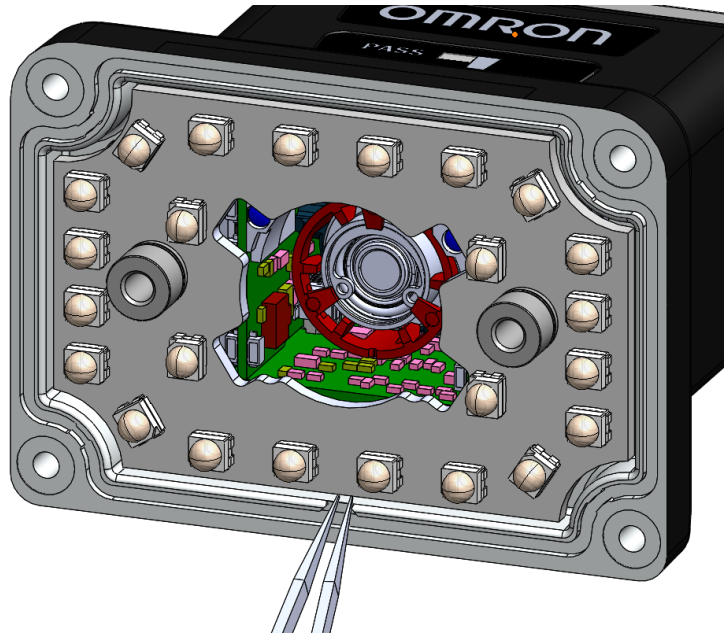

Outer LED Installation, MicroHAWK V/F430-F with Ring Light

Step 6: Plug the new LED board into the camera connectors. Use caution not to touch the LEDs, as they may be damaged by contact.

Window Installation, MicroHAWK V/F430-F with Ring Light

Step 7: Reinstall the new #2-56 flat head screws through the diffuser into the camera PEM nuts. Do not overtighten the screws (1.9 in-lbs. (0.21 Nm) max)

Step 8: Install the new gasket, ensuring that it is fully constrained within the gasket groove.

Step 9: Place the window on the front of the unit and secure with the new #4-40 pan head screws and lock washers. Do not overtighten the screws (2.9 in-lbs. (0.33 Nm) max).

Step 10: Inspect the gasket to ensure it did not come out of the groove in the window frame.

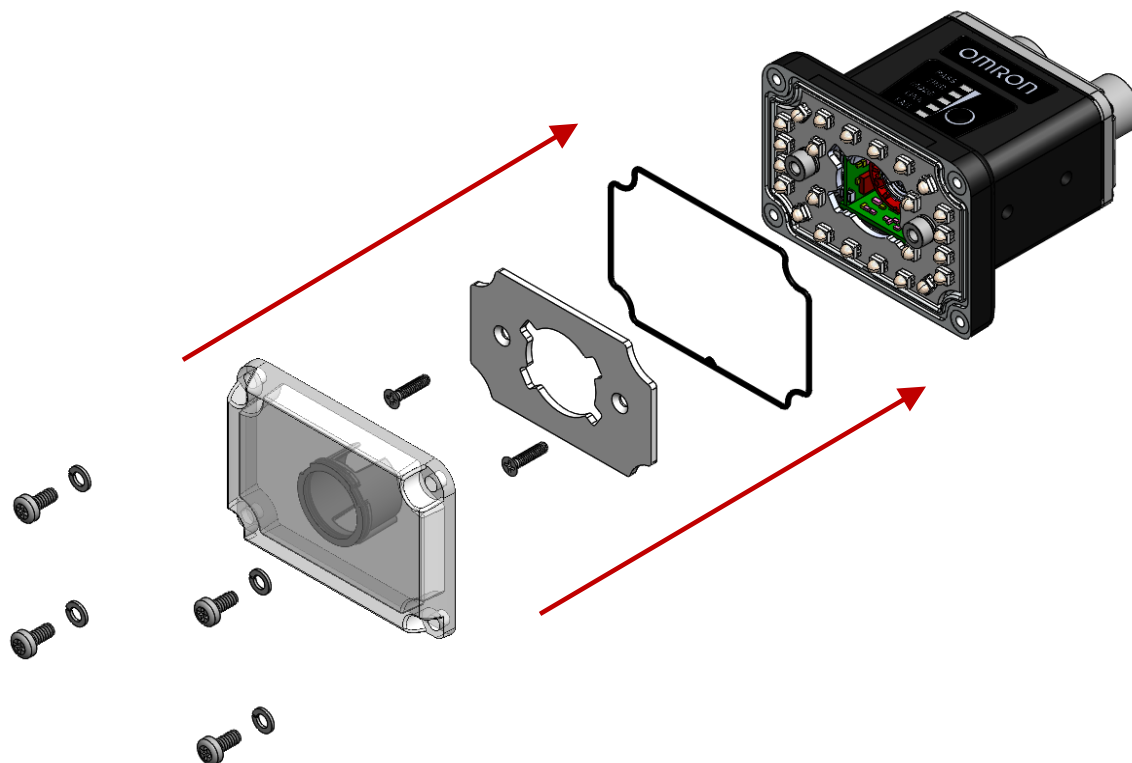

MicroHAWK V/F430-F with Ring Light Polarizer Kit Installation

Polarizer Kit Hardware, MicroHAWK V/F430-F with Ring Light

Qty	Description	Kit Part Number
1	Window Assembly (included)	V430-AF2R (Polarizer)
1	Window Gasket (included)	
2	#2-56 X 3/8" Phillips Flat Head Screw (included)	
4	#4-40 X 1/4" Phillips Pan Head Screw w/ Lock Washers (included)	
1	Phillips Torque Wrench (not included)	N/A

Window Removal, MicroHAWK V/F430-F with Ring Light

Step 1: Disconnect power from the camera.

Step 2: Unscrew the four #4-40 pan head screws that secure the window.

Step 3: Remove the gasket from around the window frame.

Step 4: Remove the two #2-56 flat head screws. Remove and dispose of the diffuser.

Note: Do not touch the electronics or lens, as this may cause damage.

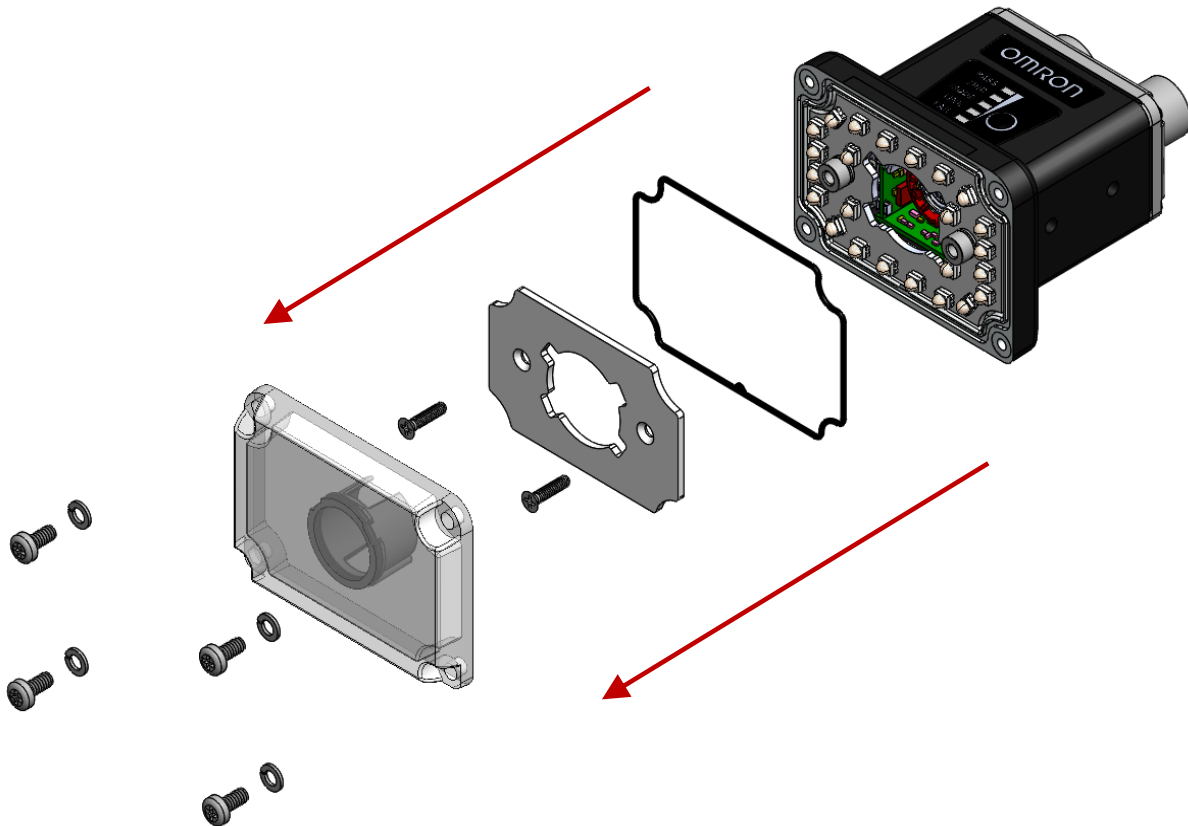

Polarizer Window Installation, MicroHAWK V/F430-F with Ring Light

Step 5: Reinstall the new #2-56 flat head screws in the LED board PEM nuts without replacing the diffuser. Do not overtighten the screws (1.9 in-lbs. (0.21 Nm) max)

Step 6: Install the new gasket, ensuring that it is fully constrained within the gasket groove.

Step 7: Place the polarizer window on the front of the unit and secure with the new #4-40 pan head screws and lock washers. Do not overtighten the screws (2.9 in-lbs. (0.33 Nm) max).

Step 8: Inspect the gasket to ensure it did not come out of the groove in the window frame.

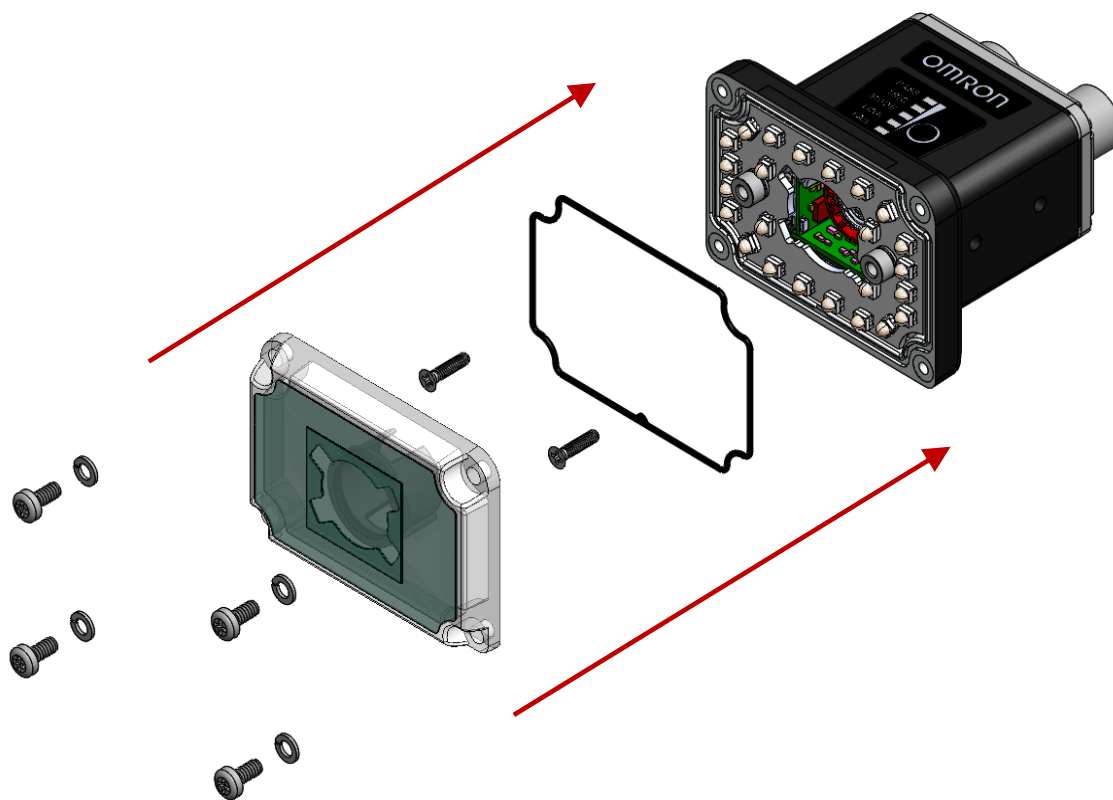

OMRON AUTOMATION AMERICAS HEADQUARTERS • Chicago, IL USA • 847.843.7900 • 800.556.6766 • automation.omron.com

OMRON CANADA, INC. • HEAD OFFICE

Toronto, ON, Canada • 416.286.6465 • 866.986.6766 • automation.omron.com

OMRON ELECTRONICS DE MEXICO • HEAD OFFICE

Ciudad de México • 52.55.5901.4300 • 01.800.386.6766 • mela@omron.com

OMRON ELECTRONICS DE MEXICO • SALES OFFICE

San Pedro Garza García, N.L. • 81.12.53.7392 • 01.800.386.6766 • mela@omron.com

OMRON ELECTRONICS DE MEXICO • SALES OFFICE

Eugenio Garza Sada, León, Gto • 01.800.386.6766 • mela@omron.com

OMRON ELETRÔNICA DO BRASIL LTDA • HEAD OFFICE

São Paulo, SP, Brasil • 55 11 5171-8920 • automation.omron.com

OMRON ARGENTINA • SALES OFFICE

Buenos Aires, Argentina • +54.11.4521.8630 • +54.11.4523.8483
mela@omron.com

OTHER OMRON LATIN AMERICA SALES

+54.11.4521.8630 • +54.11.4523.8483 • mela@omron.com

Authorized Distributor:

Controllers & I/O

- Machine Automation Controllers (MAC) • Motion Controllers
- Programmable Logic Controllers (PLC) • Temperature Controllers • Remote I/O

Robotics

- Industrial Robots • Mobile Robots

Operator Interfaces

- Human Machine Interface (HMI)

Motion & Drives

- Machine Automation Controllers (MAC) • Motion Controllers • Servo Systems
- Frequency Inverters

Vision, Measurement & Identification

- Vision Sensors & Systems • Measurement Sensors • Auto Identification Systems

Sensing

- Photoelectric Sensors • Fiber-Optic Sensors • Proximity Sensors
- Rotary Encoders • Ultrasonic Sensors

Safety

- Safety Light Curtains • Safety Laser Scanners • Programmable Safety Systems
- Safety Mats and Edges • Safety Door Switches • Emergency Stop Devices
- Safety Switches & Operator Controls • Safety Monitoring/Force-guided Relays

Control Components

- Power Supplies • Timers • Counters • Programmable Relays
- Digital Panel Meters • Monitoring Products

Switches & Relays

- Limit Switches • Pushbutton Switches • Electromechanical Relays
- Solid State Relays

Software

- Programming & Configuration • Runtime